

# LM380 Audio Power Amplifier

## General Description

The LM380 is a power audio amplifier for consumer application. In order to hold system cost to a minimum, gain is internally fixed at 34 dB. A unique input stage allows inputs to be ground referenced. The output is automatically self centering to one half the supply voltage.

The output is short circuit proof with internal thermal limiting. The package outline is standard dual-in-line. A copper lead frame is used with the center three pins on either side comprising a heat sink. This makes the device easy to use in standard p-c layout.

Uses include simple phonograph amplifiers, intercoms, line drivers, teaching machine outputs, alarms, ultrasonic drivers, TV sound systems, AM-FM radio, small servo drivers, power converters, etc.

A selected part for more power on higher supply voltages is available as the LM384. For more information see AN-69.

## Features

- Wide supply voltage range
- Low quiescent power drain
- Voltage gain fixed at 50
- High peak current capability
- Input referenced to GND
- High input impedance
- Low distortion
- Quiescent output voltage is at one-half of the supply voltage
- Standard dual-in-line package

## Connection Diagrams (Dual-In-Line Packages, Top View)

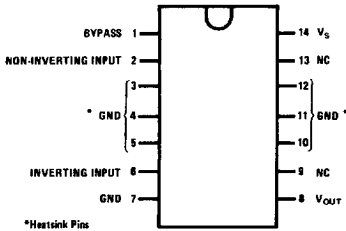

TL/H/6977-1

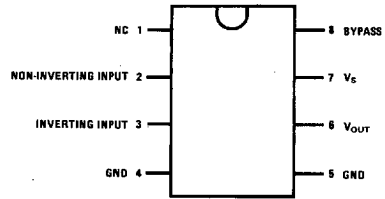

TL/H/6977-2

Order Number LM380N  
See NS Package Number N14A

Order Number LM380N-8  
See NS Package Number N08E

## Block and Schematic Diagrams

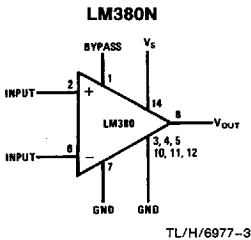

TL/H/6977-3

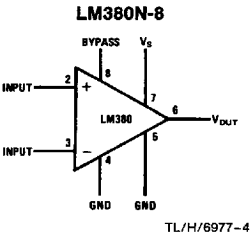

TL/H/6977-4

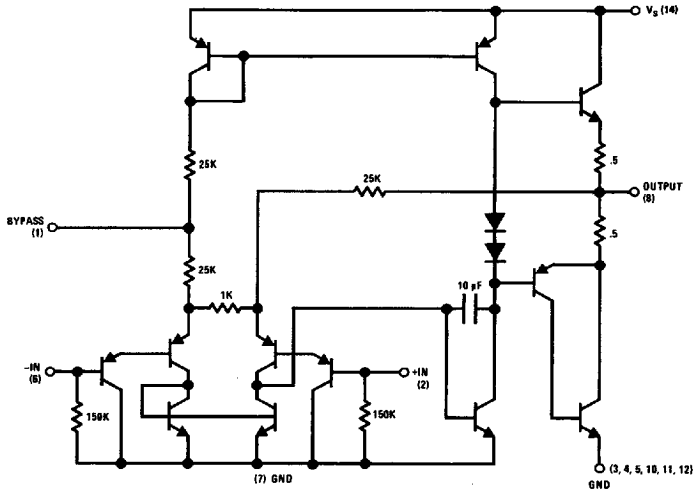

TL/H/6977-5

## Absolute Maximum Ratings

If Military/Aerospace specified devices are required, please contact the National Semiconductor Sales Office/Distributors for availability and specifications.

Supply Voltage	22V
Peak Current	1.3A
Package Dissipation 14-Pin DIP (Notes 6 and 7)	8.3W
Package Dissipation 8-Pin DIP (Notes 6 and 7)	1.67W
Input Voltage	±0.5V
Storage Temperature	-65°C to +150°C

Operating Temperature	0°C to +70°C
Junction Temperature	+150°C
Lead Temperature (Soldering, 10 sec.)	+260°C
ESD rating to be determined	
Thermal Resistance	
$\theta_{JC}$ (14-Pin DIP)	30°C/W
$\theta_{JC}$ (8-Pin DIP)	37°C/W
$\theta_{JA}$ (14-Pin DIP)	79°C/W
$\theta_{JA}$ (8-Pin DIP)	107°C/W

## Electrical Characteristics (Note 1)

Symbol	Parameter	Conditions	Min	Typ	Max	Units
$P_{OUT(RMS)}$	Output Power	$R_L = 8\Omega$ , THD = 3% (Notes 3, 4)	2.5			W
$A_v$	Gain		40	50	60	V/V
$V_{OUT}$	Output Voltage Swing	$R_L = 8\Omega$		14		$V_{p-p}$
$Z_{IN}$	Input Resistance			150k		$\Omega$
THD	Total Harmonic Distortion	(Notes 4, 5)		0.2		%
PSRR	Power Supply Rejection Ratio	(Note 2)		38		dB
$V_S$	Supply Voltage		10		22	V
BW	Bandwidth	$P_{OUT} = 2W$ , $R_L = 8\Omega$		100k		Hz
$I_Q$	Quiescent Supply Current			7	25	mA
$V_{OUTQ}$	Quiescent Output Voltage		8	9.0	10	V
$I_{BIAS}$	Bias Current	Inputs Floating		100		nA
$I_{SC}$	Short Circuit Current			1.3		A

Note 1:  $V_S = 18V$  and  $T_A = 25^\circ C$  unless otherwise specified.

Note 2: Rejection ratio referred to the output with  $C_{BYPASS} = 5 \mu F$ .

Note 3: With device Pins 3, 4, 5, 10, 11, 12 soldered into a  $\frac{1}{16}$ " epoxy glass board with 2 ounce copper foil with a minimum surface of 6 square inches.

Note 4:  $C_{BYPASS} = 0.47 \mu F$  on Pin 1.

Note 5: The maximum junction temperature of the LM380 is  $150^\circ C$ .

Note 6: The package is to be derated at  $15^\circ C/W$  junction to heat sink pins for 14-pin pkg;  $75^\circ C/W$  for 8-pin.

## Heat Sink Dimensions

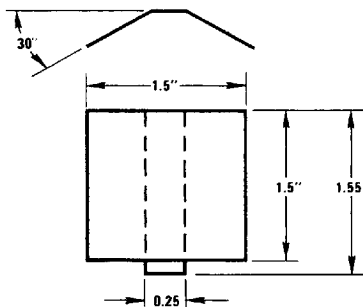

Staver Heat Sink #V-7  
 Staver Company  
 41 Saxon Ave.  
 P.O. Drawer H  
 Bayshore, NY 11706  
 Tel: (516) 666-8000  
 Copper Wings  
 2 Required  
 Soldered to  
 Pins 3, 4, 5,  
 10, 11, 12  
 Thickness 0.04  
 Inches

TL/H/6977-6

# Typical Performance Characteristics

**Maximum Device Dissipation vs Ambient Temperature**

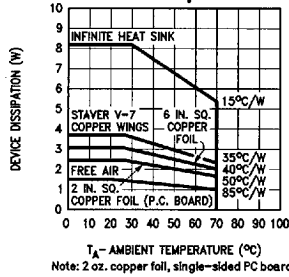

TL/H/6977-12

**Device Dissipation vs Output Power—4 $\Omega$  Load**

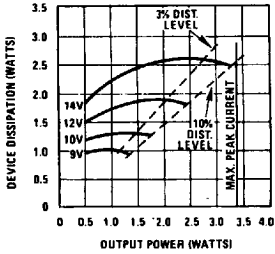

**Device Dissipation vs Output Power—8 $\Omega$  Load**

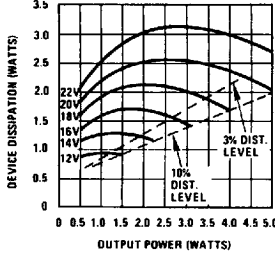

**Device Dissipation vs Output Power—16 $\Omega$  Load**

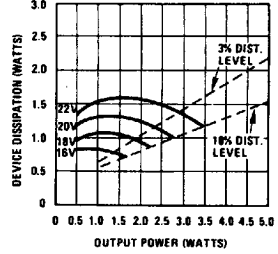

**Power Supply Current vs Supply Voltage**

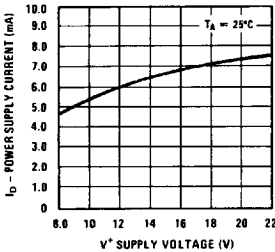

**Total Harmonic Distortion vs Frequency**

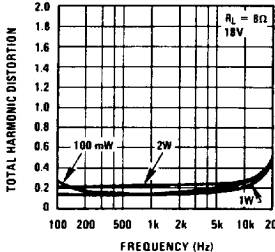

**Output Voltage Gain and Phase vs Frequency**

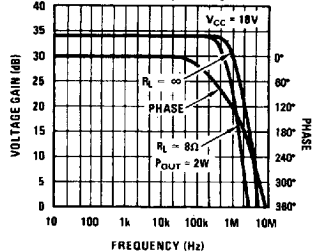

**Total Harmonic Distortion vs Output Power**

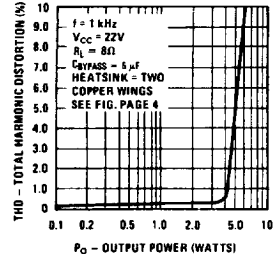

**Device Dissipation vs Output Power**

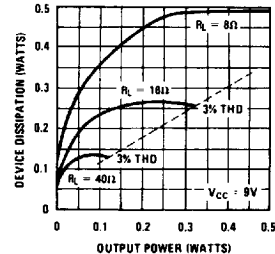

**Supply Decoupling vs Frequency**

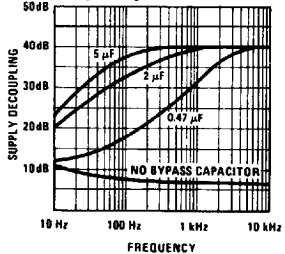

TL/H/6977-7

# Typical Applications

## Phono Amplifier

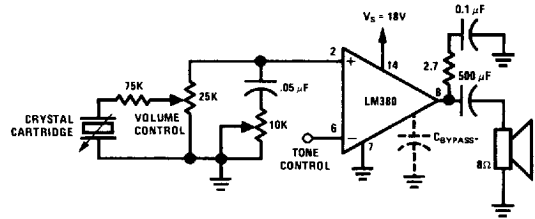

TL/H/6977-8

## Bridge Amplifier

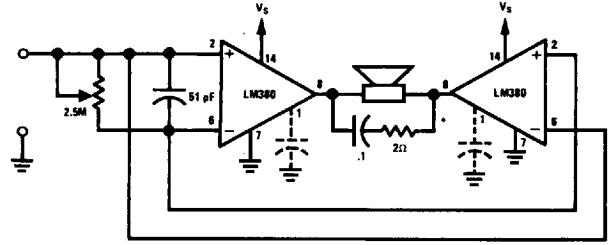

TL/H/6977-9

## Intercom

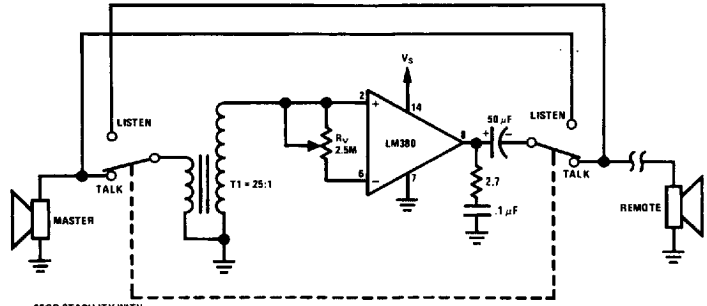

\*FOR STABILITY WITH HIGH CURRENT LOADS

TL/H/6977-10

## Phase Shift Oscillator

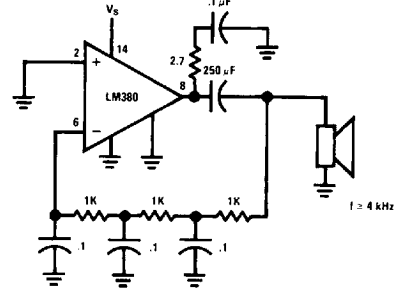

TL/H/6977-11