

X. WIRING AND SCHEMATIC DIAGRAMS, PARTS LISTS

SOUND BOARD ASSY. (A6), COMPONENT LOCATION

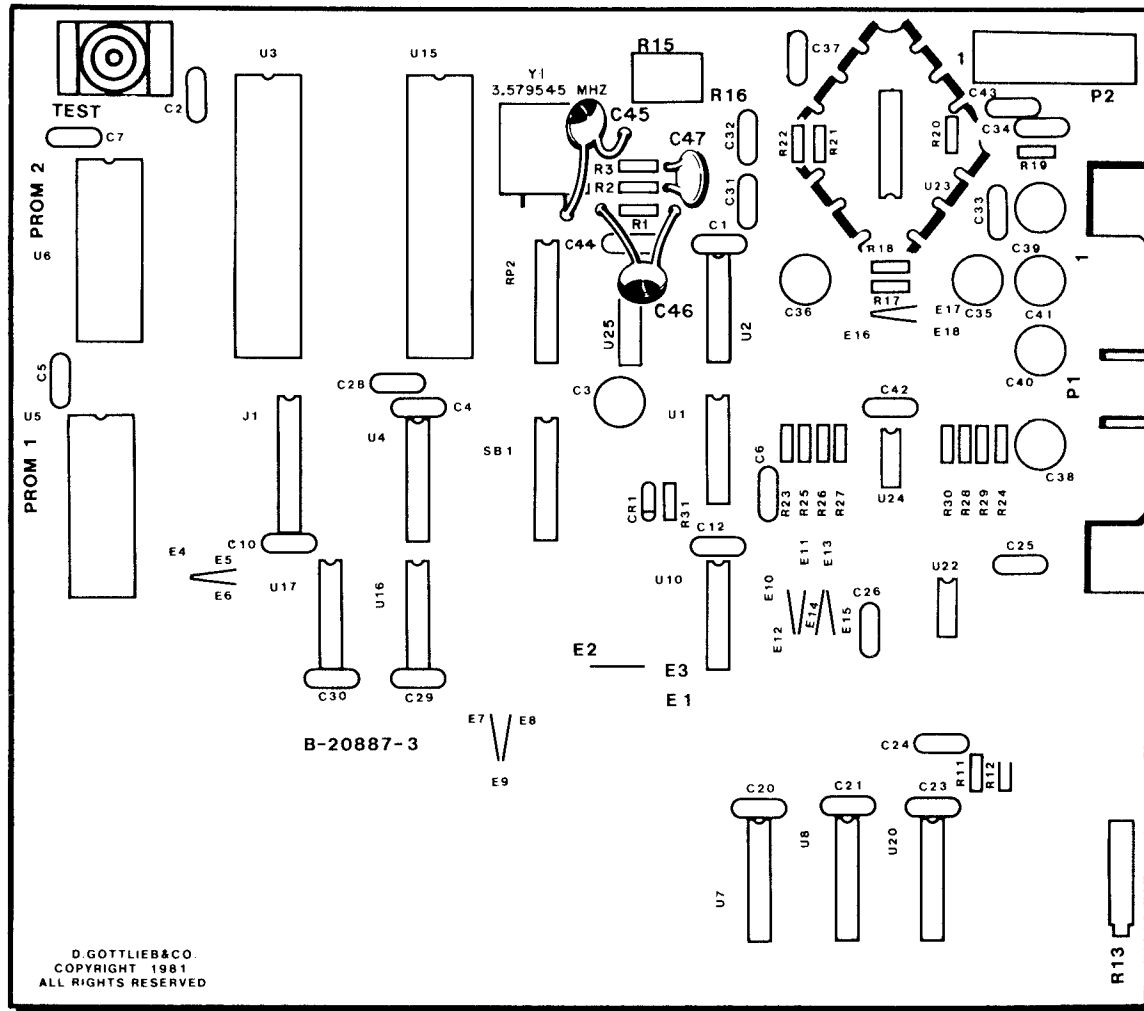

D. GOTTLIEB & CO.
COPYRIGHT 1981
ALL RIGHTS RESERVED

SOUND BOARD ASSY. (A6), PARTS LIST

REFERENCE	DESCRIPTION	PART NUMBER
	Sound Board Assembly	MA-309
C1, C2	Capacitor, 0.1UF, 25V	XO-248
C4-C7, C10		
C12, C20, C21		
C23, C25, C26		
C28, C29, C30		
C33, C42, C44		
C31, C32	Capacitor, .047UF, 25V	XO-222
C37	Capacitor, 4.7UF, 35V	XO-291
C3, C38-C41	Capacitor, 47UF, 50V	XO-210
C24	Capacitor, 100PF	XO-223
C36	Capacitor, 470UF, 35V	XO-284
C45, C46	Capacitor, 33PF	XO-277
C47	Capacitor, .01UF, 100V	XO-202
CR1	Diode, 1N4148	XO-261
R1, R11, R12	Resistor, 5.6K ohm, 5%, 1/4W	XO-19
R2, R3	Resistor, 2K ohm, 5%, 1/4W	XO-14
R13	Potentiometer, 10K ohm	XO-108
R23-R30	Resistor, 10K ohm, 5%, 1/4W	XO-18
R15	Potentiometer, 10K ohm	XO-109
R18, R21	Resistor, 100K ohm, 5%, 1/4W	XO-45
R22	Resistor, 2K ohm, 5%, 1/4W	XO-14
R31	Resistor, 68K ohm, 5%, 1/4W	XO-189
RP2	Resistor, DIP	XO-168
SB1	Switch, DIP	XO-505
SW1	Switch, Momentary Pushbutton	XO-515
U1	IC, 7414	XO-397
U2	IC, SN74LS74N	XO-434
U3	CPU, R6502-13	XO-360
U4	IC, SN74LS138N	XO-437
U5, U6	EPROM, 2716	PR-53
U7	IC, SN74LS75	XO-394
U10	IC, SN74LS02N	XO-428
U15	RR10T, R6532-18	XO-361
U16	IC, SN74LS04N	XO-418
U17	IC, SN74LS30N	XO-432
U20	Converter, PMI, 1408A-6P	XO-416
U22	IC, LM741CP	XO-393
U23	IC, LM379S	XO-395
U24	IC, Dual Comparator, LM193	XO-396
U25	Inverter, 7404	XO-402
Y1	Crystal, 3.579545MHZ	XO-456
	Socket, 22 Pin DIP	XO-467
	Socket, 24 Pin (2)	XO-529
	Socket, 40 Pin (2)	XO-530

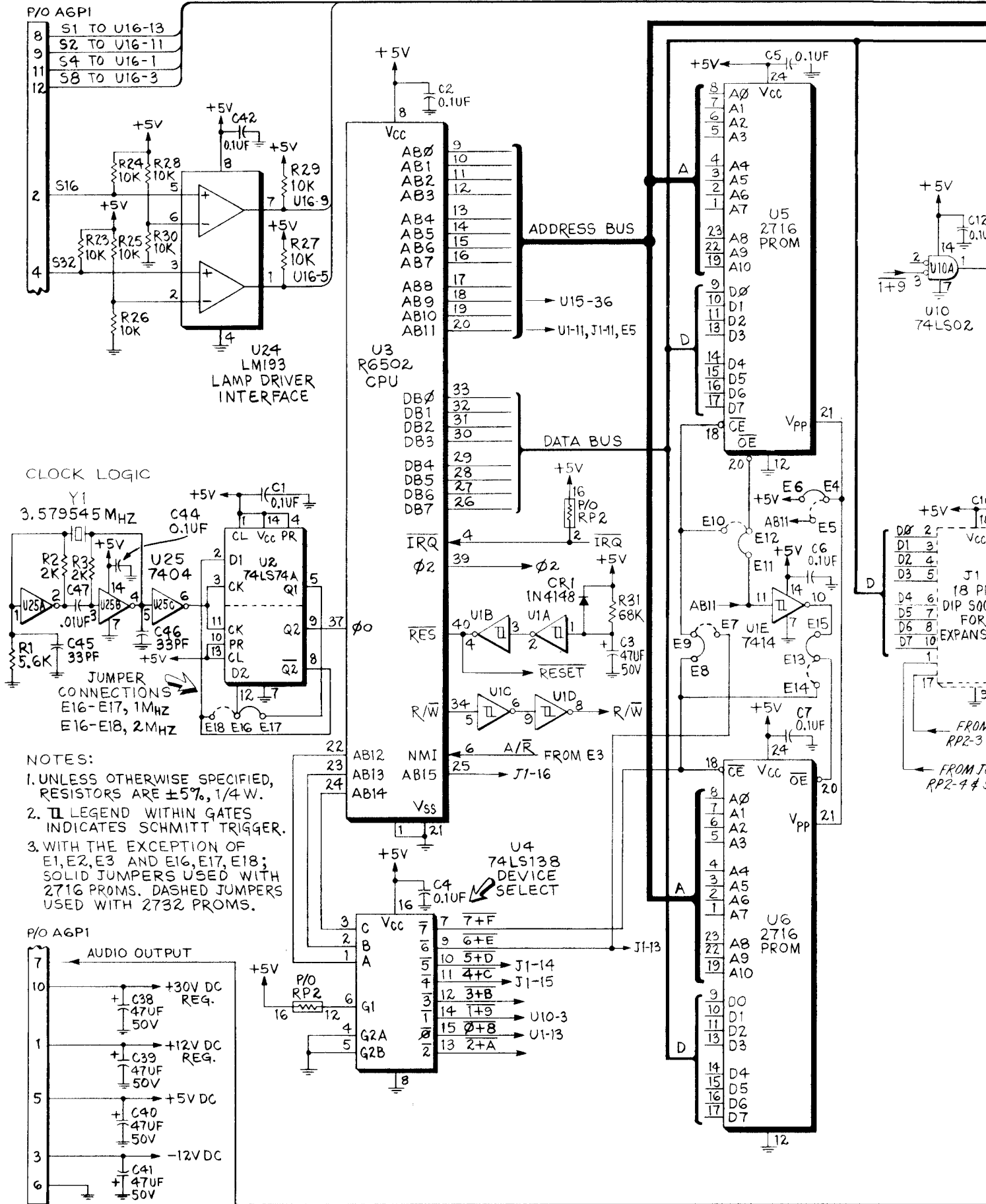

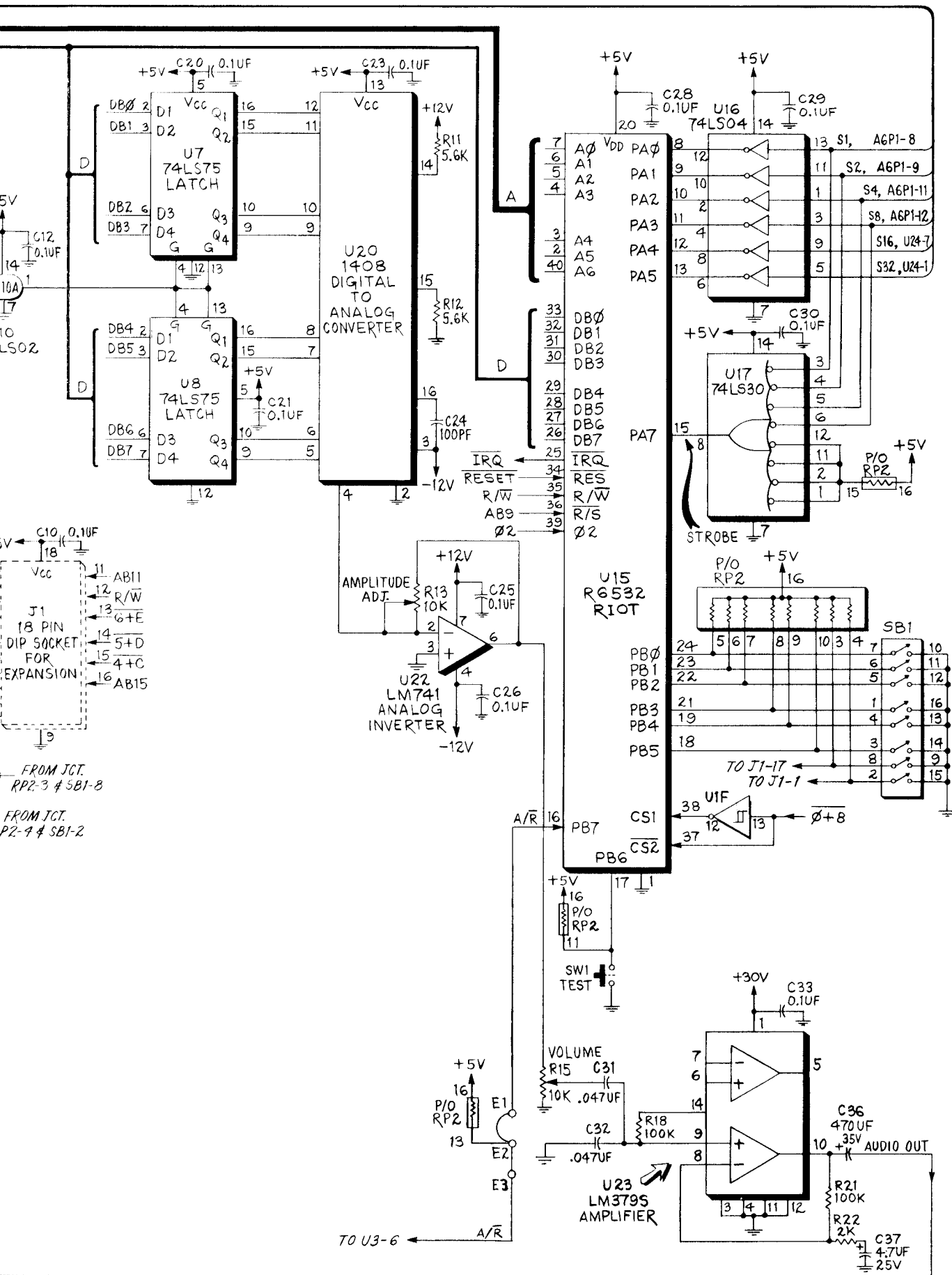

SOUND BOARD ASSY. (A6), SCHEMATIC DIAGRAM