

Online Radio & Electronics Course

Reading 7

Ron Bertrand VK2DQ
<http://www.radioelectronicschool.com>

SERIES-PARALLEL CIRCUITS

In many circuits, some components are connected in series to have the same current, while others are in parallel for the same voltage. When analysing and doing calculations with series-parallel circuits you simply apply what you have learnt from the last two readings.

In the circuit of figure 1 below, we could work out all the voltages across all of the resistances and the current through each resistance and then total resistance. For now I am just going to walk through the simplification of this circuit to a single resistance connected across the 100 V source.

Keep in mind that any circuit (resistive) can be reduced to a single resistance. This is particularly useful when we come to do transmission lines and antennas.

For now let's have a go at simplifying the circuit of figure 1. There are many ways to go about this problem. The method I prefer is to start at the right hand side and work my way back to the source, simplifying the circuit as I go.

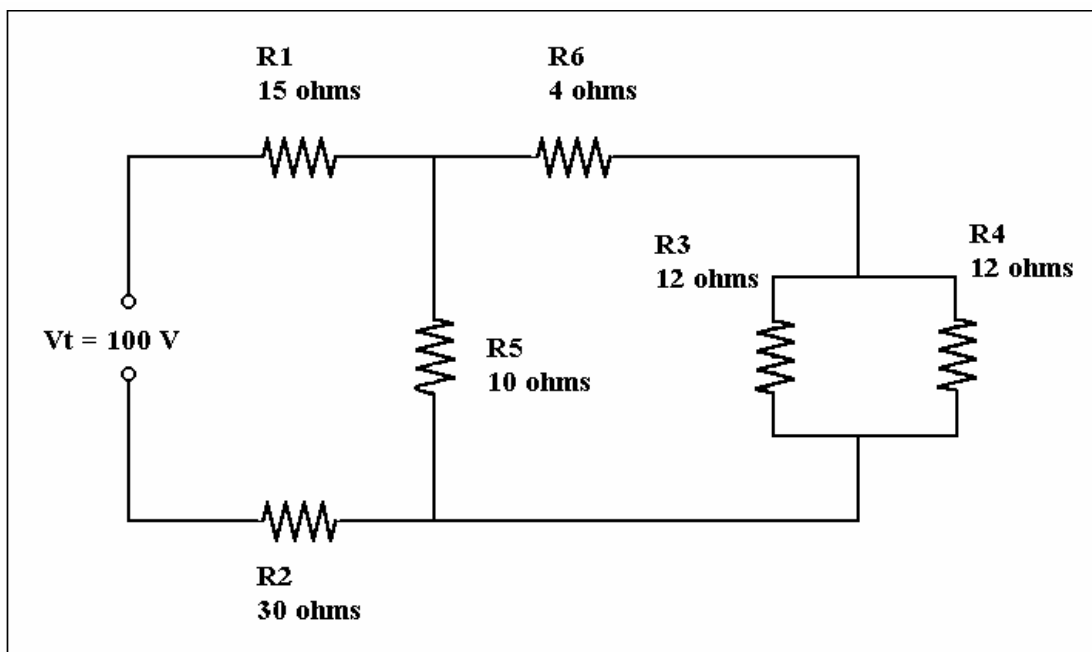

Figure 1.

On the right hand side we see R_3 and R_4 in parallel and each 12Ω . Do you remember the short cut method when parallel resistances are all the same value? Divide the value of the branch by the number of branches: $12\Omega / 2 = 6\Omega$.

Replace the parallel pair of R_3 and R_4 with a single resistance R_7 as shown in figure 2.

Always redraw the circuit...

Figure 2.

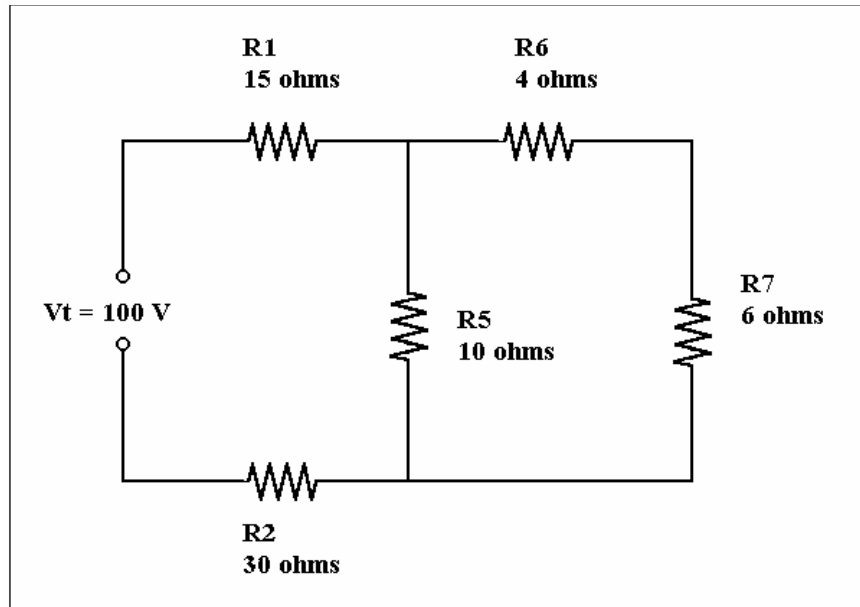

The next logical step would be to combine the series resistance of R_6 and R_7 into a single resistance R_8 by adding them, as shown in figure 3: $4\Omega + 6\Omega = 10\Omega$.

Redraw the circuit....

Figure 3.

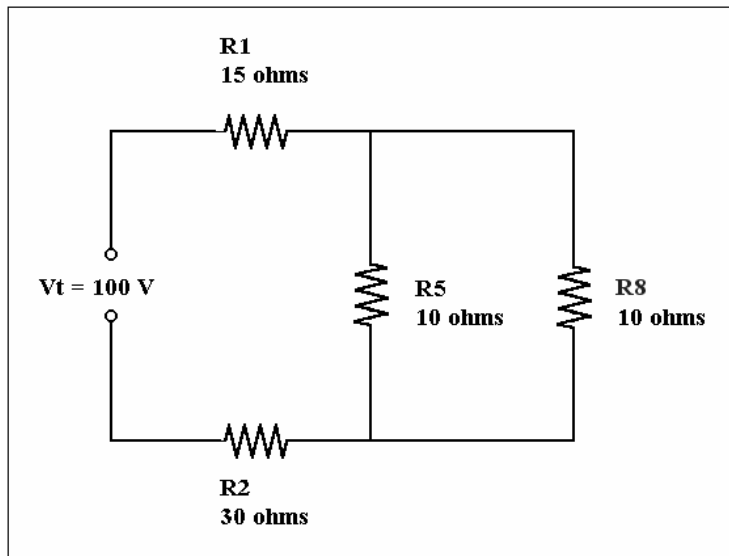

Now combine the parallel and equal resistances of R_5 and R_8 into a single resistance R_9 of 5Ω as shown in figure 4, and of course, redraw the circuit.

Figure 4.

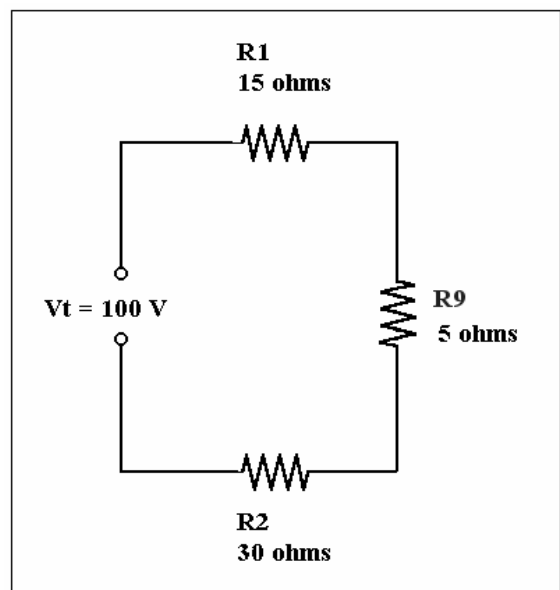

We are now left with a series circuit consisting of R_1 , R_2 and R_9 . We find the total resistance of these by summing them: $15\Omega + 30\Omega + 5\Omega = 50\Omega$.

You guessed it! **Redraw the circuit** again for our final result shown in figure 5.

So the total resistance of the circuit we started with is equivalent to a single resistance of 50Ω .

We could now find out how much current is being drawn by the circuit from the supply, by using Ohm's law:

$$I = E/R = 100/50 = 2 \text{ Amperes.}$$

That's it! You will find that most circuits, even very complex ones, can be handled in the same manner i.e. by simplifying series and parallel branches as you work your way down to a single resistance.

I cannot emphasise enough the need to redraw the circuit as you work your way through it. The calculations for this circuit were easy arithmetically. If it were not so easy, then it is important to show all of your working out as well.

[Refer to the circuit of figure 1. What is the voltage across \$R_4\$?](#)

We know that the total resistance of the circuit is 50Ω and from this we worked out that the current drawn from the supply was 2 A.

Therefore if we go back to the figure 1 circuit, R_1 (15Ω) and R_2 (30Ω) must have 2 A flowing through them since they are in series with the supply.

The voltage across R_1 will be: $E = IR_1 = 2 \times 15 = 30 \text{ V}$.

Likewise, the voltage across R_2 will be: $E = IR_2 = 2 \times 30 = 60 \text{ V}$.

Now if there is 30 volts across R_1 and 60 volts across R_2 then this leaves $100 - 30 - 60 = 10$ volts across R_5 .

R_5 is in parallel with R_6 and the parallel pair of R_3 and R_4 .

R_3 and R_4 simplify to 6Ω .

So we have 10 volts across 4Ω and 6Ω in series. The voltage across the 6Ω will be the voltage across R_4 (and R_3 for that matter).

Some may see immediately without any calculation that 10 volts across a series combination of a 4Ω and a 6Ω resistor will result in 4 volts across the 4Ω and 6 volts across the 6Ω . If you can't see this then don't worry, let's solve it using Ohm's law.

Figure 5.

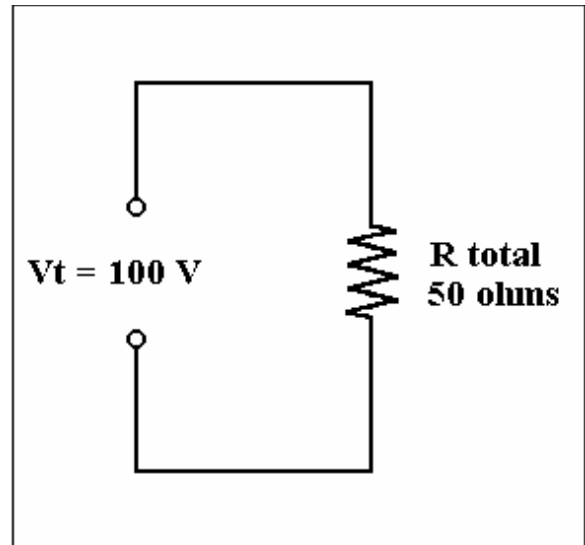

$$I = E / R = 10/10 = 1 \text{ ampere.}$$

So there is 1 ampere flowing through the 6Ω resistance that represents the combined resistance of R_3 and R_4 in parallel.

$$E = I \times R = 1 \times 6 = 6 \text{ volts.}$$

Therefore, the voltage drop across R_4 is 6 volts.

COMPARISON OF SERIES AND PARALLEL CIRCUITS

SERIES CIRCUIT	PARALLEL CIRCUIT
The current in all parts of the circuit is the same.	The voltage is the same across all parallel branches.
E across each series R is $I \times R$.	I in each branch is E/R .
The sum of the voltage drops equals the applied voltage. $E_t = E_1 + E_2 + E_3 \text{ etc.}$	The sum of the branch currents equals the total current. $I_t = I_1 + I_2 + I_3 \text{ etc.}$
$R_t = R_1 + R_2 + R_3 \text{ etc.}$	$1/R_t = 1/R_1 + 1/R_2 + 1/R_3 \text{ etc.}$
R_t must be the larger than any individual R.	R_t must be less than the smallest branch R.
$P_t = P_1 + P_2 + P_3 \text{ etc.}$	$P_t = P_1 + P_2 + P_3 \text{ etc.}$
Applied voltage is divided into IR drops.	Main current is divided into branch currents.
The largest voltage drop is across the largest resistance.	The largest branch current is through the smallest parallel R.
Open circuit in one component causes the entire circuit to be open.	Open circuit in one branch does not prevent current in other branches.

Table 1 – Comparison of Series and Parallel Circuits

End of Reading 7.

Last revision: November 2001

Copyright © 1999-2001 Ron Bertrand

E-mail: manager@radioelectronicschool.com

<http://www.radioelectronicschool.com>

Free for non-commercial use with permission