

● TRAK 10



Operation and Maintenance Manual



WARRANTY

Seller warrants that its printed circuit boards and parts thereon are free from defects in material and workmanship under normal use and service for a period of ninety (90) days from date of shipment. Seller warrants that its television monitors are free from defects in material and workmanship under normal use and service for a period of thirty (30) days from date of shipment. None of the Seller's other products or parts thereof are warranted.

If the products described in this manual fail to conform to this warranty, Sellers' sole liability shall be, at its option, to repair, replace, or credit Buyer's account for such products which are returned to Seller during said warranty period, provided:

(a) Seller is promptly notified in writing upon discovery by Buyer that said products are defective;

(b) Such products are returned prepaid to Sellers' plant; and

(c) Seller's examination of said products discloses to Seller's satisfaction that such alleged defects existed and were not caused by accident, misuse, neglect, alteration, improper repair, installation or improper testing.

In no event shall Seller be liable for loss of profits, loss of use, incidental or consequential damages.

EXCEPT FOR ANY EXPRESS WARRANTY SET FORTH IN A WRITTEN CONTRACT BETWEEN SELLER AND BUYER WHICH CONTRACT SUPERSEDES THE TERMS OF THIS ORDER, THIS WARRANTY IS EXPRESSED IN LIEU OF ALL OTHER WARRANTIES EXPRESSED OR IMPLIED, INCLUDING THE IMPLIED WARRANTIES OF MERCHANTABILITY AND FITNESS FOR A PARTICULAR PURPOSE, AND OF ALL OTHER OBLIGATIONS OR LIABILITIES ON THE SELLER'S PART, AND IT NEITHER ASSUMES NOR AUTHORIZES ANY OTHER PERSON TO ASSUME FOR THE SELLER ANY OTHER LIABILITIES IN CONNECTION WITH THE SALE OF PRODUCTS UNDER THIS ORDER.

This document is and contains confidential trade secret information of Atari, Inc.

This document is loaned under confidential custody for the sole purpose of operation, maintenance or repair of Atari equipment and may not be used by or disclosed to any person for any other purpose whatever, and remains the property of Atari, Inc.

Neither it nor the information it contains may be reproduced, used, or disclosed to persons not having a need to know consistent with the purpose of the loan, without written consent of Atari, Inc.

TABLE OF CONTENTS

| | Page No. |
|---|-------------|
| A. Introduction and Warranty Information | 1 |
| B. Access and Basic Construction | 1 |
| C. New Machine Set-up and Check-out. | 1 |
| D. The Game Sequence | 2 |
| E. The Antenna and The Anti-static Modification . . . | 3 |
| F. Top Section Sub-Assemblies: | |
| Service Procedures | 3 |
| G. The Coin Door: Service Procedures | 4 |
| ● Coin Acceptors | 4 |
| ● Rejector Linkage | 4 |
| H. Electronics Tray Sub-assemblies: | |
| Service Procedures | 5 |
| I. The Control Panel: Service Procedures | 5 |
| ● The Gear Shifter | 5 |
| ● The Pedal Assembly | 5 |
| ● The Steering Wheel Assembly | 6 |
| J. General Maintenance | 6 |
| K. Troubleshooting | 6 |

LIST OF ILLUSTRATIONS

| Figure | Subject |
|--------|------------------------------|
| 1. | Trak 10; Side View |
| 2. | Trak 10; Front View |
| 3. | General Illumination Lamps |
| 4. | TV Monitor Adjustments (2) |
| 5. | Coin Door |
| 6. | Coin Acceptors (2) |
| 7. | Gear Shifter (2) |
| 8. | Pedal Assembly |
| 9. | Steering Wheel Assembly |
| 10. | Wiring Diagram |
| 11. | TV Monitor Schematic Diagram |
| 12. | Electronics Tray Assembly |

A. INTRODUCTION AND WARRANTY INFORMATION

Trak 10 is a coin operated video amusement device which simulates the experience of driving a high speed race car around a difficult track. All the machine controls (steering, gear shift, accelerator and brakes) behave like those of a real car.

The electronics of this game are solid state for long life and low maintenance. The mechanical assemblies (steering, gear shifter and pedals) have been designed modularly for easy removal and servicing.

However, as with all devices mechanical or electrical, there may be minor problems. *If the printed circuit board computer (PCB) fails within the warranty period, contact the distributor from whom the game was originally purchased for repair or replacement instructions.*

Any PCB repair attempted by anyone other than authorized Atari Service Center personnel will void the PCB warranty.

For the Atari warranty on the Trak 10 game, please see the inside front cover of this manual.

B: ACCESS AND BASIC CONSTRUCTION

Three openings: Coin door, rear door and a swing-out front control panel—provide convenient access to all sub-assemblies and adjustment points. Opening the coin door exposes all the coin handling equipment—the coin acceptors and rejector linkages, the coin counter and the coin box. The rear door is used to service the TV monitor, the pedal assembly and the components mounted to the electronics tray—the PCB, the transformers and the fuses.

An interlock switch is mounted to the electronics tray and turns off the entire machine when the rear door is opened.

The interlock switch protects the operator from accidental shock, so it must always be kept in perfect working order. If you need to test or adjust the machine with the rear door open, place the interlock switch in the closed or "on" position by pulling out the white actuator shaft.

All the major sub-assemblies have been designed modularly for easy servicing or replacement. The control panel, the pedal assembly, the Trak 10 computer and the TV monitor can each be removed after the wiring and release bolts have been removed.

C: NEW MACHINE SET-UP AND CHECK OUT PROCEDURES

Before turning this machine on, inspect it carefully for any damage which may have occurred during shipping.

As each new Trak 10 leaves the factory, every component and sub-assembly is carefully checked for proper operation and adjustment. However, since parts may have been damaged or adjustments changed during shipping, the following check out procedure must be repeated prior to placing the machine on location.

1. With the machine unplugged, open both access doors and carefully inspect both the exterior and interior of the machine for any obvious shipping damage to the cabinet or internal components and sub-assemblies. If any such damage is discovered, contact the carrier

immediately. Then contact the distributor from whom the game was originally purchased for repair or replacement instructions.

2. Inspect the interior of the machine more carefully looking for broken or disconnected wires, sub-assemblies pulling loose or not firmly mounted and any foreign objects shorting electrical connections. Pay particular attention to the connections to the TV monitor, the control panel and the coin door. Also make sure that the PCB edge connector and the fuse are firmly seated. Note: The plug is located inside the cabinet for shipping purposes, and should be fed through the 1 1/2" hole located at the right lower bottom portion of the cabinet.

3. Plug in the machine and if the rear door panel is off,

defeat the interlock switch by pulling out the white actuator shaft. At this point the CRT (Cathode Ray Tube) should display the race track and the score after a short warm up time. Examine the CRT picture. It should be steady, sharp and exhibit the proper levels of brightness and contrast.

4. Insert several old *and* new coins into each coin acceptor. No genuine coin should be rejected. Pressing the game credit switch (start switch) advances the coin counter one digit. Operate both coin rejector handles and check for any signs of binding or sticking. Finally, check to see that both acceptors are firmly mounted in their frames. NOTE: Lightly spray both coin acceptors and both sets rejector linkages with WD-40, a silicone lubricant. This bit of preventative maintenance may save a service call later.

5. Start a game by pressing the start switch button and check for proper game sequence making sure all aspects of the game (steering, gear shifter, accelerator, brakes, score, timer and track display) are functioning correctly. If you are not familiar with the game sequence for Trak 10, read the game sequence analysis.

6. Adjusting play time modifies crash mode. The play time is pre-set at the factory for approximately 1 minute 40 seconds, and should not be changed.

7. Both doors (rear and cash) should open and close without binding, and both door locks should turn to the "locked" and "unlocked" positions freely.

8. Check the rear door interlock switch to see that it turns off the machine when the door is opened.

D: THE GAME SEQUENCE

With the game plugged in and the rear door installed, the CRT will display the *attract* mode. The attract mode for Trak 10 displays the race course and a stationary race car positioned where the last player ended, plus the score of the previous game and the game timer (which should read 0). At the point the score is reset to 0, the timer begins counting down from 78 by 2s, the car engine begins idling and is ready to be driven.

The controls of the machine and the movement of the car image simulate those of a real car. Once accelerated, the car becomes increasingly difficult to stop the faster the car is moving.

Turning the steering wheel causes the car to turn in the direction of rotation. The car will turn only while the steering wheel is being rotated.

The gear shifter works exactly like that of a real car. Use reverse gear to back off of the pylons after a crash. Then shift into first, rotate the steering wheel to turn the car so it will continue in the proper direction and step on the accelerator pedal. Once the engine has revved to its limit, shift into second and once the engine has revved to its limit, shift into third. The speed of the car will climb as you shift through the gears. Keep in mind, though, that the engine will "bog" down if you shift up too fast or start out in the wrong gear (2nd or 3rd).

Both the accelerator and brakes have only two positions: on or off. When the accelerator is depressed, the engine will rev up. Stepping on the brake pedal will bring the car to a screeching halt and if the steering wheel is turned as the brakes are applied, the car will skid realistically.

Points are scored only by passing the course check points in the proper sequence as indicated by the arrows on the CRT. The score is displayed at the top next to the game timer.

If the car is driven into any of the pylons, a crash will result. The crash is accompanied by a crash sound, uncontrolled spinning of the car during which time the car cannot be driven. As soon as the crash sound has ended, shift into first and continue driving the car in the proper direction. The game continues in this fashion until the game timer reaches 0 at which point the controls become "dead" and the machine is reset to the attract mode.

Players are given an indication of their skill by matching their score (points) against the 'rating card' located at the lower part of the instruction plate. This rating system is based on a game playtime of approximately one minute and forty-five seconds (as adjusted prior to shipment). The rating card reads:

YOUR SCORE

| | |
|----------|-----------------|
| 0-10 | License Revoked |
| 11-20 | Backseat Driver |
| 21-30 | Good |
| 31-40 | Excellent |
| Above 40 | Real Pro |

If game playtime is readjusted by the operator, this point/rating system is no longer valid.

E: THE ANTENNA WIRE AND ANTI-STATIC MODIFICATION

An *electronic latch* circuit has been incorporated in the Trak 10 computer. One function of this circuit is to turn off or prevent game credit if a player tries to obtain free games by inducing a static charge in the machine. The *antenna wire* is an integral part of this system.

When a static discharge occurs, an electric current is induced in the antenna wire. This impulse is transmitted through the antenna wire to the electronic latch circuit which turns off game credit and resets the computer to the attract mode.

The antenna wire is a length of white wire approximately 12 inches long. One end of the antenna is connected to pin K of the PCB edge connector and the other end has been intentionally left not connected.

The length of the antenna wire has been pre-adjusted by the factory to the overall optimum length, however some environments may require more or less critical adjustment.

Lengthening the antenna wire increases the sensitivity of the circuit; cutting the wire shorter decreases the sensitivity.

If players are obtaining free games by including static charges in the machine, lengthen the antenna wire (add a piece of wire) by a few inches so that a lesser charge will turn off game credit. If you have problems with static charges accidentally turning off game credit during the progress of a legitimate game, try cutting the antenna shorter in increments of 1-2 inches. Try to cut only the minimum amount off the antenna, otherwise players may be able to obtain free games.

The anti-static modification may be tested during a game by touching the end of the antenna wire with your finger as the body usually has enough capacitance to actuate the electronic latch. If the game is shut off, the circuit is functioning correctly.

F: TOP SECTION SUB-ASSEMBLIES: SERVICE PROCEDURES

Use the following procedures to replace the general illumination lamps, the plexiglass screen and bezel and to service the TV monitor.

1. **GENERAL ILLUMINATION LAMPS:** Eight 6 volt lamps are mounted on a PC board behind the plexiglass screen to illuminate the Trak 10 instruction plate. To replace burned out lamps, reach in the rear door and unscrew the four lamp PC board mounting screws (#21, Fig. 1) and unplug the 2 wires which are attached to it at the plugs located in the upper left inside area of the cabinet. Remove the panel and replace burned out lamps with GE44 or GE47 lamps.

2. **PLEXIGLASS SCREEN:** Use procedure #1 to remove the lamp PCB. Then remove the three wing nuts and carriage bolts (#20 & 36, Fig. 1) which hold down the upper aluminum plexiglass screen retainer (#5, Fig. 1) and lift out the plexiglass.

3. **BEZEL:** Use procedures #1 and #2 to remove plexiglass and the bezel (#2, Fig. 1) will lift out.

4. **TV MONITOR:** To remove the entire TV monitor assembly (#40, Fig. 1), remove the four Phillips head bolts and nuts (#25 & 27, Fig. 1) found on the top of the monitor frame. *Do not remove the aluminum angle brace at the bottom rear.* Disconnect the electrical connector to the TV and lift the monitor out very carefully. DISCHARGE THE SECOND ANODE BEFORE SERVICING.

5. **TV MONITOR ADJUSTMENT:** The TV monitor

and its adjustment controls function like any normal TV set with the exception of the sound which is adjusted on the PCB (see page 5). The monitor is serviced through the rear door of the machine. See figure 4 on Page 12 for the locations of the following adjustments:

a. **Brightness:** Adjust the brightness *before* the contrast. Adjust so that the CRT background is as *dark as possible*.

b. **Contrast:** The contrast is adjusted so that the CRT images are *as bright as possible* against the pre-adjusted dark background *without being blurred*.

c. **Vertical Hold:** Adjust only *if the picture appears to be rolling* up or down the screen. Adjust for a stable centered picture.

d. **Horizontal Hold:** Adjust *if the picture is slightly off center horizontally*, if the images appear *warped* or if the picture is *broken into a series of diagonal lines*.

e. **Vertical Size:** Adjust only *if the top and bottom of the race course is cut off* from the screen or if there is too much distance between the edge of the course and the edge of the screen, which will appear as an extra set of horizontal dotted lines on the top and bottom of the CRT display. Adjust for maximum picture size.

f. **Vertical Linearity:** Change this adjustment *only if the top of the picture seems compressed*.

g. **The Yoke:** *The yoke should never need adjustment unless the adjuster have been tampered with* or the machine damaged. If yoke adjustment is indicated,

adjust both yoke rings *simultaneously* for optimum centering of the race course on the CRT.

h. **The A.C. Voltage Switch:** Set this switch to the 115 Volt position ("115" visible on the switch) if the machine is connected to a 115 Volt source. *The TV monitor will not function if this switch is misadjusted.*

G: THE COIN DOOR: SERVICE PROCEDURES

All coin handling equipment is accessible through the front door. To collect the coins, open the door, remove the coin box and record the meter reading.

The Trak 10 is equipped with two coin acceptor assemblies so the entire machine will not be out of service if one acceptor is malfunctioning.

Please keep in mind that proper adjustment and lubrication of the coin handling equipment will help minimize your service calls.

1. **THE DOOR LOCK:** The lock cylinder can be withdrawn and replaced after the rear retaining nut and the lock cam are removed. If the coin door does not fit tightly or the lock does not turn freely, try bending the lock cam slightly with a pair of pliers. NOTE: The lock cylinder should be lubricated once every three months or so with graphite or WD-40.

2. **THE REJECT LINKAGE:** A separate reject button operates the wiper lever of each coin acceptor. When this button is pushed in, the wiper lever (#17, Fig. 6d) of the coin acceptor is operated which should dislodge any coins stuck in the acceptor. The rejector button cannot be removed. NOTE: Lubricate the rejector linkage with silicone grease when you receive the machine and thereafter at approximately six month intervals.

3. **THE COIN MICRO SWITCHES:** To remove a malfunctioning micro switch, unscrew the two retaining screws (#1, Fig. 6a), record the wire positions and pull off the slip-on connectors.

4. **THE COIN ACCEPTORS:** The coin acceptor can be removed for servicing after the retaining screw (#2, Fig. 6b) has been removed.

5. ACCEPTOR ADJUSTMENT AND MAINTENANCE:

ADJUSTMENT: All coin acceptors leave the factory adjusted for maximum performance. However, if more critical adjustments are necessary or if the unit has been completely disassembled for service, the following adjustment procedure is suggested:

(These tests and adjustments are performed with the acceptor in a vertical position on a level surface [the rest position].)

i. **The TV Monitor Fuses:** Two 6/10 Amp, 125 Volt Slo-Blo fuses (313 3AG) protect the TV monitor from electrical overload. Replace blown fuses *only* with those which have the above rating. NOTE: The TV is not fused by the fuse on the electronics tray.

KICKER AND SEPARATOR

1. Set the unit with the back of the acceptor facing you in the test position.
2. Loosen the screws holding the kicker (1) and the separator (3) and move both the kicker (2) and the separator (4) as far to the right as they will go. Tighten the screws.
3. Insert several test coins (both old and new) and note that some are returned by striking the separator.
4. Loosen the separator screw and move the separator a slight amount to the left. Tighten the screw.
5. Insert the test coins again and, if some of them are still returned, repeat Step #4 until all the coins are accepted.
6. Loosen the kicker screw and move the kicker as far to the left as it will go. Tighten the screw.
7. Insert the test coins and note that some are returned.
8. Loosen the kicker screw and move the kicker a slight amount to the right.
9. Insert the test coins again and, if some are still returned, repeat Step #8 until all the coins are accepted.
10. Be sure that both screws are tight after the adjustments have been made.

THE MAGNET GATE

1. Set the acceptor with the front of the unit facing you in the test position.
2. Turn the magnet gate adjusting screw (#12, Fig. 6d and #3, Fig. 6a) out (counterclockwise) until none of the coins will fit through.
3. With a coin resting in the coin entrance of the acceptor (#4, Fig. 6c), turn the adjuster in (clockwise) until the coins barely passes through the magnet gate.
4. Test this adjustment using several other coins (both old and new) and, if any of them fail to pass through the magnet gate, repeat Step #3 until all of the coins are accepted.
5. Fix the magnet gate adjusting screw in this position by tightening down the magnet gate screw lock nut.

ACCEPTOR MAINTENANCE: Depending on the environment in which the acceptor is used, periodic preventive maintenance should be performed.

The mainplate (#5, Fig. 6d) may be cleaned with any non-abrasive household cleaner. Rinse and dry thoroughly to remove deposits and film.

Remove all metal particles from the magnet by

guiding the point of a screwdriver along the edges of the magnet.

Remove the transfer cradle (#9, Fig. 6d) and clean the bushing and pivot pin. A pipe cleaner is an effective cleaning tool. Apply powdered graphite or pencil lead to the pin and bushing and reassemble.

Spray the entire unit lightly with WD-40 or a similar silicone lubricant.

H: ELECTRONICS TRAY SUB-ASSEMBLIES: SERVICE PROCEDURES

(PULL OUT THE POWER CORD WHILE PERFORMING PROCEDURES 1-4.)

1. **FUSE REPLACEMENT:** Replace the bad fuse with a Slo-Blo fuse rated at 1 Amp, 125 Volts (313 3AG).

2. **TRANSFORMER REPLACEMENT:** To remove a malfunctioning transformer remove the AC protective cover, record all wire colors and their positions, unsolder the wiring and unscrew the retaining screws. NOTE: When installing the new transformer, be sure to reconnect the chassis ground wire (lugs fastened with wood screws that mount the transformers to the wood electronics tray).

3. **INTERLOCK SWITCH:** To remove the switch, pull off the push-on connectors, squeeze in side tabs on the switch and push it through the mounting bracket.

4. **PRINTED CIRCUIT BOARD:** To remove the PCB, disconnect the PCB edge connector, remove the four retaining screws and carefully lift out the board. PCBs

are extremely fragile and require very careful handling.

5. PCB ADJUSTMENTS:

a. **Volume:** This adjustment is made by a small blue trim pot marked "volume" near PCB position L8. Adjust the volume to the preference of the location but keep in mind that the machine will sound louder with the door off.

b. **Play Time:** This adjustment is located near A8 and it adjusts both the total play time and the crash time period. Playtime is pre-set before shipment and *should not be adjusted* due to interrelationships with other game functions (i.e., crash time, rating system).

If you have the following symptoms, recalibration of one or more of the cemented pots is indicated and you must return the board to your distributor:

1. If the car seems to move too slow
2. If the sound of the engine revving up is distorted
3. If the sound of the car coming to a stop with the brakes applied (the "screech" sound) is distorted.

I: THE CONTROL PANEL: SERVICE PROCEDURES

1. **CONTROL PANEL:** To service the rear of the control panel, reach through the back of the cabinet and remove the two wing nuts at the top rear of the panel. The control panel will then hinge out and down.

2. **GEAR SHIFTER ASSEMBLY:** To remove gear shifter from the control panel, first open the control panel as per procedure #1. Then record the wire colors and their positions or later reference and pull off all the slip-on connector to the shift switches. Shift assembly can be withdrawn through the front of the control panel after the four retaining screws have been removed.

To open the gear shifter assembly, remove the four machine screws (Fig. 7) while holding the housing halves together with your fingers. Split the housing halves carefully so internal parts will not spring out and become lost. With the housing halves separated, the

gearshift rod (#3, Fig. 7), spring (#7, Fig. 7), ball (#15, Fig. 9), detent (#4, Fig. 7) and switch actuators (5, Fig. 7) will all be accessible. NOTE: When re-assembling the unit, lubricate the ball with a small amount of silicone grease and be sure that you replace the housing screws the same way they came out.

3. **THE PEDAL ASSEMBLY:** The pedal assembly must be removed to replace the brake and accelerator switches. Reach in the rear door and remove three wing nuts (#44, Fig. 2). From the front of the machine, grasp the protruding lip of the pedal assembly and pull out the entire unit.

To replace pedals (#2, Fig. 8), remove the four pedal retaining screws and lift off pedal. To replace switches, reach through the bottom of the pedal box and remove the wires and the two screws (#14 Fig. 8). Be sure to

record all wire colors and positions before removing them from the switches.

4. **STEERING WHEEL ASSEMBLY:** To service or remove steering wheel assembly, open the control panel as per procedure #1. To replace the wheel, remove the shaft end nut (#14, Fig. 9). Lift off the slotted tack ring (16) and withdraw the steering wheel through the front of the control panel. If only the wheel needs replacement, remove the cap (#2) and the shaft (#4). The cap will lift off when retaining screws (#6) are removed and the shaft can be disassembled when retaining nut (#9) is removed. NOTE: When reassembling the unit, lu-

bricate the bearings (#11 and #12) with a small amount of silicone grease and when re-installing the shaft, be careful not to push out the rear bearing. Tighten shaft end nut.

To replace the steering assembly PCB, remove shaft end nut and tack ring. The PCB can be replaced after the retaining screws (#7, Fig. 9) are removed.

To replace the steering wheel bushing assembly, use procedure 4 to remove the steering wheel, then remove the six retaining screws which hold the backing plate to the control panel. Withdraw the bushing assembly through the front of the panel.

J: GENERAL MACHINE MAINTENANCE

Due to its solid state circuitry, your game will require very little maintenance other than periodic cleaning, lubrication and TV monitor adjustment.

The cabinet and plexiglass screen may be cleaned with any non-abrasive household cleaner. The coin

acceptors, rejector linkages and the lock cylinders should be lightly sprayed once every three months with WD-40 or a similar silicone lubricant. The TV monitor is adjusted *only* if the CRT picture is distorted or if the contrast or brightness are out of adjustment.

K: TROUBLESHOOTING PROCEDURES

3. **THE WIRING HARNESS:** For troubleshooting purpose, the harness includes the line cord, the fuse, the A.C. line filter, the transformers, the interlock switch, the antenna wire, the start and coin switches, the steering assembly, the gear shifter, the pedal assembly, the PCB edge connector, the TV monitor, the speaker and all the interconnecting lengths of wire. A wiring enclosure diagram of the wiring harness and associated components has been included at the end of this manual to aid in troubleshooting.

4. **SUGGESTIONS:** Following are some specific instructions and suggestions for troubleshooting your Trak 10. To perform even the most simple troubleshooting procedures, you must have a VOM (Volt-Ohmmeter) and, if possible, a VTVM (Vacuum Tube Volt Meter) or digital voltmeter. It is also very helpful to have another GT 10 game (or a spare TV monitor and PCB) available for substitution purposes.

For many problems, *substitution* may be the easiest way to troubleshoot the machine. For example, if you suspect a PCB malfunction, try substituting another and known-to-be-good PCB. If the malfunction disappears, the first PCB must have been cause. Conversely, if the malfunction persists, the cause of the malfunction must be located in either the TV or the harness

The TV monitor can also be checked by substitution.

The first step in any troubleshooting procedure is to correctly identify the observable symptoms of the malfunction. With these clues in mind, examine the areas of the machine which might cause these symptoms.

It is helpful for troubleshooting purposes to isolate three areas:

1. **THE TV MONITOR:** Many TV problems can be rectified with proper TV adjustment. However, if the problem persists or if the TV is undoubtedly malfunctioning, contact your distributor or remove the TV monitor and take it to a competent local TV repair shop. Complete TV monitor repair manuals are available free of charge from the Atari Customer Service Department, 14600 Winchester Blvd. Los Gatos, CA 95030. Phone: (408) 374-2440/Telex: 357-488.

2. **THE PCB COMPUTER:** Most PCB malfunctions will not be within your scope to repair. If you can positively determine that your PCB computer has failed, contact the distributor from whom you purchased the game for repair or replacement instructions. Please be aware that some symptoms which might appear as PCB malfunctions may be the result of improper TV monitor adjustment or misadjustment of the small blue trim pots located on the PCB. *Do not attempt to repair the PCB yourself unless you have been specifically instructed to do so by your distributor.* To do otherwise will void your PCB warranty.

Simply connect the game to a known-to-be-good monitor and if the malfunction is cleared up, the first monitor must have been the cause.

Harness must be checked by elimination. Substitute a known-to-be-good TV and PCB, and if the malfunction persists, the harness and associated mechanical or electronic equipment must be at fault.

5. TV MONITOR TROUBLESHOOTING: Some typical TV problems are distorted display, raster only or no video at all.

If you do not have a raster (a raster is a lighted but blank TV screen with the brightness turned all the way up), begin checking the power supply to determine if the TV is getting power. If the general illumination lamps of the machine are lighted, at least you know that power is reaching the machine. If not, check your line cord, interlock switch, fuse, etc.

If it is A.C. powered, go around to the back of the machine and with the rear door open (and interlock switch defeated) listen for a hum emanating from the monitor. If there is a hum, the monitor is powered and you may have a defective CRT or similar problem. Another test (and one which can be performed in a noisy environment) is to measure the voltage between the TV fuses and ground. If your voltmeter reads 110 volts or more, you know the monitor is powered. If not, check the fuses, the TV connections and the harness to see why power is not reaching the monitor. If the TV is powered but still not functioning, check the TV AC voltage switch which should be set to the "115" position ("115" visible on the switch) if it is connected to a 110 volt line source.

If you have the correct voltage after the fuses, but the monitor still will not function, you have two choices: 1). Remove the monitor and take it to a specialist, or 2). turn to the TV schematic (page 20) and start exploring the monitor with a VTVM and an oscilloscope.

If you do have a raster, you must determine why there are no video signals being displayed on the screen. These video signals are generated by the PCB computer and enter the monitor through pin 1 of the TV monitor connector.

6. STEERING ASSEMBLY TROUBLESHOOTING:

Two small red LEDs have been included on the main PCB near position H8 to aid in troubleshooting the steering electronics.

Mounted on the small steering assembly PCB are two phototransistors and two infrared light emitting diodes. The phototransistors are mounted behind the tack ring in such a way that the slots in the wheel break up the light emitted from the diodes. This generates pulses which are used by the computer to determine how quickly and in which direction the wheel is being turned.

The test LEDs on the main PCB will light whenever the infrared diodes are stimulating the phototransistors (i.e. whenever the diodes are "shining" through the slots in the slotted wheel onto the transistors).

To test the steering wheel assembly, simply rotate the wheel slowly in both directions while watching the two red LEDs on the main PCB. If your steering assembly is O.K., both LEDs will flicker. If both of the LEDs fail to light (or remain lit constantly) while wheel is being turned, you definitely have a malfunction *before* the main PCB, which may be either in the wiring harness or in the steering assembly PCB.

7. TROUBLESHOOTING BY SYMPTOM:

a. **No Power:** Check for correct line voltage and if O.K. then check the fuse on the electronics tray, interlock switch and the transformer primaries.

b. **No TV Picture:** Check for power as per procedure 1 (NO POWER) and if O.K., check TV connector and TV fuses. Measure voltage at TV fuses (should be 110 VAC) and if O.K., replace the TV monitor.

c. **TV Raster Only:** Check the harness and especially the PCB edge connector. If O.K., check the TV as per the special test under "TV troubleshooting". Or check TV or PCB by substitution.

d. **TV Picture Rolls:** Adjust the TV vertical hold and if the rolling persists, check the TV or the PCB by substitution.

e. **TV Picture Is Wavy:** Adjust the TV horizontal hold and if the problem persists, try replacing the transformer (in the TV monitor itself).

f. **TV Picture Is Broken Into Diagonal Lines:** Adjust the TV horizontal hold and if the problem persists, check the TV or the PCB by substitution.

g. **No Game Start:** Check the coin switches, the start switch, the harness and replace the PCB if necessary.

h. **Game Shuts Off Accidentally:** Try cutting the antenna wire shorter in increments of 1-2 inches.

i. **Picture Shrinks:** Check the line voltage with your VOM and be aware that a large motor starting up (i.e. an air conditioner) may drop the line voltage. Check to see that machine is firmly plugged in. If the problem only occurs at certain times of the day (especially at dusk), your trunk line voltage may be dropping.

j. **No Audio:** Check the volume control, speaker connections and for 20 volts. If the problem persists, test the speaker and if the speaker is O.K. try replacing the PCB.

k. **Game Sequence Incorrect, Parts of The Race Course, Car, Score or Timer Missing or Distorted:** Replace the PCB or check for proper power supply as described in "Troubleshooting the Power Supply".

m. **Car Will Not Steer or Turn in One Direction Only:** Check PCB LEDs as per procedure on page 7 and if O.K., then replace the PCB computer. If LED test is O.K., check steering harness and connections and for foreign matter in steering assembly. Replace steering PCB if necessary.

n. **No Brakes:** Check brake switch and wires from brake pedal switch to PCB. If O.K., replace the PCB.

o. **Brakes All The Time:** Check brake switch for foreign material and/or shorting terminals.

p. **No Accelerator:** Follow procedure 14 for "NO BRAKES".

q. **Accelerator All The Time:** Follow procedure 15.

r. **All Four Gears Dead:** Check connections and wires from gearshifter to PCB and if O.K., replace the PCB.

s. **One, Two or Three Gears Dead:** Check the connections and harness of the malfunctioning gear(s); check the shift switch(s) for the malfunctioning gear(s). If problem persists, replace the PCB.

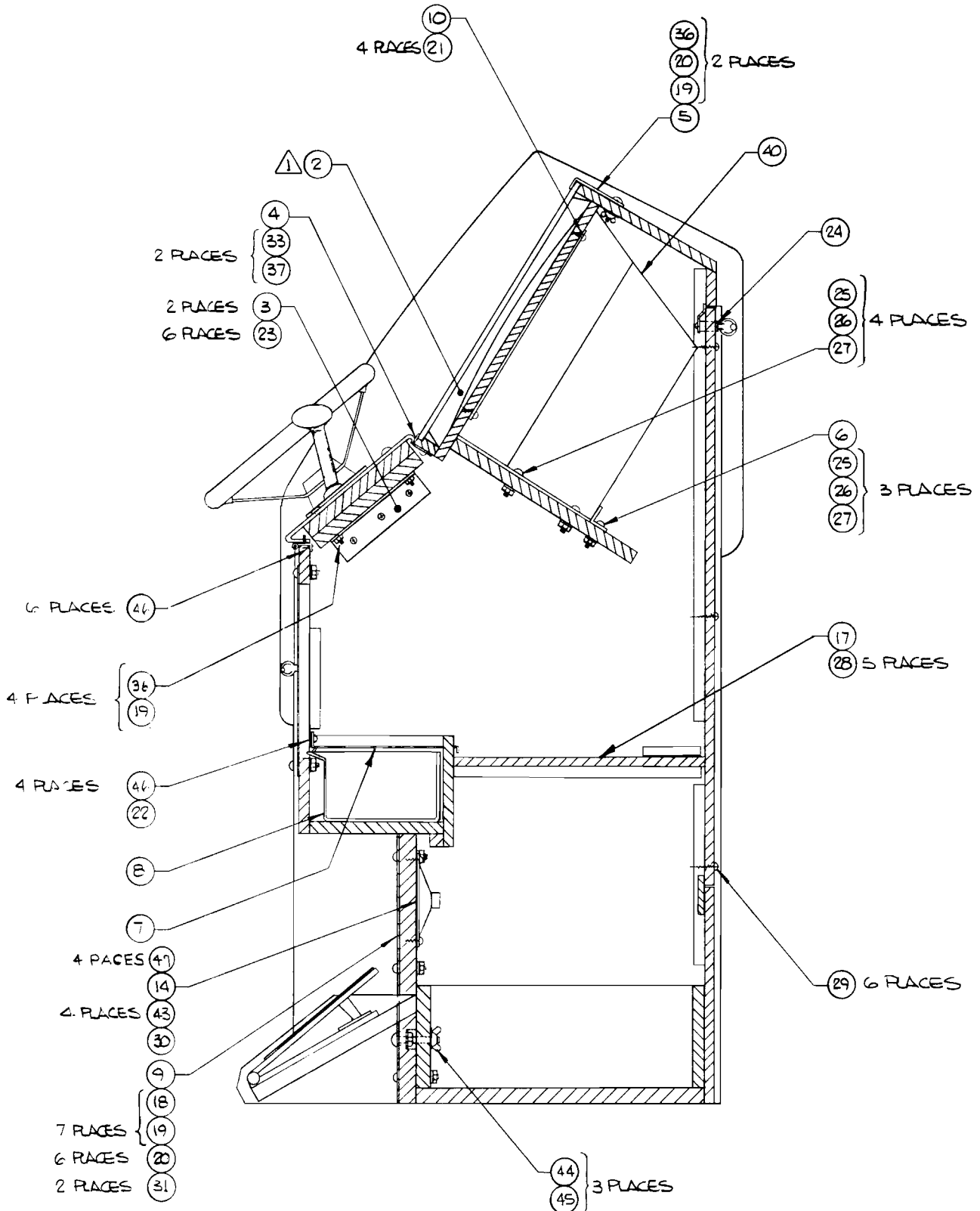

⚠ ITEM 32, 39, 41 & 42 ARE LOCATED IN ITEM 38 TO BE APPLIED TO CRT (ITEM 40) PRIOR TO MOUNTING OF PLEX SHIELD ASSY (ITEM 11).

Figure 1. Trak 10; Side View

List of Materials

| Item | Part No. | Qty. | Description |
|------|----------------|------|---|
| 1 | A001619 | 1 | Cabinet Assy |
| 2 | 001656 | 1 | Bezel |
| 3 | 001638 | 2 | Bracket, Panel, Mtg |
| 4 | 001574 | 1 | Lower Plex Retainer |
| 5 | 001573 | 1 | Upper Plex Retainer |
| 6 | 000533 | 1 | Angle, TV, Retainer |
| 7 | 001639 | 1 | Cover, Cash Box |
| 8 | 000536 | 1 | Cash Box |
| 9 | 001637 | 1 | Kick Plate |
| 10 | A001508 | 1 | Illumination Assy |
| 11 | A001622 | 1 | Front Plex Shield |
| 12 | A001561 | 1 | Control Panel Assy |
| 13 | A001592 | 1 | Cash Door Assy 8</td |
| 14 | 000898 | 1 | Speaker Grill |
| 15 | 001657 | 1 | Instruction Plate |
| 16 | A001658 | 1 | Foot Pedal Assy |
| 17 | A001506 | 1 | Electronics Tray Assy |
| 18 | 75106/75-9115 | 11 | Nut, Hex, Steel, 10-24 |
| 19 | 75107/75-0105 | 17 | Washer, Flat, Steel 10 |
| 20 | 75817/ | 12 | Bolt, Carriage, 10-24x1" lg (Blk Oxide) |
| 21 | 75200/75-7604 | 4 | Screw, SMS, Pan Hd, Phil 6x½ lg |
| 22 | 83035/71-301 | 1 | Staple, Lock |
| 23 | 75158/75-8816 | 6 | Screws, SMS Rnd Hd, Phil 8x¾ lg |
| 24 | 83030/71-2112 | 1 | Lock Mechanical, Barrel Cart |
| 25 | 75174/72-18205 | 7 | Screw, Mach, Pan Hd, 8-32x1¼ lg Phil |
| 26 | 75130/75-0185 | 7 | Washer, Flat, Steel, 8 |
| 27 | 75105/75-9185 | 7 | Nut, Hex, Steel, 8-32 |
| 28 | 75310/ | 5 | Screw, Wood, Rnd Hd, 8x1½ lg Phil |
| 29 | 75321/75-8020 | 6 | Screw, Wood, Flat Hd, 10x1¼ lg Phil |
| 30 | 80087/ | 1 | Speaker |
| 31 | 75825/ | 2 | Bolt, Carriage, 10-24x1½ lg (Blk Oxide) |
| 32 | 001636 | 1 | Decal, Oil Slick |
| 33 | 75302/ | 2 | Screw, Wood, Steel Rnd Hd, Phil 8x½ lg |
| 34 | 000873 | Ref | Schematic Diagram |
| 35 | 001664 | Ref | Enclosure Diagram |
| 36 | 75145/75-931 | 6 | Wingnut 10-24 |
| 37 | 75130/75-0185 | 2 | Washer, Flat, Steel 8 |
| 38 | 001665 | Ref | CRT Decal Locations |
| 39 | 83260/ | 5 | Arrows |
| 40 | 92015/ | 1 | 19" Motorola Monitor (XM50J) |
| 41 | 001678 | 1 | Decal, Time |
| 42 | 001677 | 1 | Decal, Miles |
| 43 | 75240 | 4 | Screw, Sht Metal, Pan Hd 6x¾ lg Phil |
| 44 | 75220 | 3 | Wingnut ¼-20 |
| 45 | 75217 | 3 | Washer, Flat, Steel ¼ |
| 46 | 75324 | 10 | Screw, Wood, Flat Hd, 8x½ lg Phil |
| 47 | 75102 | 4 | Washer, Flat, Reg. Pattern 6 |

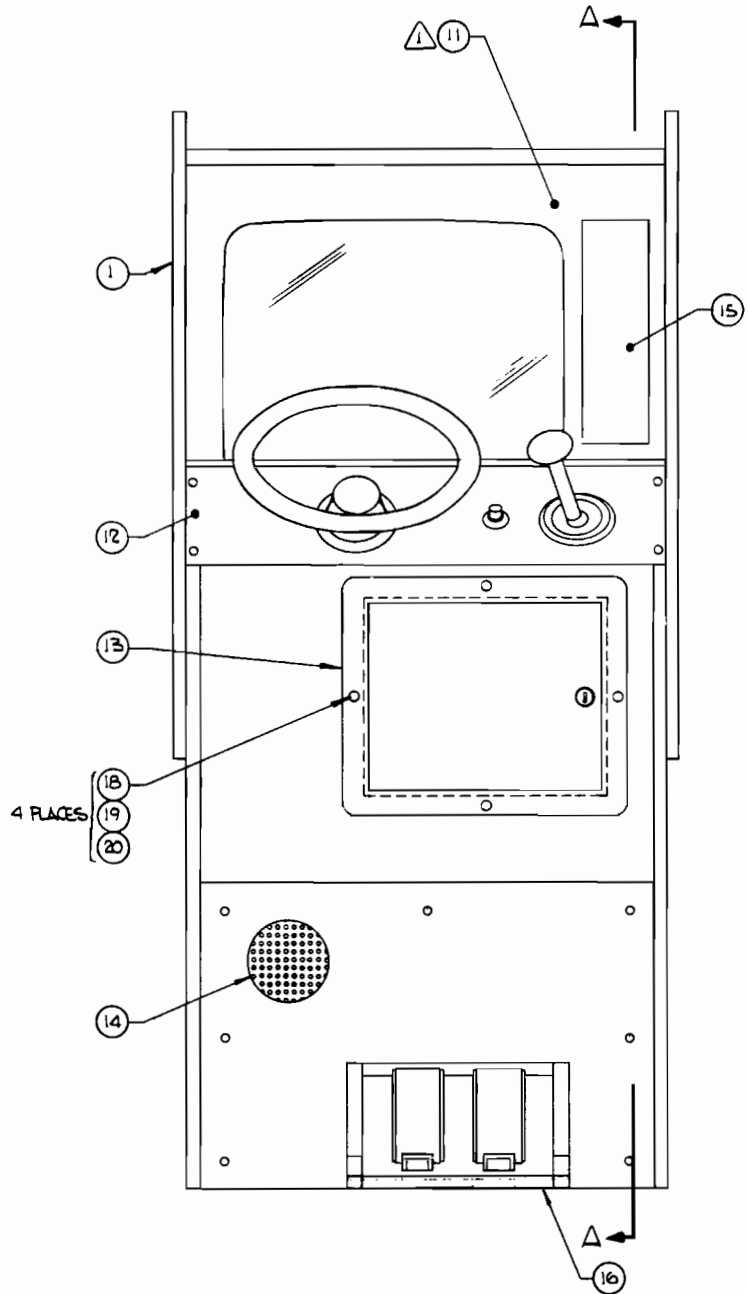
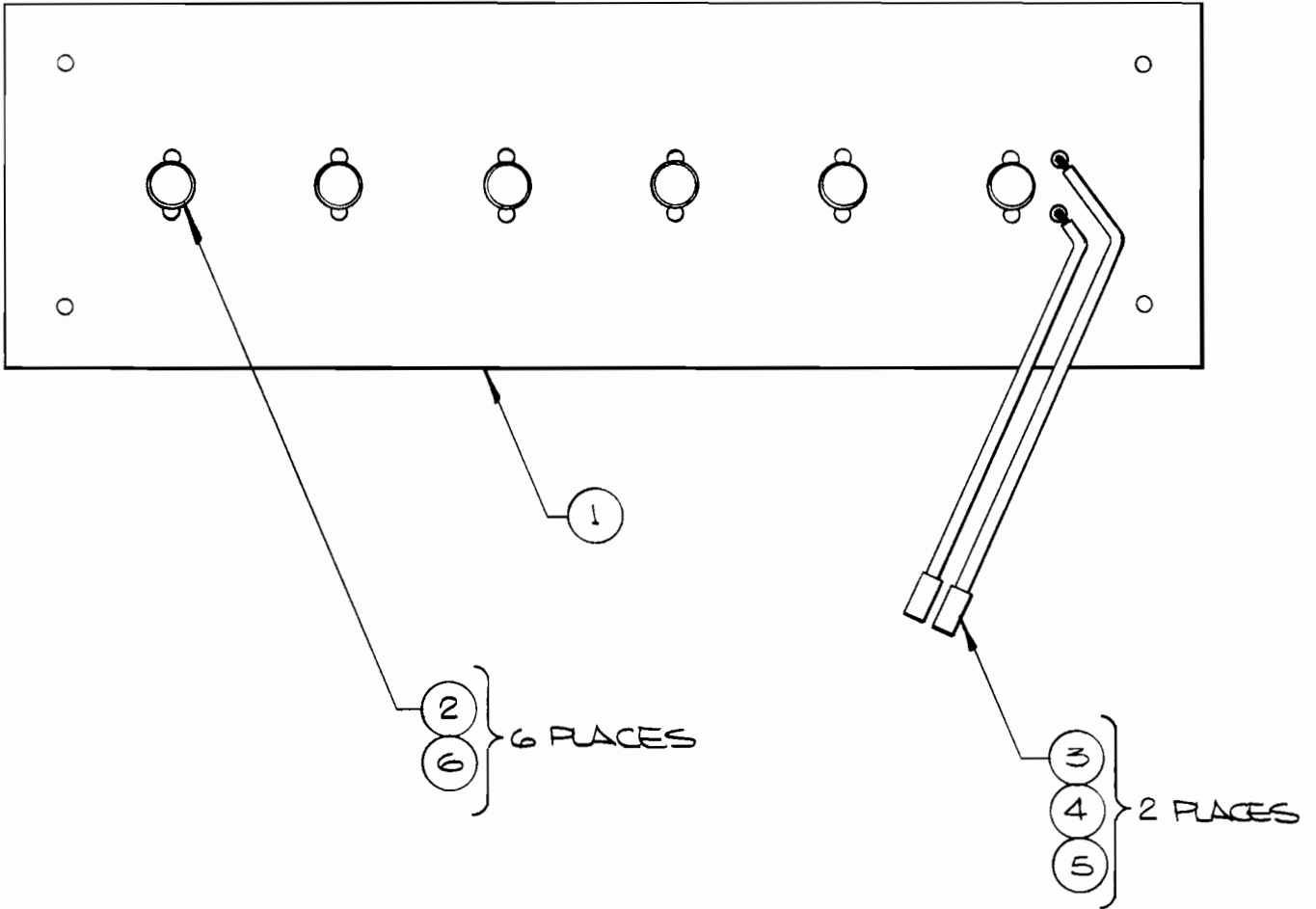

Figure 2. Trak 10; Front View



List of Materials

| Item | Part No. | Qty. | Description |
|------|----------|------|------------------------------------|
| 1 | 001507 | 1 | PC Board Illumination |
| 2 | 80026 | 6 | Lamp, Incandescent Nema 47 |
| 3 | 83267 | 2 | Contact Pin, End Feed AMP |
| 4 | 80084 | 2 | Single Circuit AMP Housing, Female |
| 5 | 77037 | 24'' | 18 Ga. Red Wire |
| 6 | 80033 | 6 | Socket Lamp, 7-35 Lee |

Figure 3. General Illumination Lamps

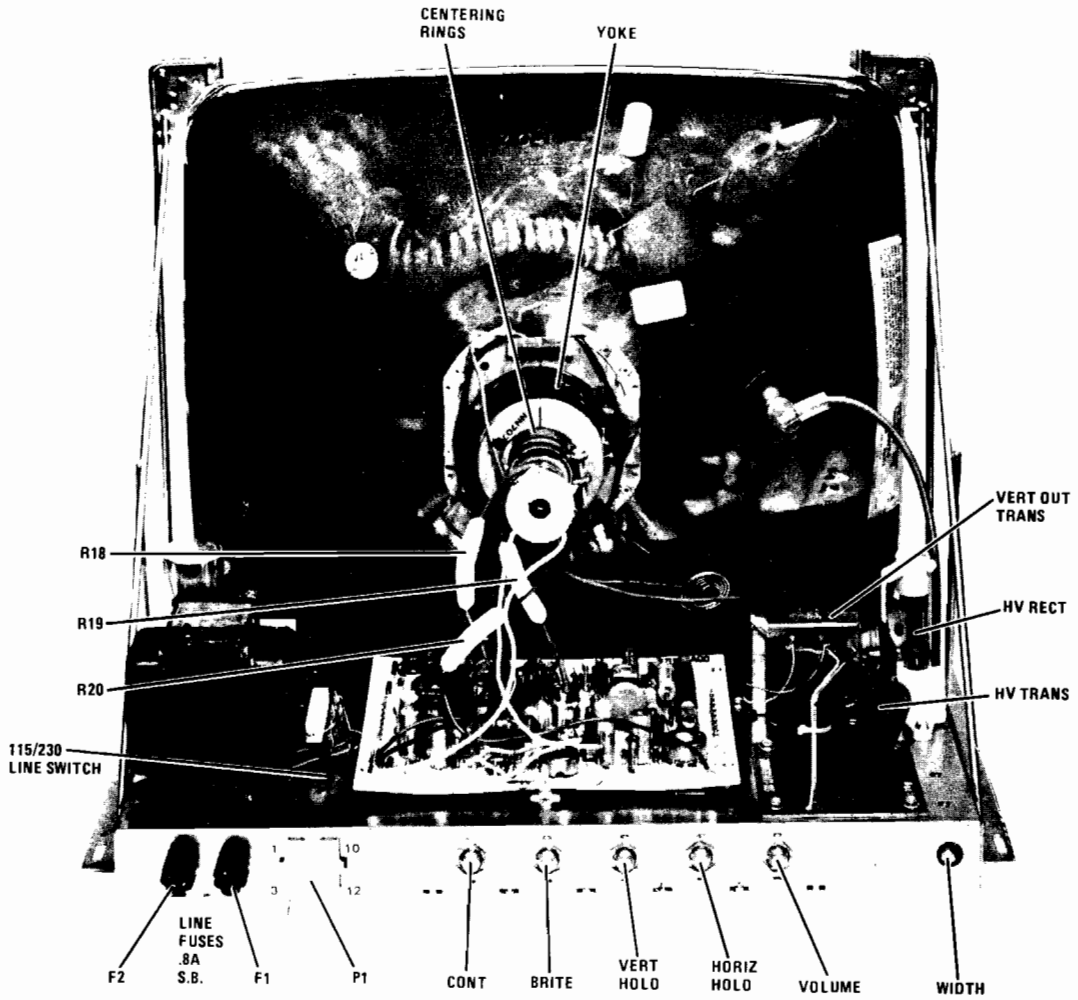

XM501/701 CHASSIS REAR VIEW

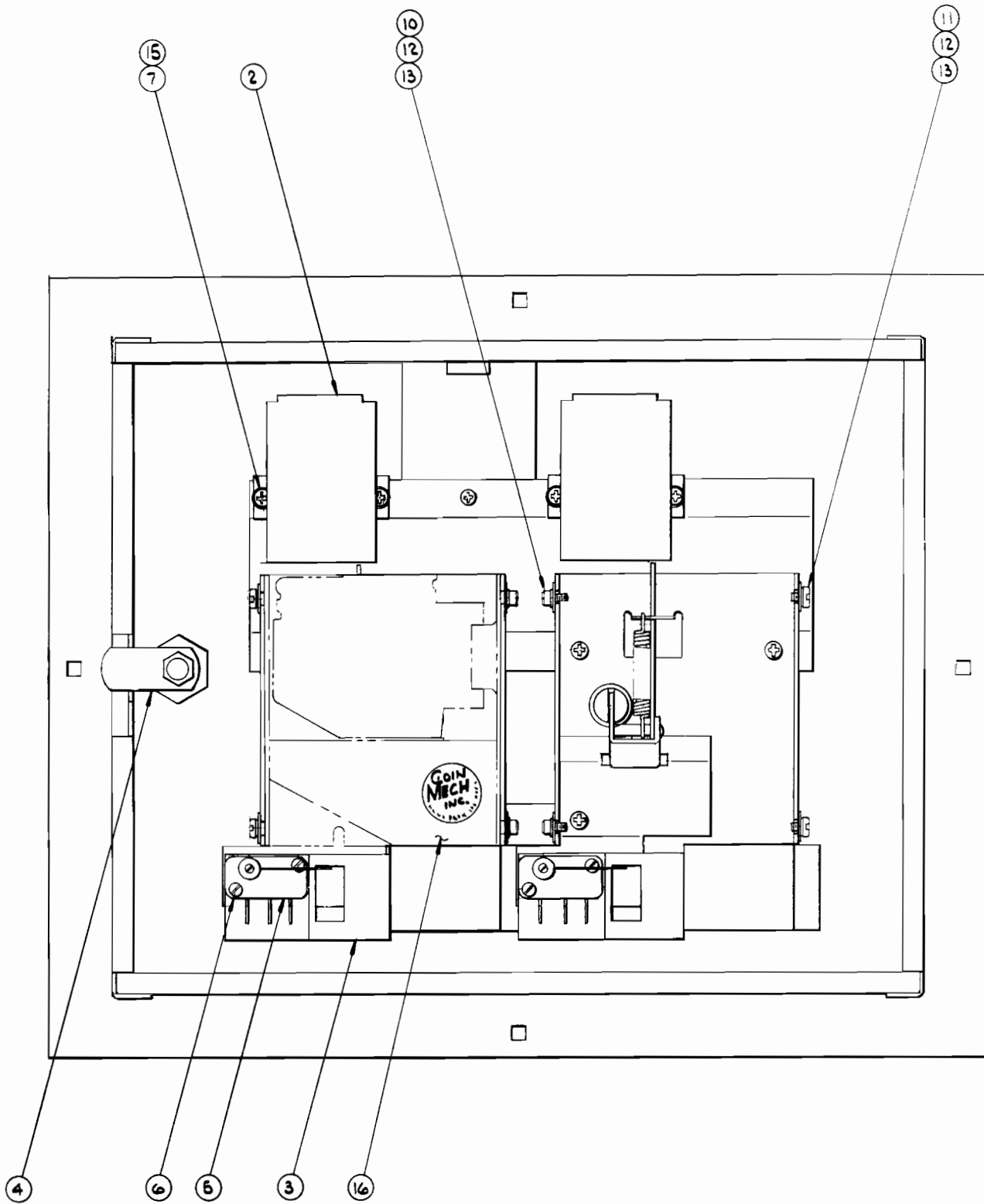

Figure 5. Coin Door

Figure 6b

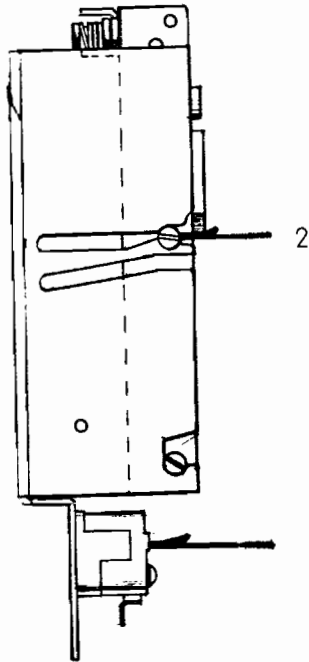

Figure 6a

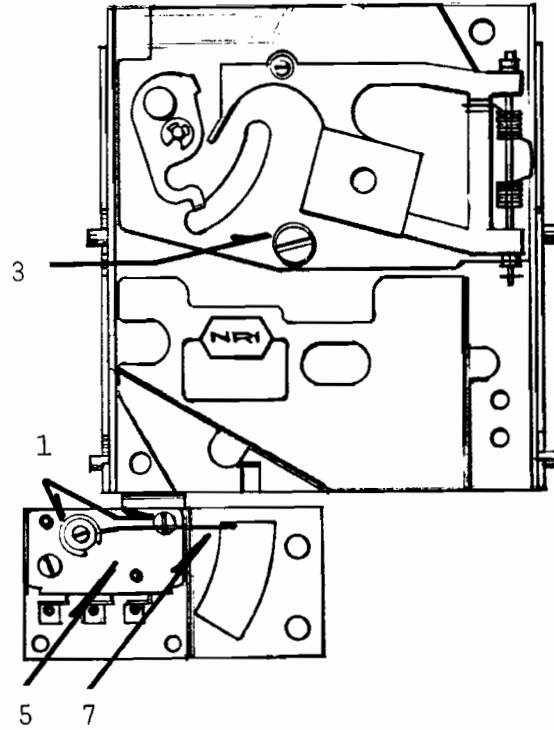
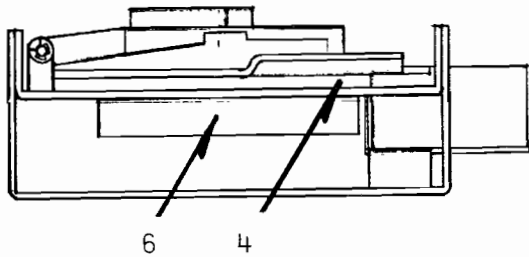
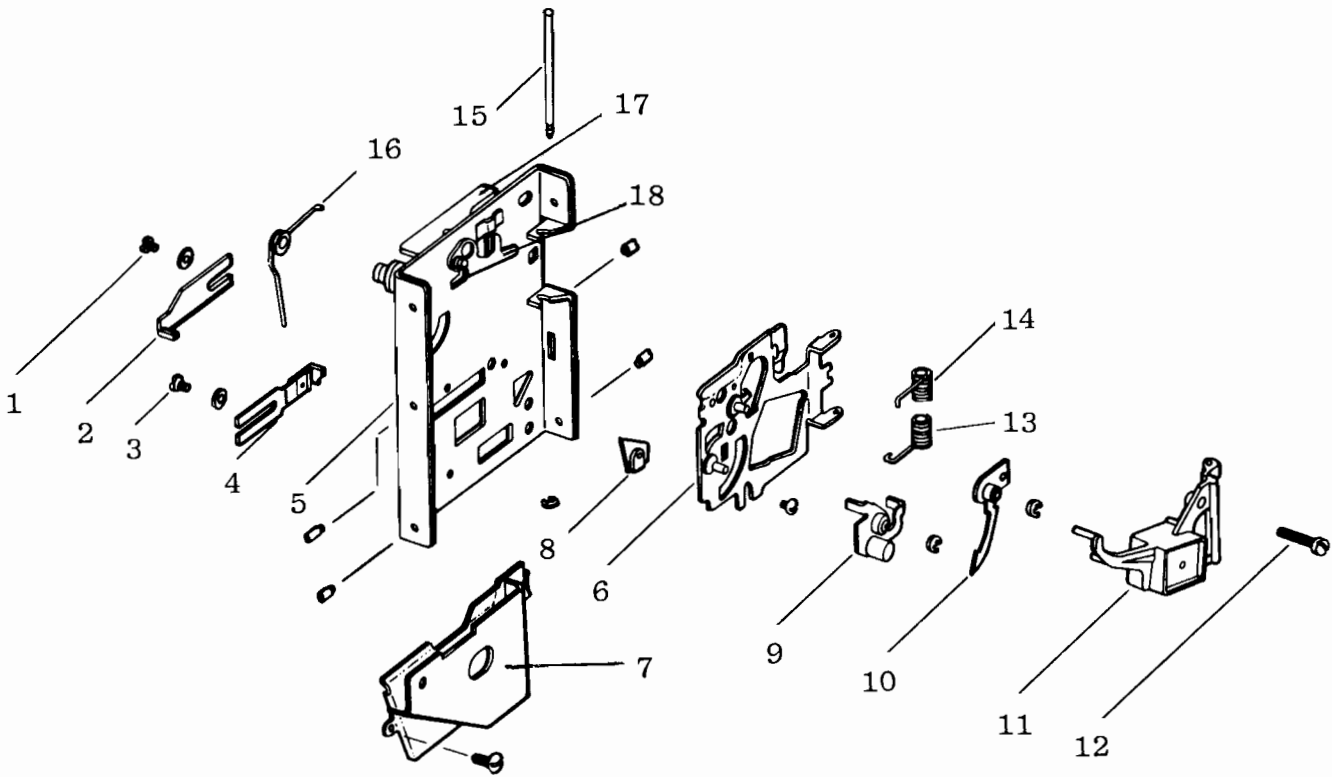

Figure 6c



- 1. COIN SWITCH RETAINING SCREWS
- 2. COIN ACCEPTOR RETAINING SCREW
- 3. MAGNET GATE ADJUSTER
- 4. COIN ENTRANCE
- 5. COIN SWITCH
- 6. WIPER LEVER
- 7. TRIP WIRE

Figure 6. Coin Acceptor



List of Materials

| Item | Description |
|------|-------------------------|
| 1. | Kicker Screw |
| 2. | Kicker |
| 3. | Separator Screw |
| 4. | Separator |
| 5. | Mainplate Assembly |
| 6. | Gate Assembly |
| 7. | Coverplate Assembly |
| 8. | Rail |
| 9. | Cradle Assembly |
| 10. | Undersize Lever |
| 11. | Magnet Assembly |
| 12. | Magnet Gate Adjuster |
| 13. | Lower Gate Pivot Spring |
| 14. | Upper Gate Pivot Spring |
| 15. | Gate Pivot Pin |
| 16. | Wiper Lever Spring |
| 17. | Wiper Lever |
| 18. | Wiper |

Figure 6d. Coin Acceptor (Exploded View)

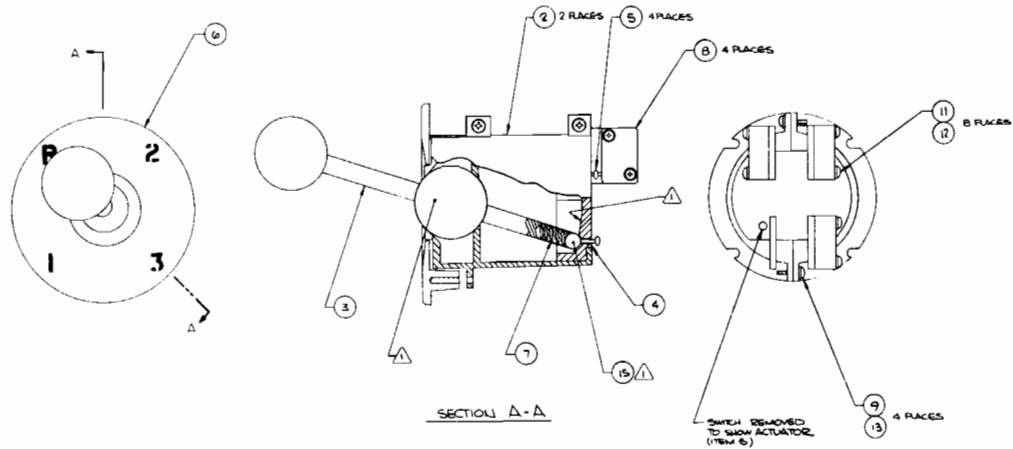

NOTES:
 A APPLY LIGHT SHEAR OF SHIFTER SPRINGS
 # 5 CONTROL AND (OR EQUAL) OIL AREAS INDICATED.

List of Materials

| Item | Part No. | Description |
|------|----------|-------------------|
| 1. | 000608 | Shift Assembly |
| 2. | 000609 | Shift Housing |
| 3. | A000610 | Handle Assembly |
| 4. | 000611 | Shift Detent |
| 5. | 000628 | Shift Rivet |
| 6. | 000612 | Shift Bezel |
| 7. | 83241 | Spring |
| 8. | 60004 | Cherry Switch |
| 9. | 75129 | Washer, Flat, 6 |
| 10. | | |
| 11. | 75163 | Washer, Flat, 4 |
| 12. | 75800 | Screw, 4-40 x 3/4 |
| 13. | 75801 | Screw, 6-32 x 1/2 |
| 14. | | |
| 15. | 75407 | Ball, Steel, 3/8 |

Figure 7. Gear Shifter

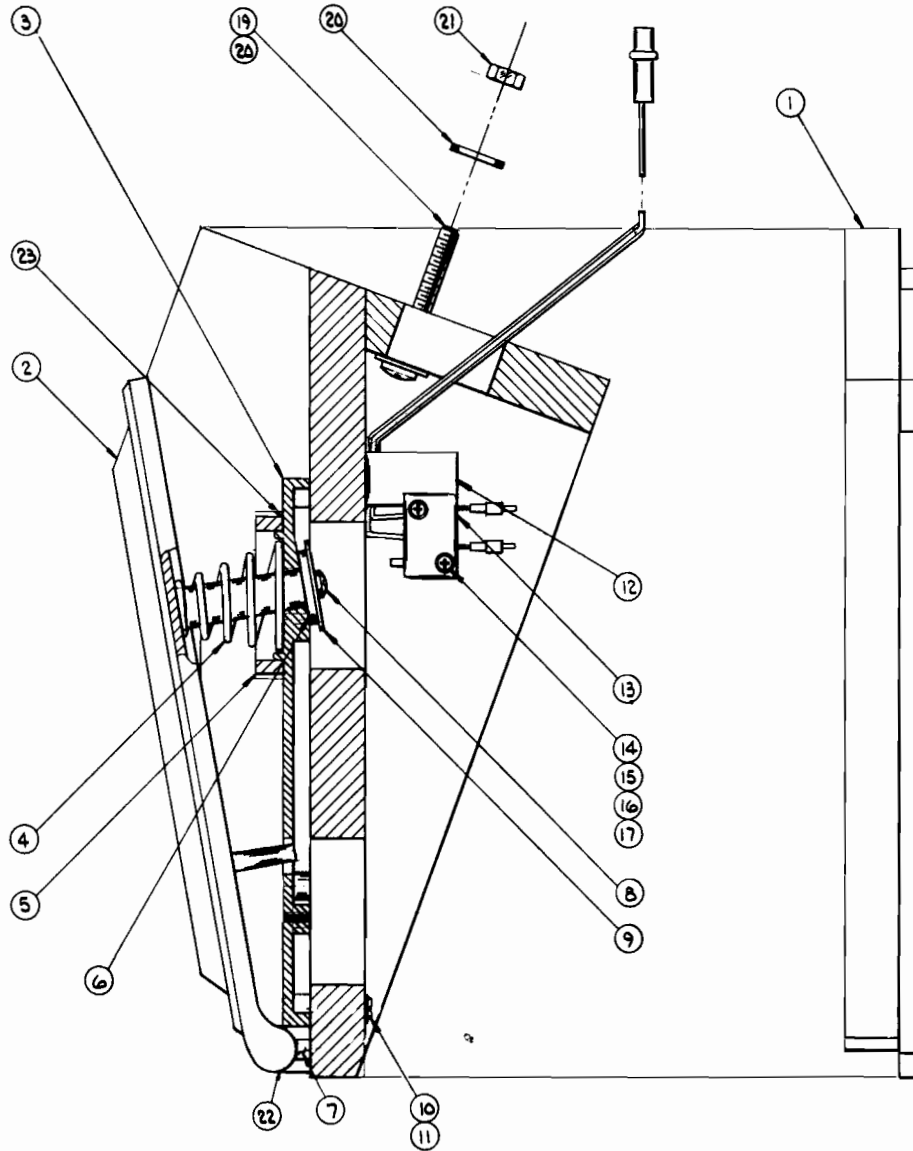

List of Materials

| Item | Part No. | Qty. | Description |
|------|----------|------|---|
| 1 | A001631 | 1 | Box, Assembly |
| 2 | 000590 | 2 | Foot Pedal (3201-3533) |
| 3 | 000591 | 2 | Pedal Foot (3201-3534) |
| 4 | 000592 | 2 | Spring (3201-3550) |
| 5 | 000593 | 2 | Bumper (3201-3551) |
| 6 | 000594 | 2 | Stop Washer (3201-3552) |
| 7 | 000597 | 2 | Bearing Block (3201-3549) |
| 8 | /75199 | 2 | Screw, Mach., Pan Hd., Phil., 1/4-20x1 1/2" Lg. |
| 9 | /75409 | 2 | Washer, Fender 1/4 |
| 10 | /75174 | 8 | Screw, Mach., Pan Hd., 8-32x1 1/4" Lg. |
| 11 | /75102 | 8 | Washer, Flat, 6 |
| 12 | 001069 | 2 | Switch, Bracket |

| | | | |
|----|-----------|-----|--|
| 13 | /80011 | 2 | Switch, Cherry (G-18-04A) |
| 14 | /75811 | 4 | Screw, Mach., Rd., Hd., Phil., 4-40x3/4" Lg. |
| 15 | /75163 | 4 | Washer, Flat, 4 |
| 16 | /75162 | 4 | Washer, Lock, 4 |
| 17 | /75164 | 4 | Nut, Hex, 4-40 |
| 18 | /75302 | 2 | Screw, Wood, Rd. Hd., Phil., 8x1/2" Lg. |
| 19 | /75808 | 3 | Screw, Mach., Pan Hd., Phil., 1/4-20x2" Lg. |
| 20 | /75131 | 3 | Washer, Flat, 1/4 |
| 21 | /75155 | 3 | Nut, Hex, 1/4-20 |
| 22 | /83268 | A/R | Silicone Grease Compound 5 |
| 23 | /84012 | A/R | Contact Cement |
| 24 | 001662-01 | 1 | Harness, Foot Pedal |

Figure 8. Pedal Assembly

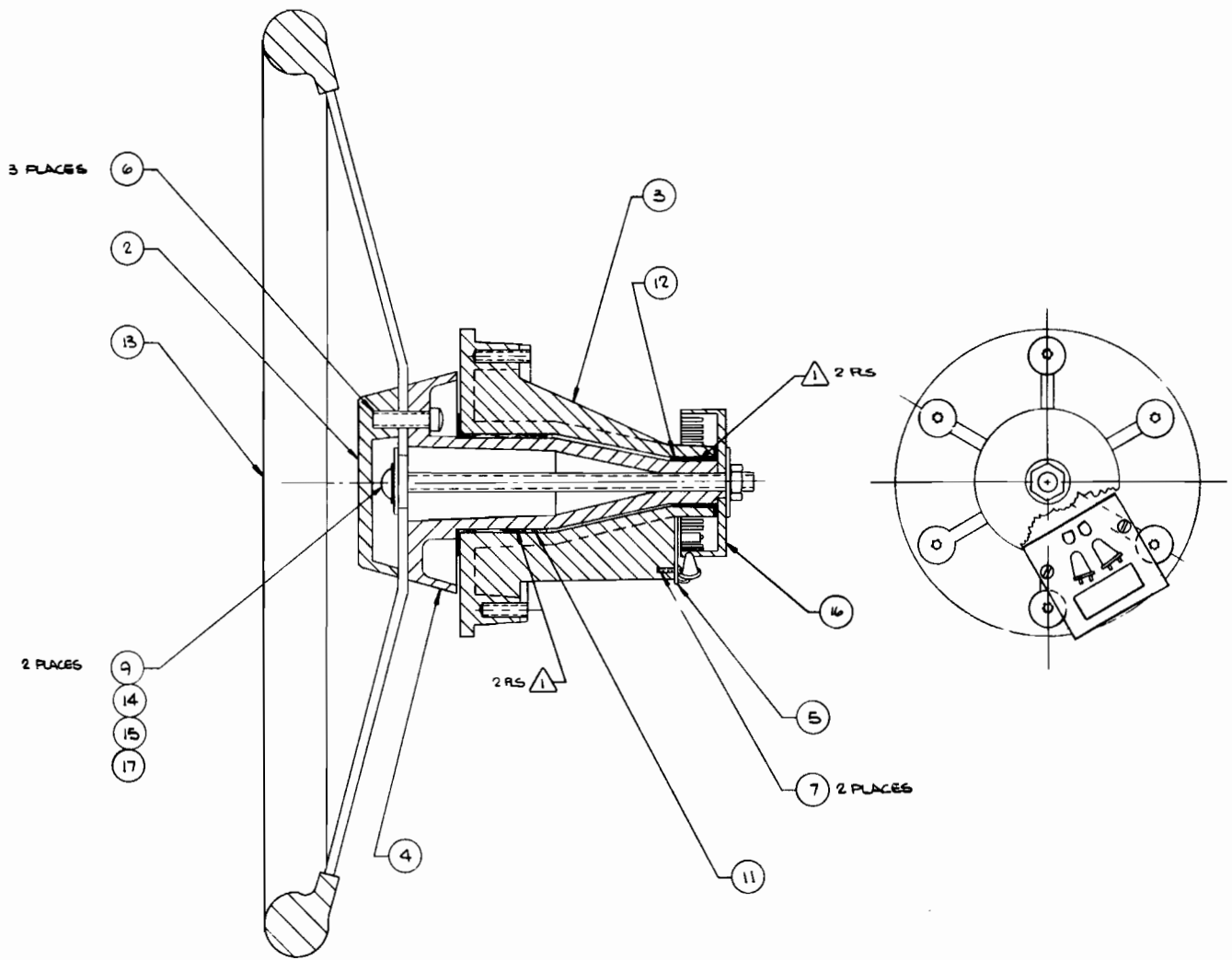

List of Materials

| Item | Part No. | Description |
|------|----------|-------------------------|
| 1. | 00598 | Steering Wheel Assembly |
| 2. | 000599 | Cover |
| 3. | 000605 | Housing |
| 4. | 000606 | Shaft |
| 5. | 000607 | PCB Assembly |
| 6. | 75804 | Screw, 1/4-20 x 3/4 |
| 7. | 75424 | Screw, 2 x 1/4 |
| 8. | | |
| 9. | 75409 | Washer, Fender, 1/4 |
| 10. | | |
| 11. | 83236 | Bearing |
| 12. | 83242 | Bearing |
| 13. | 83243 | Steering Wheel |
| 14. | 75221 | Nut, 1/4-20, Nylon Lock |
| 15. | 75198 | Screw, 1/4-20 x 5 |
| 16. | 000616 | Light Hub |
| 17. | 75189 | Washer, 1/4, Starlock |
| 18. | 83268 | Silicone Grease, 5 |

- NOTES:
1. APPLY LIGHT FILM OF SILICONE GREASE 5 COMPOUND (OR EQUIV.) ON AREAS INDICATED. (ITEM 18)
2. VENDOR PART NO. 3201-3803

Figure 9. Steering Wheel Assembly

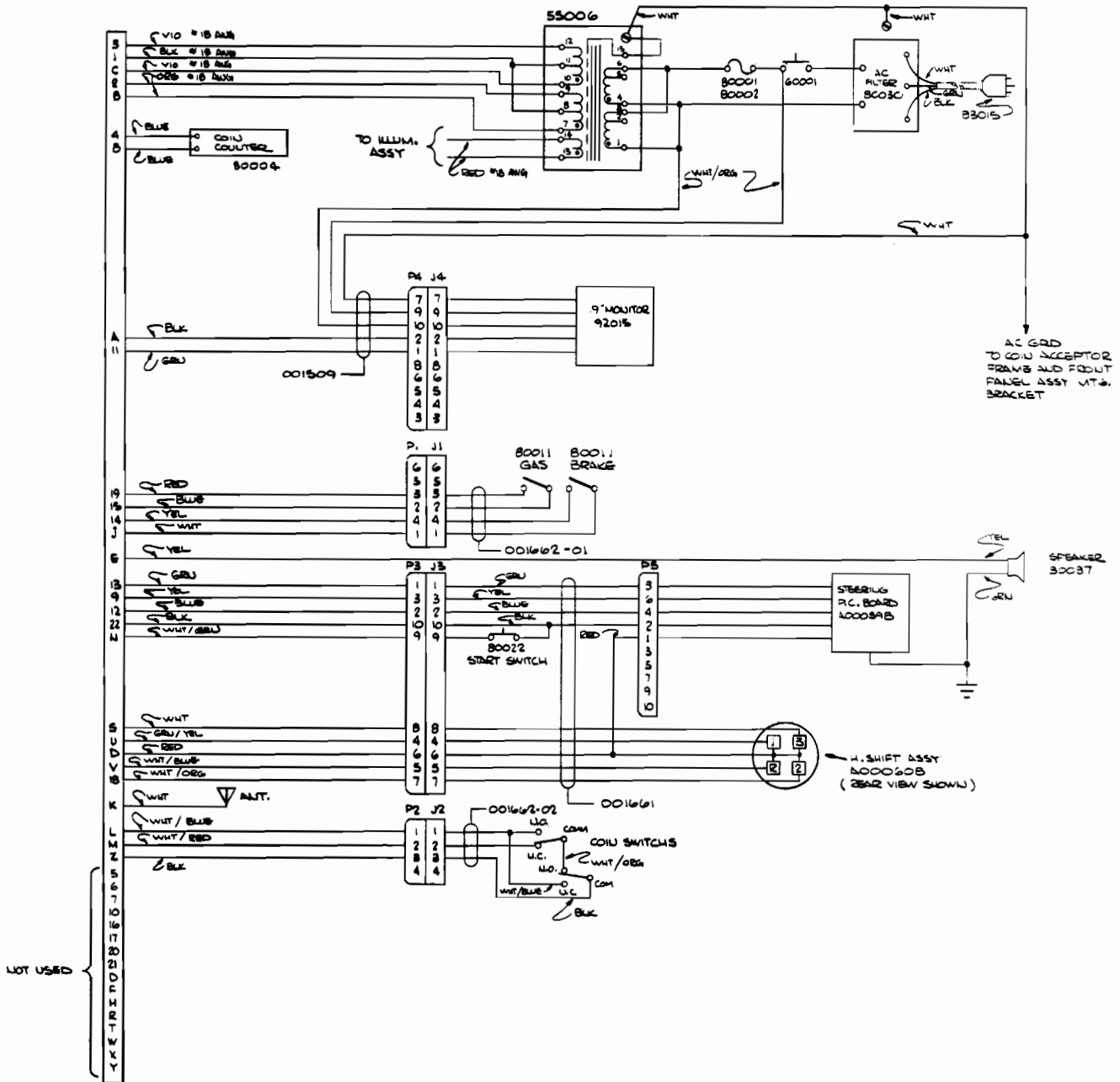

Figure 10. Wiring Diagram

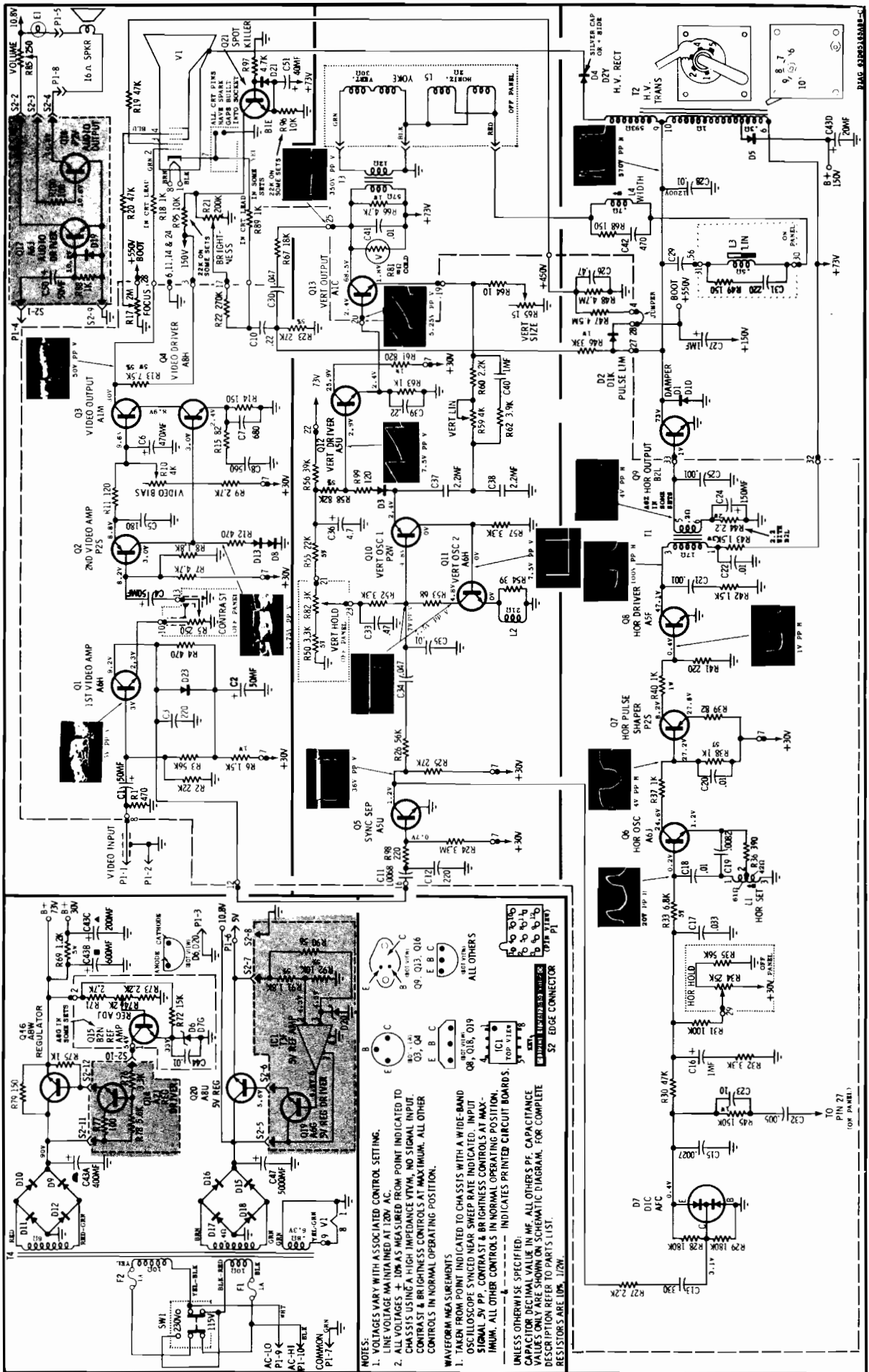
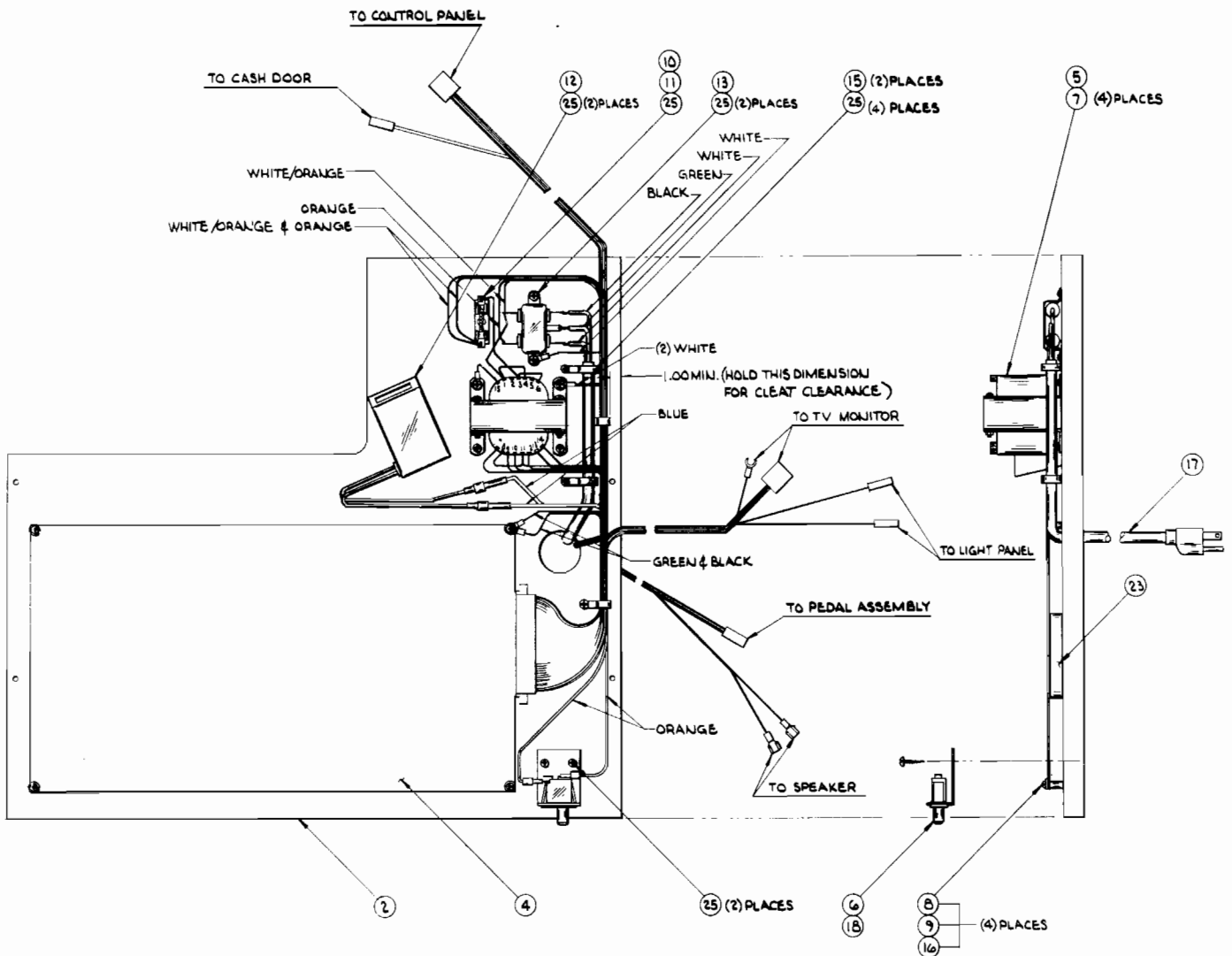

Figure 11. TV Monitor Schematic Diagram



List of Materials

| Item | Part No. | Qty. | Description |
|------|---------------|------|---------------------------------|
| 1 | A001506 | Ref | Electronics Tray Assembly |
| 2 | 001568 | 1 | Tray Electronics |
| 3 | 00622 | 1 | Cover, Transformer |
| 4 | A00872F | 1 | PCB Assembly, Computer Rev. F |
| 5 | 55006 | 1 | Transformer |
| 6 | 60001 | 1 | AC Power Interlock Switch |
| 7 | 75158 | 21 | Screw, 8x3/4" Rd Hd, Phil., SMS |
| 8 | 72-6620/75211 | 4 | Screw, 61/4" Pan Hd, Phil., SMS |
| 9 | 75-0165/75102 | 4 | Washer, Flat 6 |
| 10 | 80001 | 1 | Fuse Holder |
| 11 | 80002 | 1 | Fuse, 1 amp, Slow Blo |
| 12 | 80004 | 1 | Counter |

| | | | |
|----|----------------|---|---------------------------|
| 13 | 80030 | 1 | Filter, Power Line |
| 14 | | | |
| 15 | 83042 | 4 | Cable Clamp |
| 16 | 74-3608/83013 | 4 | Spacer, 1/2", 6 |
| 17 | 83015 | 1 | Power Cord, 8 |
| 18 | 83097/000268 | 1 | Brkt., Switch Mtg. |
| 19 | 51-11833/77035 | 2 | Wire, 18 guage, Orange |
| 20 | 51-11822/77037 | 2 | Wire, 18 guage, Red |
| 21 | 79-08322/80054 | 2 | Terminal, Push on (3/16") |
| 22 | 001509 | 1 | Harness |
| 23 | 001141 | 1 | Form, Disc. Polyurethane |
| 24 | 000871 | 1 | Label |

Figure 12. Electronics Tray Assembly

