

Online Radio & Electronics Course

Reading 39

Ron Bertrand VK2DQ
<http://www.radioelectronicschool.com>

TEST EQUIPMENT AND MEASUREMENTS

SSB MEASUREMENTS

Why use a two-tone test signal?

The two-tone test signal is the standard modulating signal used when conducting tests on an SSB transmitter. If an SSB transmitter is voice modulated then the output waveform, as seen on an oscilloscope, would be totally unpredictable and totally dependent on the voice characteristics of the operator. The peak power measured in this way would vary from one operator to the next. The two-tone signal overcomes this problem by providing a standard test source which produces a predictable wave shape on an oscilloscope, enabling tests to be repeated.

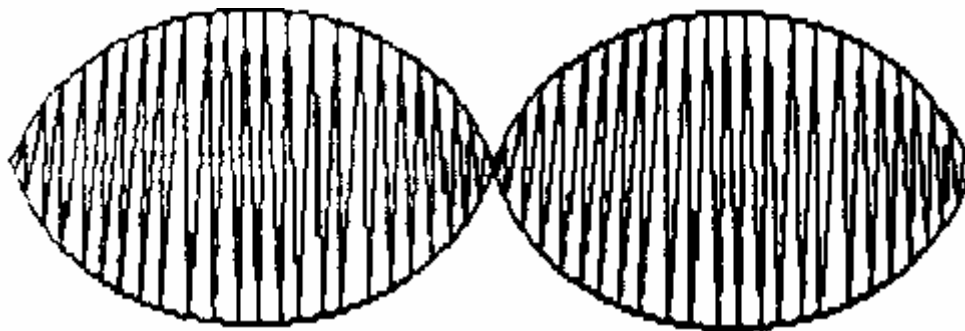

Figure 1.

You should be able to identify the waveform in figure 1 as an SSB signal modulated with the two-tone test signal and displayed on an oscilloscope.

In addition, the two-tone signal enables the linearity of an SSB transmitter to be checked. It is highly unlikely that the typical amateur station will ever perform a linearity check on an SSB transmitter, since this requires a spectrum analyser. However, the examiner does expect the candidate to know that the test signal is used for linearity testing.

If the two-tone signal is used to modulate an SSB transmitter and the output of the transmitter checked with a spectrum analyser, then only those radio frequencies representing the two tones should be present if the transmitter is perfectly linear. In practice other signals will be present in the output - these will be the result of the two discrete signals mixing due to some non-linearity within the transmitter. The level of these mixing products is shown on specifications as intermodulation distortion products (IMD). The frequencies of the two-tone signal are not important provided they are not harmonically related and fit within the audio passband of the transmitter under test.

MEASUREMENT OF THE ENVELOPE POWER

To measure the peak envelope power (PEP) of an SSB transmitter:

1. Connect a dummy load to the transmitter output.
2. Connect a modulation monitor (usually an oscilloscope).
3. Connect an output level indicating device (an RF voltmeter/ammeter or average/peak power meter).
4. Apply a two-tone test signal to the microphone input.
5. Adjust the two-tone signal or microphone gain for 100% modulation.
6. Read output level.

If a peak voltmeter or ammeter is used, then the RMS value must be found by multiplying the result by 0.707. The average power can then be found from:

$$P_{\text{average}} = E^2 / R$$

The peak envelope power, using the two-tone test, is the average power multiplied by two. In other words:

$$\text{PEP} = 2 \times E_{\text{rms}}^2 / R_{\text{load}}$$

Keep in mind that the PEP of an SSB transmitter **must** be measured at 100% modulation. This creates problems for amateur operators who may reduce the microphone gain to control their power output while on SSB. It may be necessary to reduce power output because a large external linear amplifier might transmit over the legal limit at 100% modulation. Sounds fine (that is, reducing the mic gain to reduce the power out), however it is not possible to measure the power at the reduced modulation percentage. This method is therefore unacceptable to the ACA. This potentially awkward situation does not usually come to a head unless serious interference problems exist and then the operator may be directed to make modifications to the transmitter in order to comply strictly with regulations.

CATHODE RAY TUBES

Figure 2 shows a cross-section of a cathode-ray tube (CRT) showing all the important parts.

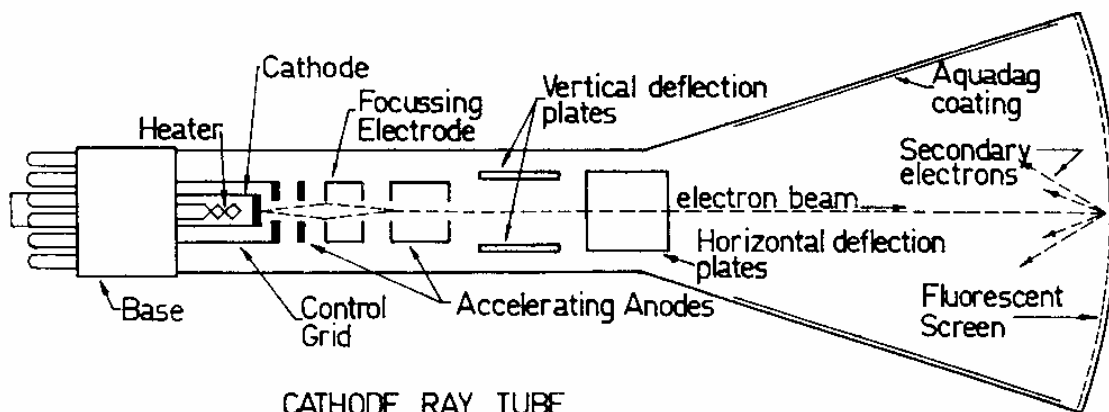
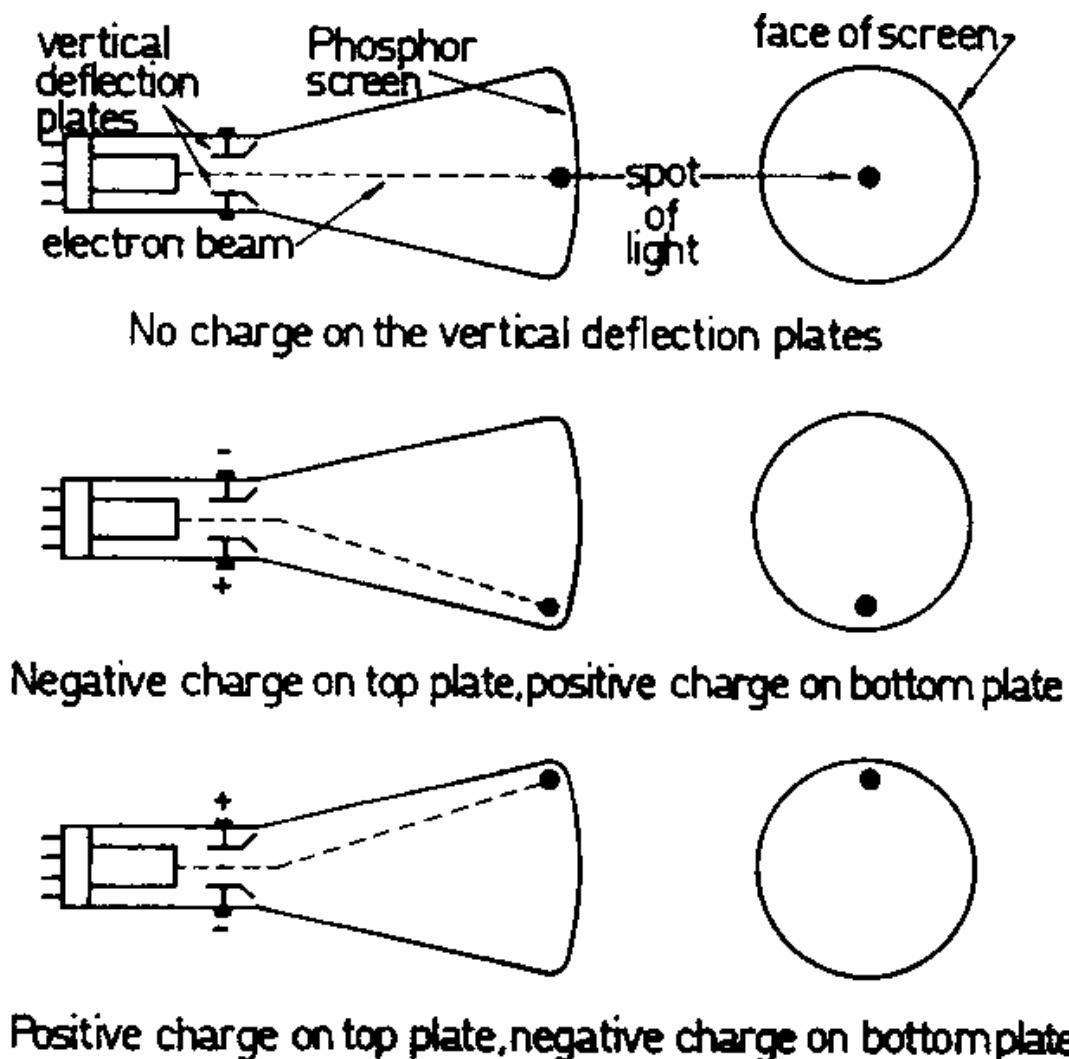

Figure 2.

The CRT is in many respects similar to the ordinary electron tube. The differences arise from the different uses which are made of the electron beam that is attracted to the anode. A controlled beam of electrons was originally called a cathode ray, hence the name "cathode-ray tube". Like the ordinary electron tube, there is a heater and cathode to create a space charge, an anode to attract electrons, and a control grid to adjust the flow of these electrons. The anode current of a CRT is quite small, typically no more than 1 milliamper. The anode voltage is typically between 10 and 25 kV. The anodes, as shown in figure 2, have a small hole in the end to allow the electron beam to pass through to the fluorescent screen.

It may seem that the electron beam should be attracted to the anode instead of passing through it. The reason this doesn't happen is that throughout most of its journey the electron beam is surrounded by the anode, so there is **no difference of potential sideways across the tube to deflect the beam**. The flanged sides of the CRT are coated with a conductive Aquadag coating which is at the same potential as the anode. This serves to keep the beam on track and drain off electrons once they have struck the screen and emitted a photon of light.

Figure 3 - How the deflection plates control the displayed image



The focusing electrode enables the beam to be concentrated into a narrow beam by creating an electrostatic lens (magnetic fields are used in TV receivers). Two pairs of deflection plates enable the beam to be deflected to any position on the screen by the

electric field created between them from an applied deflection voltage (refer to figure 3).

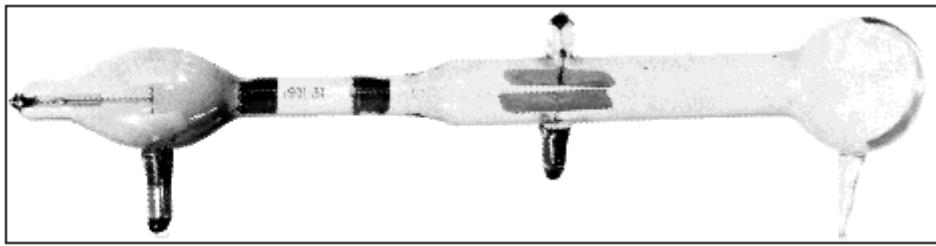

Figure 4.

Figure 4 shows a picture of the first cathode-ray tube made by Thompson.

The process by which photons of light are emitted when an electron strikes the atoms within the phosphorus coating is called fluorescence. However, there is also another effect called phosphorescence, which has a continuance of the glow after the collision. This characteristic, together with the persistence of human vision, enables waveforms and TV images to be displayed without flicker on a cathode-ray tube.

Note: Aquadag is a trademark of Acheson Industries, Inc. It consists of a conductive coating of graphite.

THE OSCILLOSCOPE

The purpose of an oscilloscope is to provide a graphical representation of a voltage(s) and how it varies over time.

A block diagram of a free running cathode-ray oscilloscope is shown in figure 5. A sawtooth (sweep) oscillator is connected to the horizontal deflection plates via a sweep amplifier and a phase inverter.

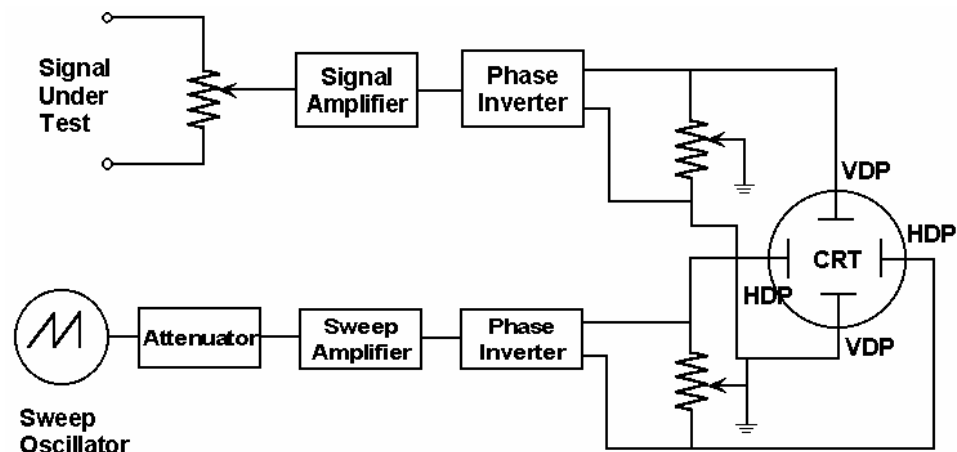

OSCILLOSCOPE

Figure 5.

If the frequency of the sawtooth is set to 1 Hz then the electron beam will be swept across the screen once each second. The sole purpose of the sweep oscillator is to continuously move the electron beam horizontally across the screen.

A sawtooth waveform from the sweep oscillator is connected to the horizontal deflection plates. This sweeps the beam across the screen at the desired rate, and the almost **vertical time decay of the sawtooth** prevents a **retrace line** from appearing. The signal

under test is connected to the vertical deflection plates.

The sweep oscillator control on the front panel will be marked in time per division. The display is usually divided into ten divisions on each axis, each division equal to one centimetre.

If a household mains signal of 240 volts and 50 Hz is applied to the vertical deflection plates, and the sweep oscillator frequency adjusted so that the electron beam moves entirely across the screen in a time equal to the period of the sine wave, then a full single sine wave would be displayed.

The signal under test is connected to the vertical deflection plates via a signal amplifier and a phase inverter. The phase inverter modifies a varying DC input signal to AC, permitting an AC signal to be positioned correctly on the centre graticule (marking) on the display. That is, positive above the centre graticule and negative below.

The brightness of the trace is controlled by the potential on the control grid of the CRT. (This is a typical exam question).

The 'X' or horizontal axis represents time and the 'Y' or vertical axis the amplitude of the signal under test.

SOME REVISION

Multipliers - Shunts - Voltmeters - Ammeters

Multipliers are very high value resistances connected in series with a moving coil meter to enable the meter to measure high voltages. The excess voltage that would otherwise overload the meter is dropped across the multiplier.

Shunts are low value resistances connected in parallel with a moving coil meter to enable the meter to measure high currents. Excess current is bypassed around the meter by the low resistance shunt.

Voltmeters must have a very high value of resistance relative to the circuit in which they are placed.

Ammeters must have a very low resistance relative to the circuit in which they are placed.

To measure the potential difference (voltage) across a resistance the voltmeter must be connected in parallel with the resistance. If the voltmeter resistance is not at least 10 times higher than the value of the resistance across which it is placed, then the resistance of the meter will substantially alter the resistance in that part of the circuit, and cause a false or inaccurate reading.

An ammeter measures current flow in much the same way that a liquid flow meter measures the flow of water or fuel through a pipe. If the flow meter does not have a low opposition to the flow of fluid through it, then inserting the flow meter into a line will reduce the flow of liquid and make accurate measurement impossible. Likewise, if an ammeter is to be connected in series with a conductor to measure the current flow through it, then its resistance must be so low as to have negligible effect on the circuit.

THE SENSITIVITY OF THE VOLTMETER

The total resistance of a voltmeter can be determined by multiplying the sensitivity in ohms-per-volt by the voltage scale to which the moving coil meter is switched.

If a voltmeter has a sensitivity of 10,000 ohms-per-volt and is switched to the 10 volt scale then the total resistance of the meter will be $10 \times 10,000 = 100$ kilohms. If this meter was used to measure the voltage across a 10,000 ohm resistor or less, then the meter would have a negligible effect on the circuit conditions and acceptable accuracy would be obtained. However, imagine if this voltmeter was connected across a 500,000 ohm resistor. The meter resistance, being only 100,000 ohms, would totally upset conditions in that part of the circuit and an unacceptable voltage reading would be obtained.

A common mistake made by many students is that the resistance of the meter is determined by the voltage reading multiplied by the sensitivity - this of course is not correct. The total resistance of the meter is the sensitivity in ohms-per-volt multiplied by the voltage range or scale to which the meter is switched.

Electronic digital multimeters are not given an ohms-per-volt rating. The input of these meters is constant regardless of the range to which they are switched. Their input resistance is typically in the order of 10 megohms or more.

CALCULATING THE SENSITIVITY IN OHMS-PER-VOLT

The voltage drop across a 100 microampere meter movement is 100 millivolts at full-scale deflection. Calculate the sensitivity of the meter in ohms-per-volt?

This question has more information than is needed to arrive at the answer. The sensitivity of a moving coil meter is directly related to the current required to deflect the meter movement to full scale, in this case 100 microamperes. The sensitivity is easily found by finding the reciprocal of the full-scale deflection current:

$$\text{Sensitivity of the meter} = 1 / (100 \times 10^{-6}) = 10,000 \text{ ohms-per-volt.}$$

CALCULATING A MULTIPLIER RESISTANCE

Calculate the value of a multiplier resistance needed to enable a moving coil meter with a full scale deflection (FSD) of 50 microamperes and an internal resistance of 2000 ohms, to be used as a voltmeter to measure up to 10 volts (refer to figure 6).

The sensitivity of the meter is $1 / (50 \times 10^{-6}) = 20,000$ ohms-per-volt. Since the voltmeter is to be used to measure 10 volts FSD, then the total resistance of the voltmeter is $10 \times 20,000 = 200,000$ ohms. Subtracting the meter movement's resistance from the total resistance leaves the value of the multiplier resistance as **198,000 ohms**. Putting this method into an equation we get:

Figure 6.

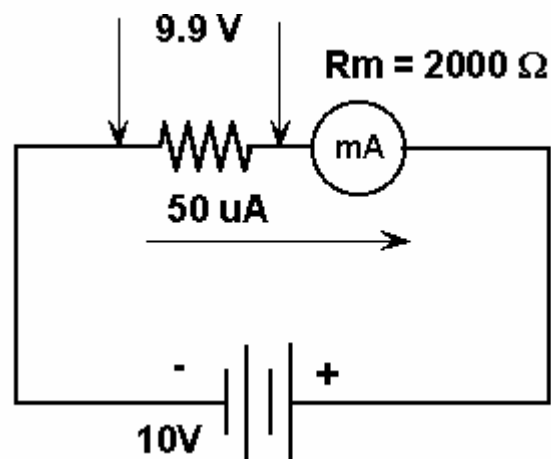

$$R_{\text{multiplier}} = (1 / I_{\text{FSD}}) \times \text{range} - R_{\text{meter}}$$

Where: I_{FSD} = full-scale deflection current, and
 R_{meter} = meter resistance.

The above method can be proved by using Ohm's law to resolve the same problem. When 10 volts is applied to the meter, the circuit current must be 50 microamperes for full-scale deflection. The voltage across the meter can be calculated from:

$$E = IR = 50 \times 10^{-6} \times 2000 = 0.1 \text{ volts.}$$

The remaining 9.9 volts must be across the multiplier. Since the current through the multiplier and the voltage across the multiplier are both known, the multiplier resistance can be calculated from:

$$R = E / I = 9.9 / (50 \times 10^{-6}) = 198,000 \text{ ohms.}$$

THE RF PROBE

To enable a DC voltmeter to measure RF voltages, an RF probe must be connected to the voltmeter.

The schematic diagram of an RF probe is shown in figure 7.

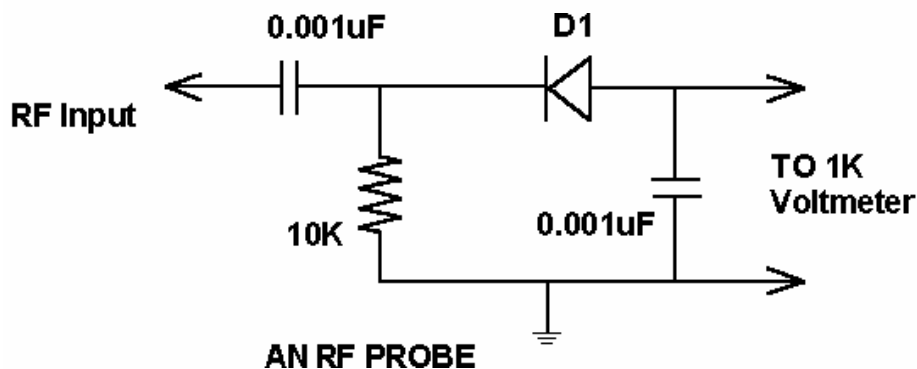

Figure 7.

You may be expected to identify this circuit in an examination. The RF probe consists of a **simple half wave rectifier and filter**. For the best frequency response a point contact diode should be used (IN82A or similar). The probe must be housed in a shielded case and the lead to the meter must be shielded.

By measuring the voltage developed across a known load (say a dummy load of 50 ohms), the output power can then be calculated from $P = E^2/R$, where E is the RMS voltage and P the average power. Power levels as low as a few milliwatts at frequencies up to several hundred megahertz can be measured using an RF probe.

ACCURATE MEASUREMENT OF RF CURRENT

The most accurate power meters are those that determine the power output of a transmitter by converting a portion of the transmitter's output energy directly to heat. These types of meters measure the true RMS power regardless of the wave shape, and also keep their calibration over a wide frequency range.

Meters which fit this category are the thermocouple ammeter, calorimeters, and photometric meters. The most popular type for RF measurement is the thermocouple. A meter of this type may cost from \$800 upwards, but provides accurate power measurements into the microwave range.

THE VSWR METER

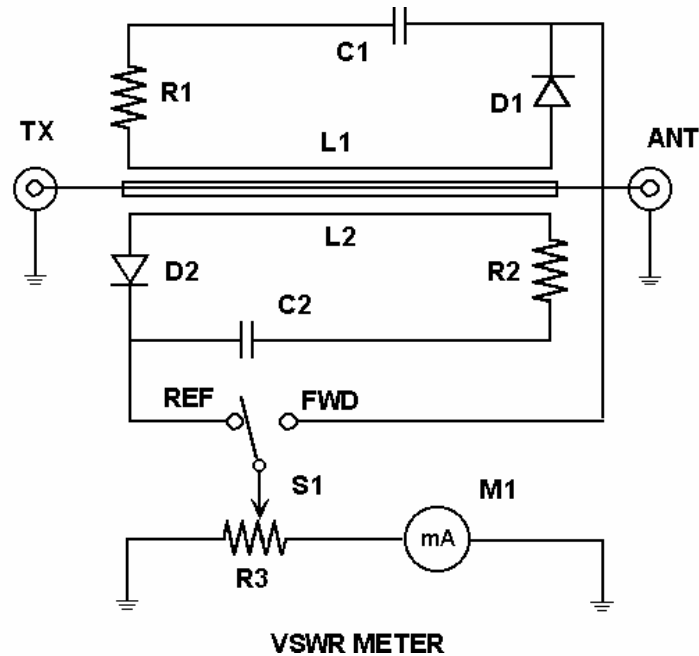

The following description of the operation of a VSWR meter is given for completeness sake, and is not required for examination purposes. However, you may be required to identify the schematic diagram.

Refer to figure 8. A forward moving RF wave travelling through the VSWR meter from the transmitter to antenna will induce small forward moving waves into L1 and L2.

The forward wave induced into L2 will arrive at R2 and be totally dissipated, since R2 is equal to the characteristic impedance formed by the centre conductor in the VSWR meter and L2. However, the forward moving wave induced into L1 will be rectified by D1 and this rectified current will produce a DC voltage across C1. The level of the voltage across C1 is directly proportional to the forward voltage.

If the transmission line is not terminated in the correct impedance then a reflected wave will be present which will travel through the VSWR meter from antenna to transmitter and induce currents into L1 and L2.

The reflected wave induced into L1 is absorbed by R1, but the reflected wave induced into L2 is rectified by D2, and a DC voltage is developed across C2 which is directly proportional to the voltage of the reflected wave.

So it can be seen that the upper circuit consisting of L1, C1 and D1, is only responsive to forward waves while the lower circuit consisting of L2, C2 and D2, will only respond to reflected waves.

The switch S1 enables the operator to switch between the forward and reflected voltage readings. Meter M1 will read the voltage across C1 and C2, being the forward and reflected voltages respectively.

Though this meter could be calibrated to measure forward and reflected voltage, it is more commonly used to only measure VSWR, and the operator is frequently unaware that it is in fact a forward and reflected voltage meter.

For VSWR measurements the operator switches S1 to the forward position and, while transmitting, adjusts R3 for full-scale deflection on M1. The forward voltage is now referenced to full scale. S1 is then switched to the reflected position and the pointer on M1 will directly read the coefficient of reflection (K). If the forward voltage and reflected voltage are equal (open or short circuit termination), then the reflected reading will be full scale, indicating a K of 1. If there is no reflected voltage (perfectly matched system) then there will be no deflection of M1, indicating a K of zero. If 50% of the forward voltage wave is reflected then M1 will indicate half scale deflection or a K of 0.5.

Therefore, you see, the most common type of VSWR meter is really measuring coefficient of reflection. However, there is a simple relationship between K and VSWR:

$$\text{VSWR} = (1+K) / (1-K)$$

For example, suppose the reflected voltage came to half scale, or K=0.5. What is the VSWR?

$$\text{VSWR} = (1 + 0.5) / (1 - 0.5) = 3$$

This explains why all (non-amplified) VSWR meters have '3' calibrated at centre scale. If you want to make your VSWR meter more useful just calibrate the scale from 0 to 1 using rub on lettering and it will now double as a coefficient of reflection meter.

REFLECTOMETER

In the schematic diagram of the VSWR meter (figure 8), the section of the circuit consisting of the two pickup inductors (L1 and L2) and their associated terminating resistors, is in fact a dual reflectometer since it has two loops for simultaneous measurement of forward and reflected voltage.

A reflectometer can be made or purchased as a stand-alone test device. To use a reflectometer, a 'level indicating device' such as a power meter or RF voltmeter must be added. Some instruments have a moving coil meter calibrated in watts connected to each port of a dual reflectometer.

THE DIP OSCILLATOR

A dip oscillator is just a portable hand held oscillator. The operating principle works as follows. The dip oscillator is set to oscillate at a known frequency, say 14 MHz. Now suppose the dip oscillator is moved close to a circuit resonant on 14 MHz. Remember when we talked about bringing a vibrating tuning fork close to another non-vibrating tuning fork on the same resonant frequency? Energy is transferred from one tuning fork to the other. A dip oscillator running on 14 MHz and brought close to tuned circuit on 14 MHz will result in RF power being transferred from the dip oscillator to the resonant circuit under

test. The resonant circuit under test could be an antenna or a literal LC circuit. So, the dip oscillator then, is ideal for finding the resonant frequency of an antenna or an LC circuit. Energy is not transferred from the dip oscillator to an external circuit unless the external circuit is mutually resonant with the dip oscillator. The dip oscillator has a meter - a current dip on the meter indicates mutual resonance.

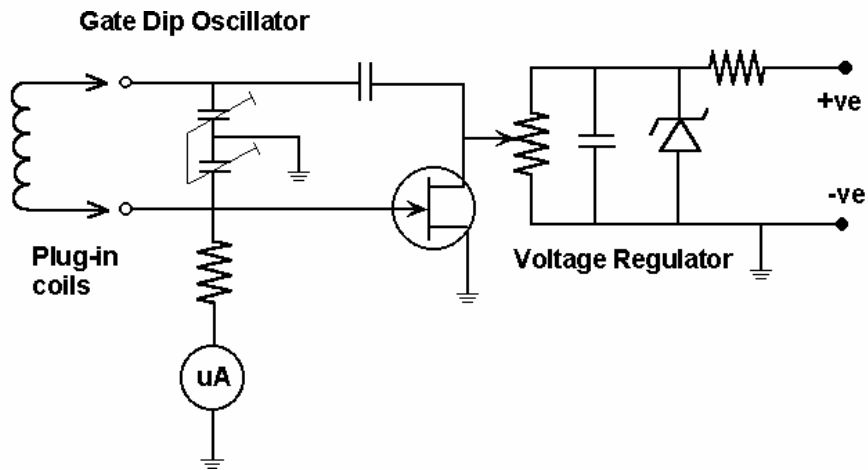

Figure 9.

Refer to figure 9. When the circuit is oscillating, an RF voltage will appear across the resistor between the gate and ground. Because of the rectifying action of the gate-source junction, a DC current will flow through this resistor and indicate on the meter. In a free running oscillator the gate voltage is high, and therefore the current is high. When the coil of the resonant circuit is coupled to an external resonant circuit, power will be transferred when the two circuits are mutually resonant. This will be indicated by a dip in the gate current meter. The calibrated dial will indicate the frequency of the external circuit.

A dip oscillator only measures resonant frequency. However, if one component of a resonant circuit is known (L or C) then the resonant frequency can be measured and the value of the unknown component worked out mathematically.

I have often seen an exam question which tests for the function of a dip oscillator. One of the answer options might be to 'measure capacitance' or 'measure inductance'. Don't get caught here, a dip oscillator only measures resonant frequency. Capacitance or inductance may be calculated from knowing the resonant frequency, but the dip oscillator does not measure L or C directly.



Figure 10.

Figure 10 shows a practical dip oscillator, with its schematic shown in figure 11.

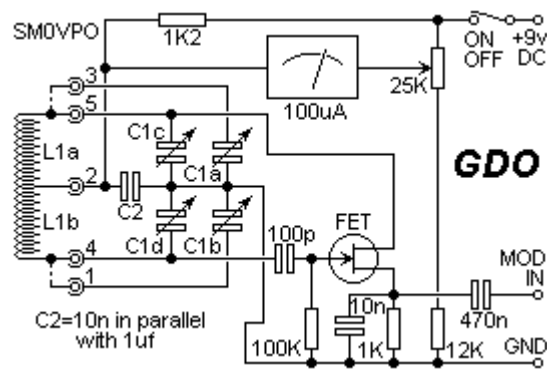

Figure 11.

USING THE DIP OSCILLATOR AS A WAVEMETER

A wavemeter is just a simple selective receiver. By reducing the drain voltage to zero, oscillation stops and the gate and the source act as a diode to indicate energy is being picked up from an external 'live' resonant circuit, and so the dip oscillator is used here as an absorption wave meter. Such a wave meter would be useful for checking harmonic radiation from a transmitter. The oscillator can also be picked up on a receiver enabling it to be used as a simple signal generator.

THE NOISE BRIDGE

A noise bridge contains a noise source, and an LC bridge. It is used to determine the resistive and reactive parts of an unknown impedance.

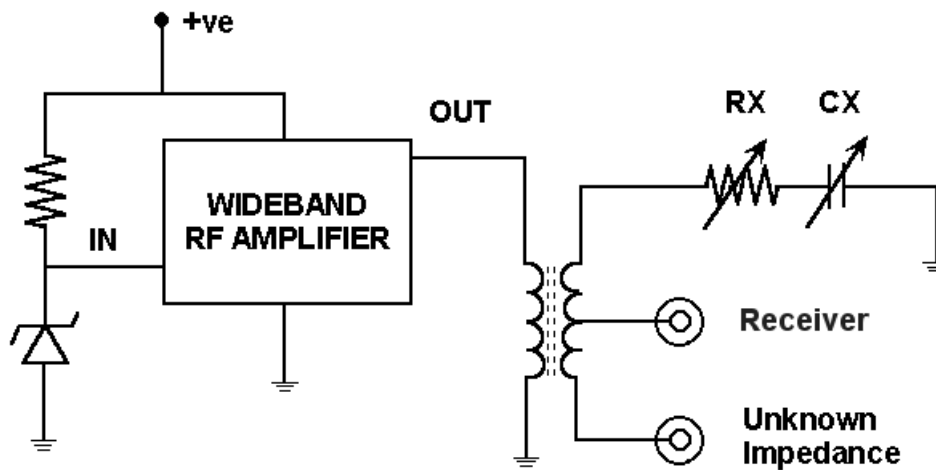

Figure 12 – Noise Bridge.

The noise source is typically a reverse biased zener diode, which produces usable noise voltage output from about a few hundred kilohertz to around 100 MHz. The noise is amplified by a wide-band amplifier and then applied to a bridge network. An unknown impedance (usually an antenna) is connected to one arm of the bridge and the bridge adjusted for balance. A receiver is connected to the bridge to act as an RF indicator for balance. There are two balance controls, 'R' and 'X', which are calibrated for the resistive and reactive components of the unknown impedance respectively.

You simply connect the noise bridge to an antenna (for example), and a receiver, Then adjust the 'R' and 'X' knobs until the noise 'nulls' (when the bridge is balanced). You then read the antennas impedance as indicated on the 'R' and 'X' knobs.

If you use a noise bridge to measure the input impedance of an antenna you are trying to build or tune, then any reactance present would indicate that the antenna is not resonant.

A noise bridge is one of the most useful items of test gear to have in an amateur radio shack - second perhaps (in my opinion) to a multimeter.

If you really want to understand antennas and transmission lines then a noise bridge is highly recommended. They are very easy to build and calibrate - a very inexpensive project. Perhaps the only disadvantage of a noise bridge is the upper frequency limit of around 100 MHz.

A practical circuit for a noise bridge is shown in figure 13.

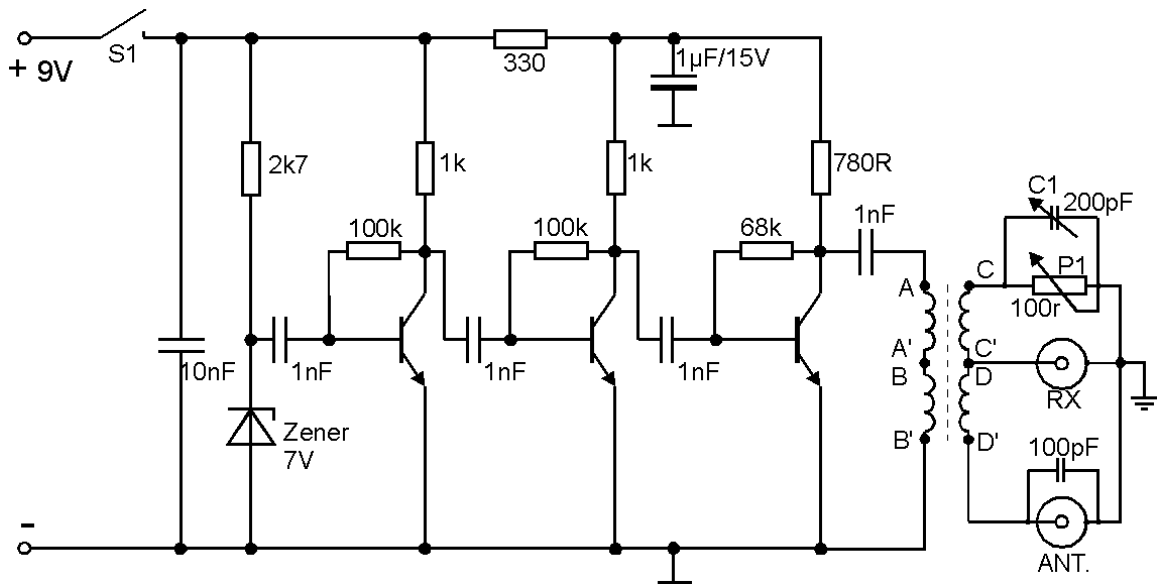

Figure 13.

The noise bridge is a great project to build, or such a bridge can be purchased for under \$150.

End of Reading 39
 Last revision: July 2002
 Copyright © 1999-2002 Ron Bertrand
 E-mail: manager@radioelectronicschool.com
<http://www.radioelectronicschool.com>
 Free for non-commercial use with permission