

Table of Contents

Sheet 1A	You Are Here
Sheet 1B	Dig Dug Upright Wiring Diagram (038294-01 A)
Sheet 2A	Dig Dug Cocktail Wiring Diagram (038377-01 A)
Sheet 2B	Dig Dug Cabaret Wiring Diagram (038391-01 A)
Sheet 3A	Color Raster-Scan Power Supply Wiring Diagram (037669-01 C) Regulator/Audio II PCB Schematic Diagram (035435-01 F)
Sheet 3B	Upright and Cabaret Coin Door Wiring Diagram (037542-01 B) Cocktail Coin Acceptor Wiring Diagram (036597-01 C) Utility Panel Wiring Diagram (038004-01 A) Fluorescent Light and Speaker Wiring Diagram (035833-01 A)

Game PCB Schematics (038156-xx B), Sheets 3A—9A

Sheet 4A	Power Input, Clock, NMI, Watchdog, and Memory Map
Sheet 4B	1st Priority CPU, 2nd Priority CPU
Sheet 5A	3rd Priority CPU, Address Decoder
Sheet 5B	Switch Inputs, Coin Door and Control Panel Outputs
Sheet 6A	Audio
Sheet 6B	Sync Generator
Sheet 7A	Playfield Generator
Sheet 7B	Motion Object RAM, Motion Object Address Generator, Decoder and Match Line Flag
Sheet 8A	Motion Object Generator
Sheet 8B	Video Output, Video Color Controller
Sheet 9A	High-Score Table
Sheet 9B	Electrohome 19-Inch Color Raster-Scan Video Display Schematic Diagram

NOTE
This staple temporarily holds the
schematic package together. Re-
move the staple before using the
schematics.

Schematic Package Supplement to

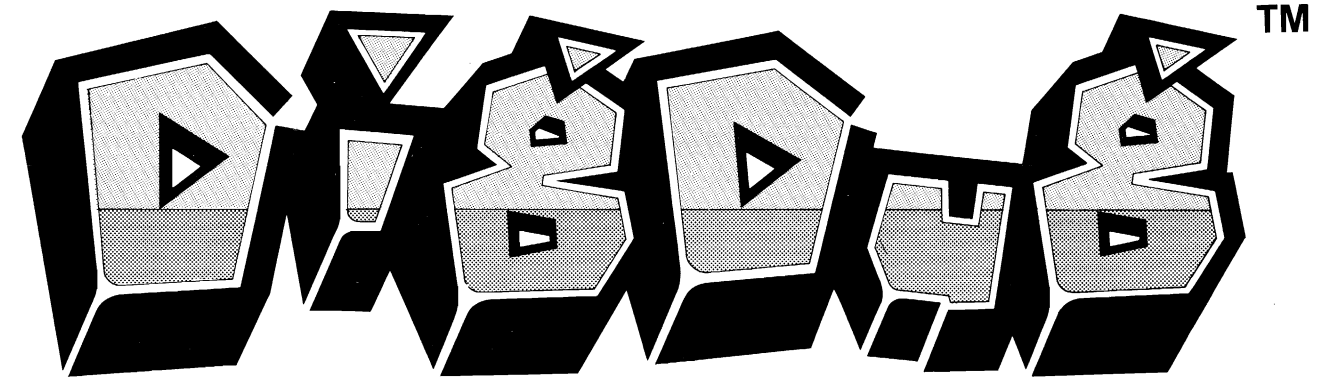

Operation, Maintenance and Service Manual



© ATARI INC. 1982

Upright Wiring Diagram

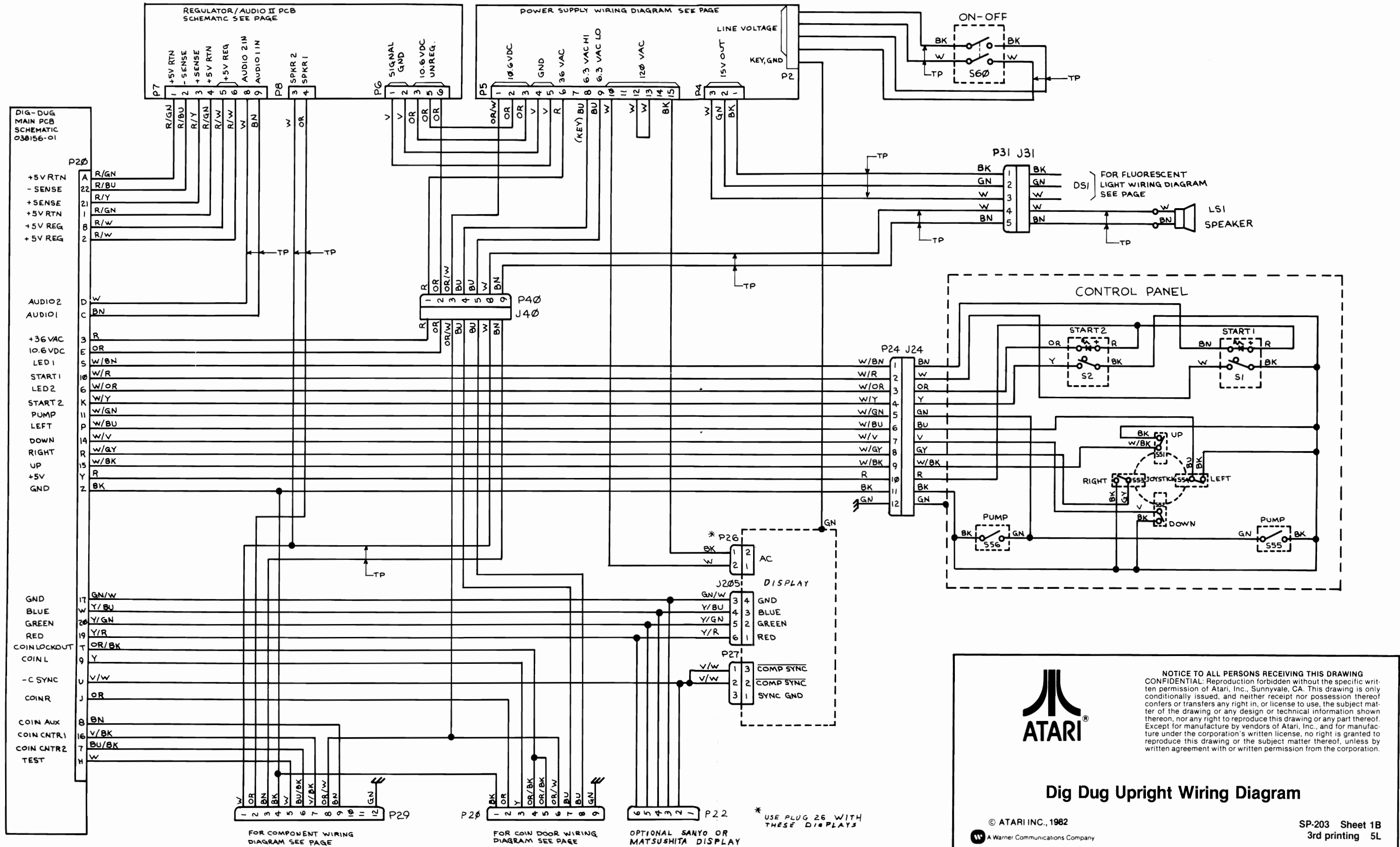

NOTICE TO ALL PERSONS RECEIVING THIS DRAWING
 CONFIDENTIAL: Reproduction forbidden without the specific written permission of Atari, Inc., Sunnyvale, CA. This drawing is only conditionally issued, and neither receipt nor possession thereof confers or transfers any right in, or license to use, the subject matter of the drawing or any design or technical information shown thereon, nor any right to reproduce this drawing or any part thereof. Except for manufacture by vendors of Atari, Inc., and for manufacture under the corporation's written license, no right is granted to reproduce this drawing or the subject matter thereof, unless by written agreement with or written permission from the corporation.

Dig Dug Upright Wiring Diagram

© ATARI INC., 1982
 A Warner Communications Company

SP-203 Sheet 1B
 3rd printing 5L

Cocktail Wiring Diagram

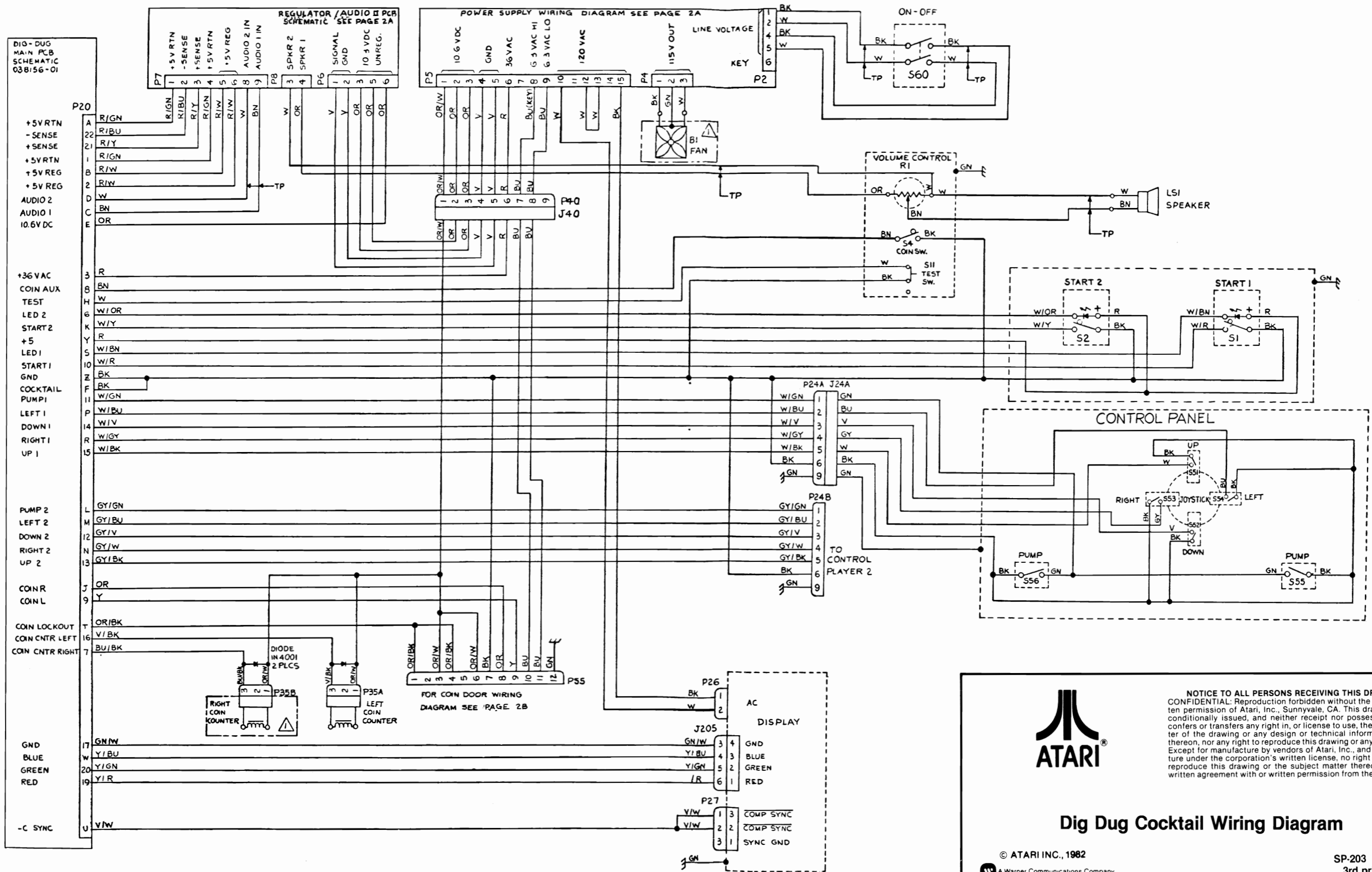



ATARI

NOTICE TO ALL PERSONS RECEIVING THIS DRAWING
 CONFIDENTIAL: Reproduction forbidden without the specific written permission of Atari, Inc., Sunnyvale, CA. This drawing is only conditionally issued, and neither receipt nor possession thereof confers or transfers any right in, or license to use, the subject matter of the drawing or any design or technical information shown thereon, nor any right to reproduce this drawing or any part thereof. Except for manufacture by vendors of Atari, Inc., and for manufacture under the corporation's written license, no right is granted to reproduce this drawing or the subject matter thereof, unless by written agreement with or written permission from the corporation.

Dig Dug Cocktail Wiring Diagram

© ATARI INC., 1982
 A Warner Communications Company

SP-203 Sheet 2A
 3rd printing 5L

Cabaret Wiring Diagram

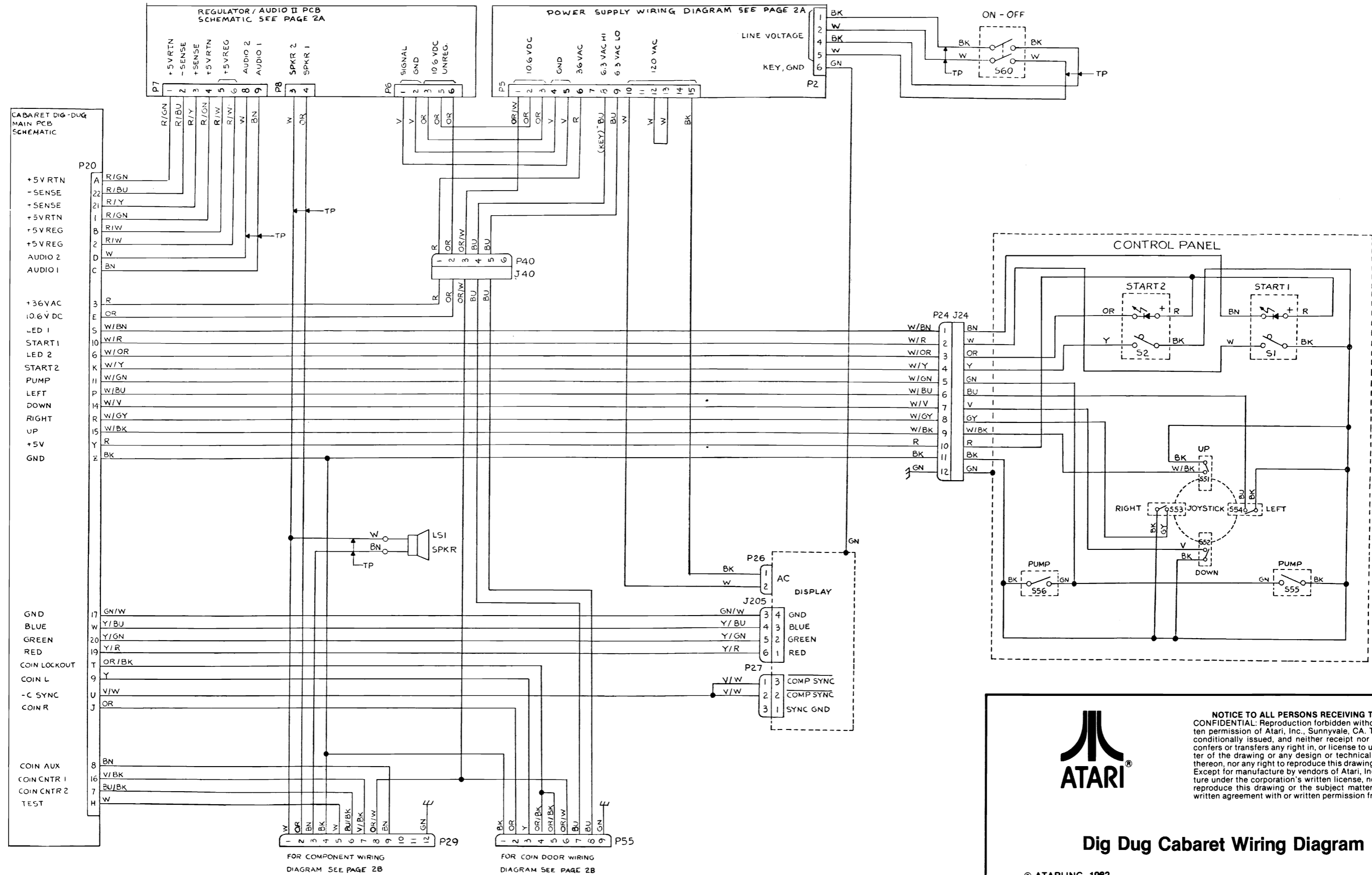

NOTICE TO ALL PERSONS RECEIVING THIS DRAWING
 CONFIDENTIAL: Reproduction forbidden without the specific written permission of Atari, Inc., Sunnyvale, CA. This drawing is only conditionally issued, and neither receipt nor possession thereof confers or transfers any right in, or license to use, the subject matter of the drawing or any design or technical information shown thereon, nor any right to reproduce this drawing or any part thereof. Except for manufacture by vendors of Atari, Inc., and for manufacture under the corporation's written license, no right is granted to reproduce this drawing or the subject matter thereof, unless by written agreement with or written permission from the corporation.

Dig Dug Cabaret Wiring Diagram

© ATARI INC., 1982
 A Warner Communications Company

SP-203 Sheet 2B
 3rd printing 5L

Color Raster Power Supply Wiring Diagram

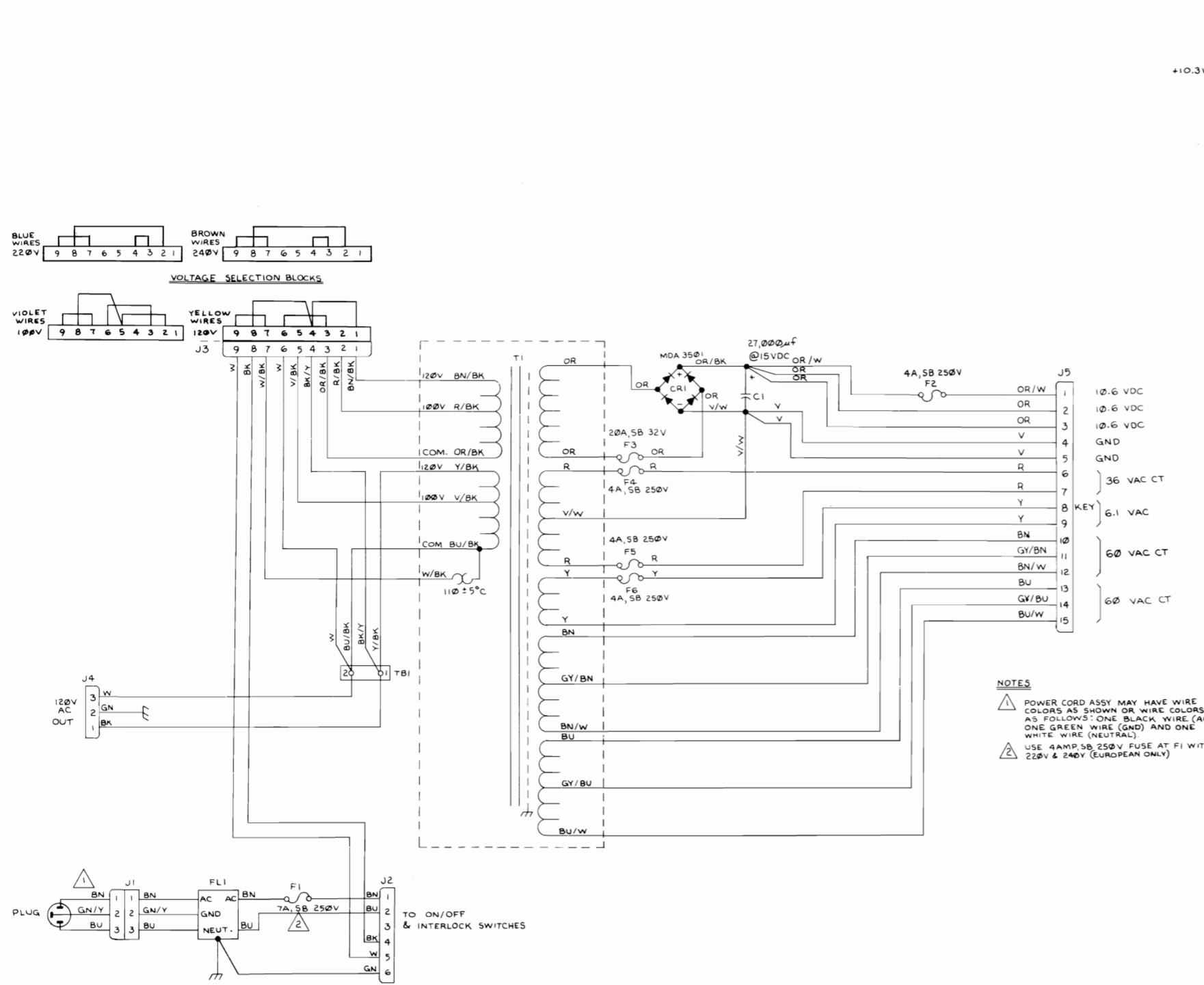

Regulator/Audio II PCB Schematic Diagram

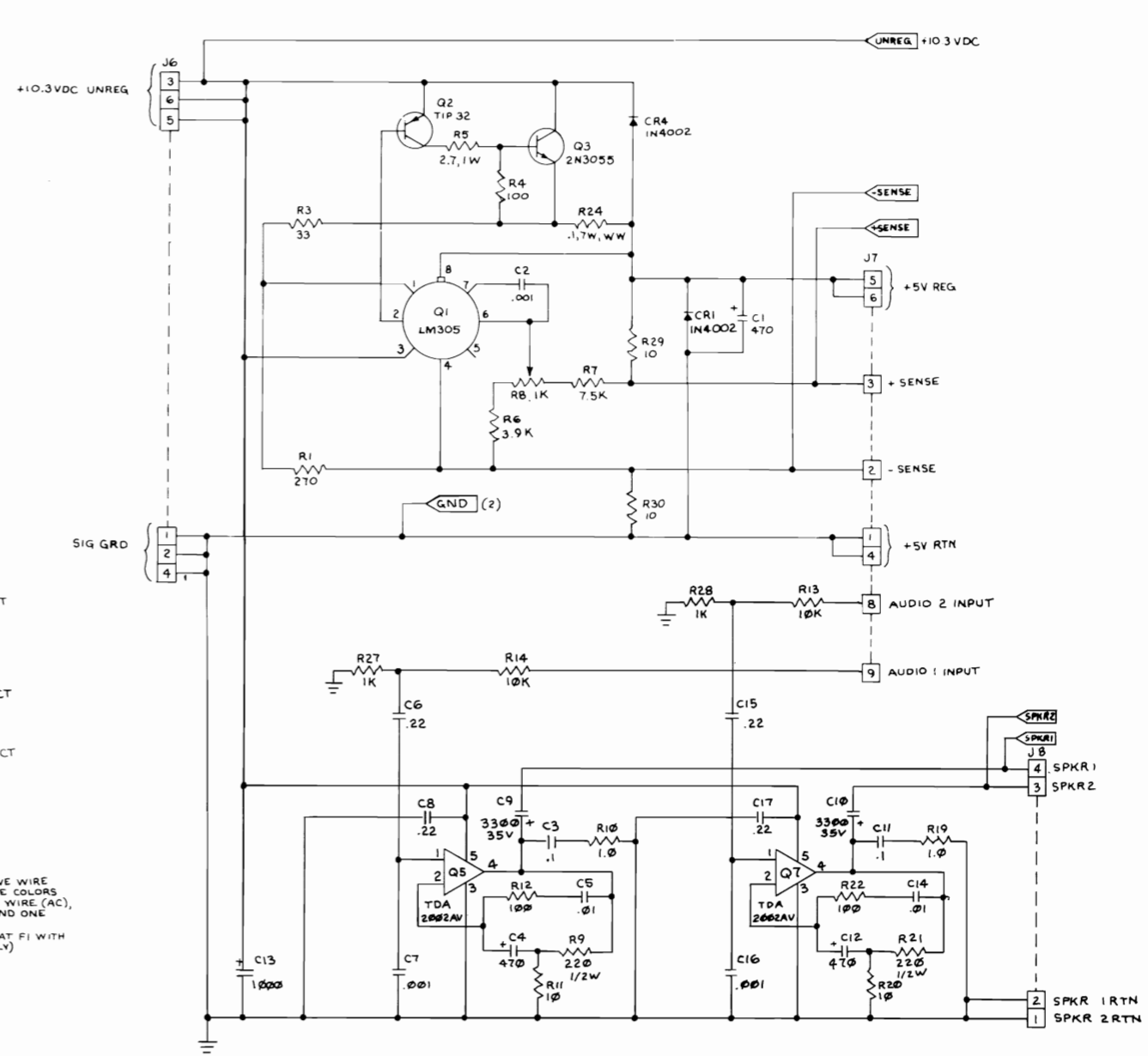



ATARI

NOTICE TO ALL PERSONS RECEIVING THIS DRAWING
 CONFIDENTIAL: Reproduction forbidden without the specific written permission of Atari, Inc., Sunnyvale, CA. This drawing is only conditionally issued, and neither receipt nor possession thereof confers or transfers any right in, or license to use, the subject matter of the drawing or any design or technical information shown thereon, nor any right to reproduce this drawing or any part thereof. Except for manufacture by vendors of Atari, Inc., and for manufacture under the corporation's written license, no right is granted to reproduce this drawing or the subject matter thereof, unless by written agreement with or written permission from the corporation.

Dig Dug Power Supply and Reg./Audio II PCB

© ATARI INC., 1982
 A Warner Communications Company

SP-203 Sheet 3A
 3rd printing 5L

Utility Panel Wiring Diagram

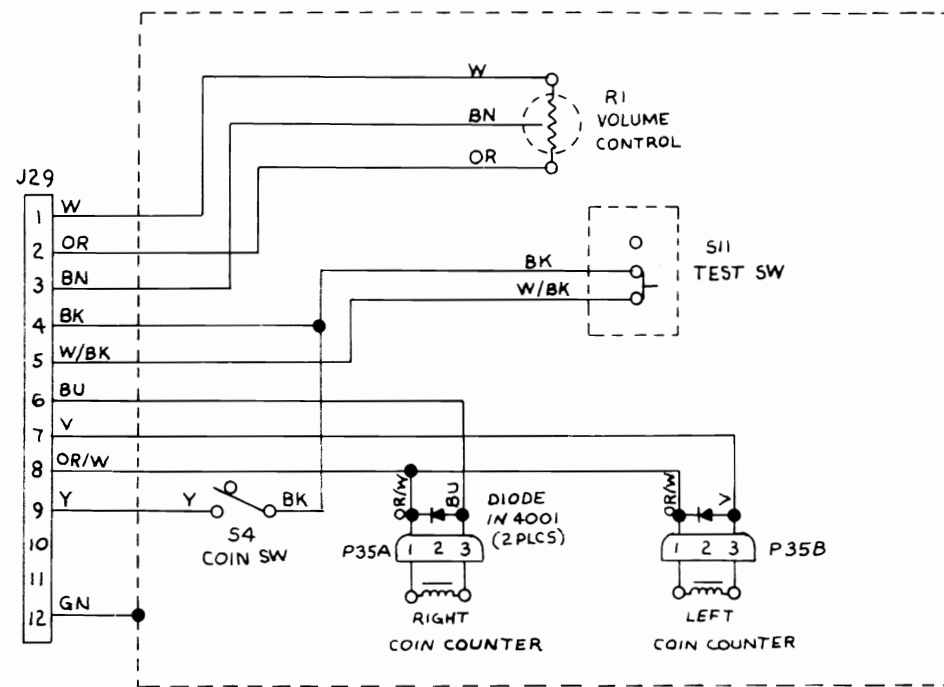

Upright and Cabaret Coin Door Wiring Diagram

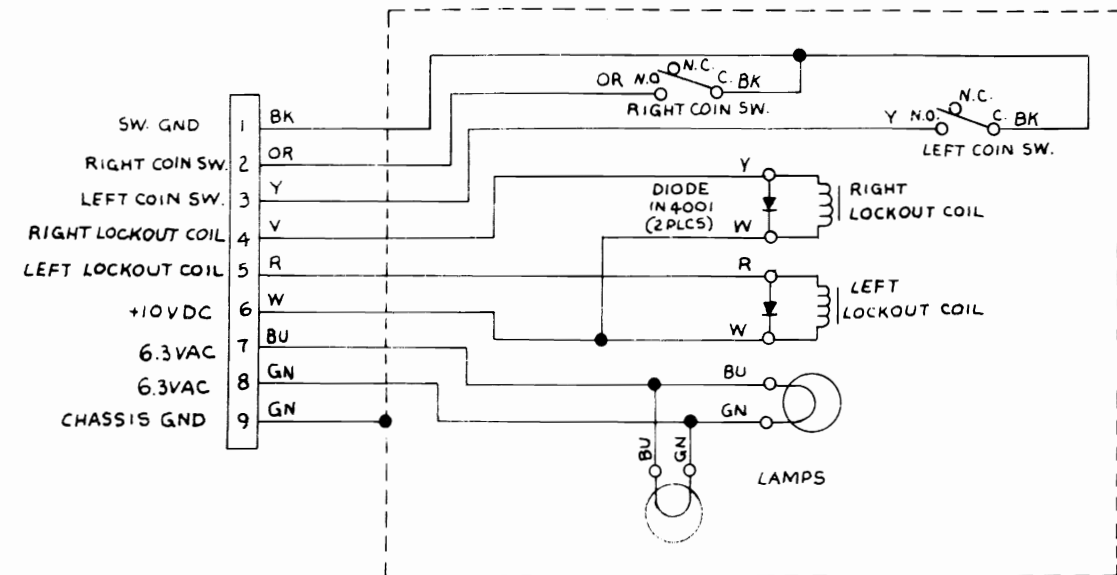

Fluorescent Light and Speaker Wiring Diagram

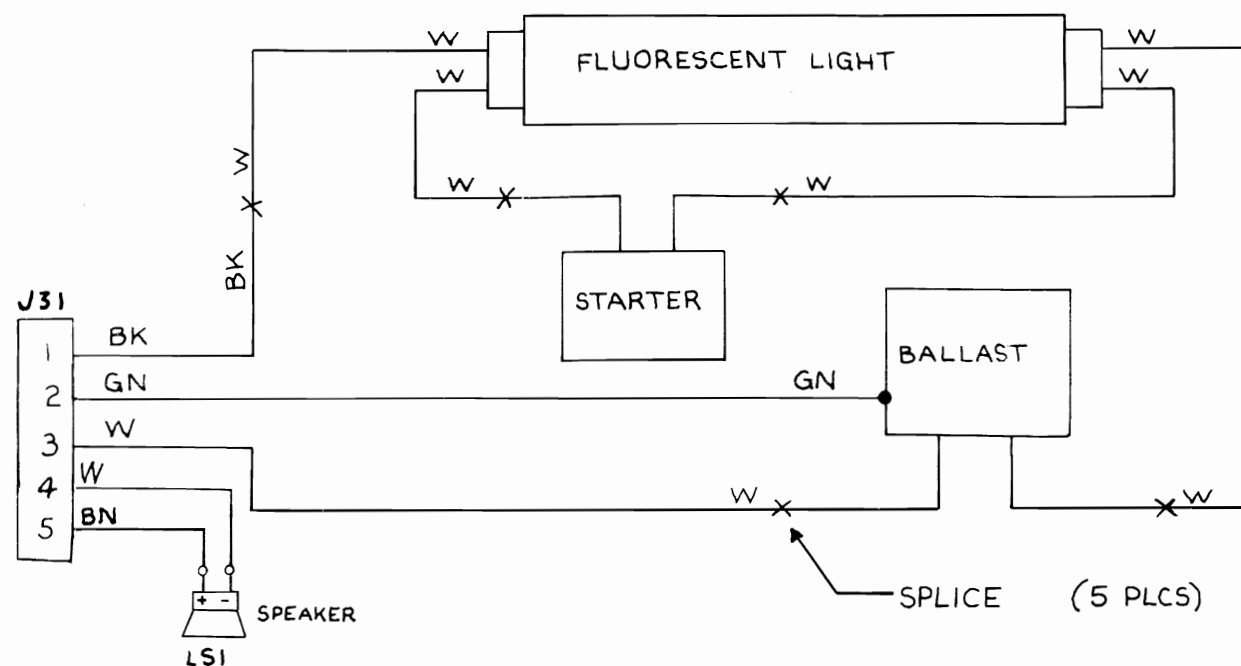

Cocktail Coin Acceptor Wiring Diagram

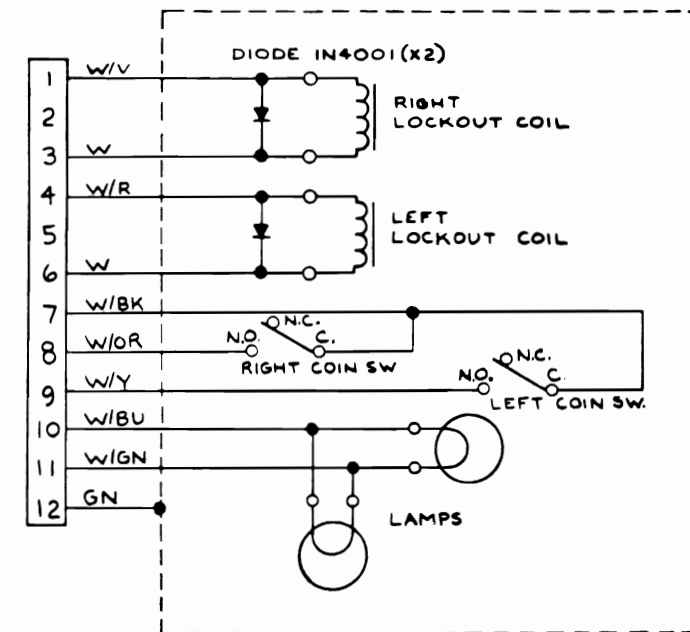

NOTICE TO ALL PERSONS RECEIVING THIS DRAWING
 CONFIDENTIAL: Reproduction forbidden without the specific written permission of Atari, Inc., Sunnyvale, CA. This drawing is only conditionally issued, and neither receipt nor possession thereof confers or transfers any right in, or license to use, the subject matter of the drawing or any design or technical information shown thereon, nor any right to reproduce this drawing or any part thereof. Except for manufacture by vendors of Atari, Inc., and for manufacture under the corporation's written license, no right is granted to reproduce this drawing or the subject matter thereof, unless by written agreement with or written permission from the corporation.

Dig Dug Game Wiring Interfaces

CPU PCB Power Input, Clock, NMI, and Watchdog

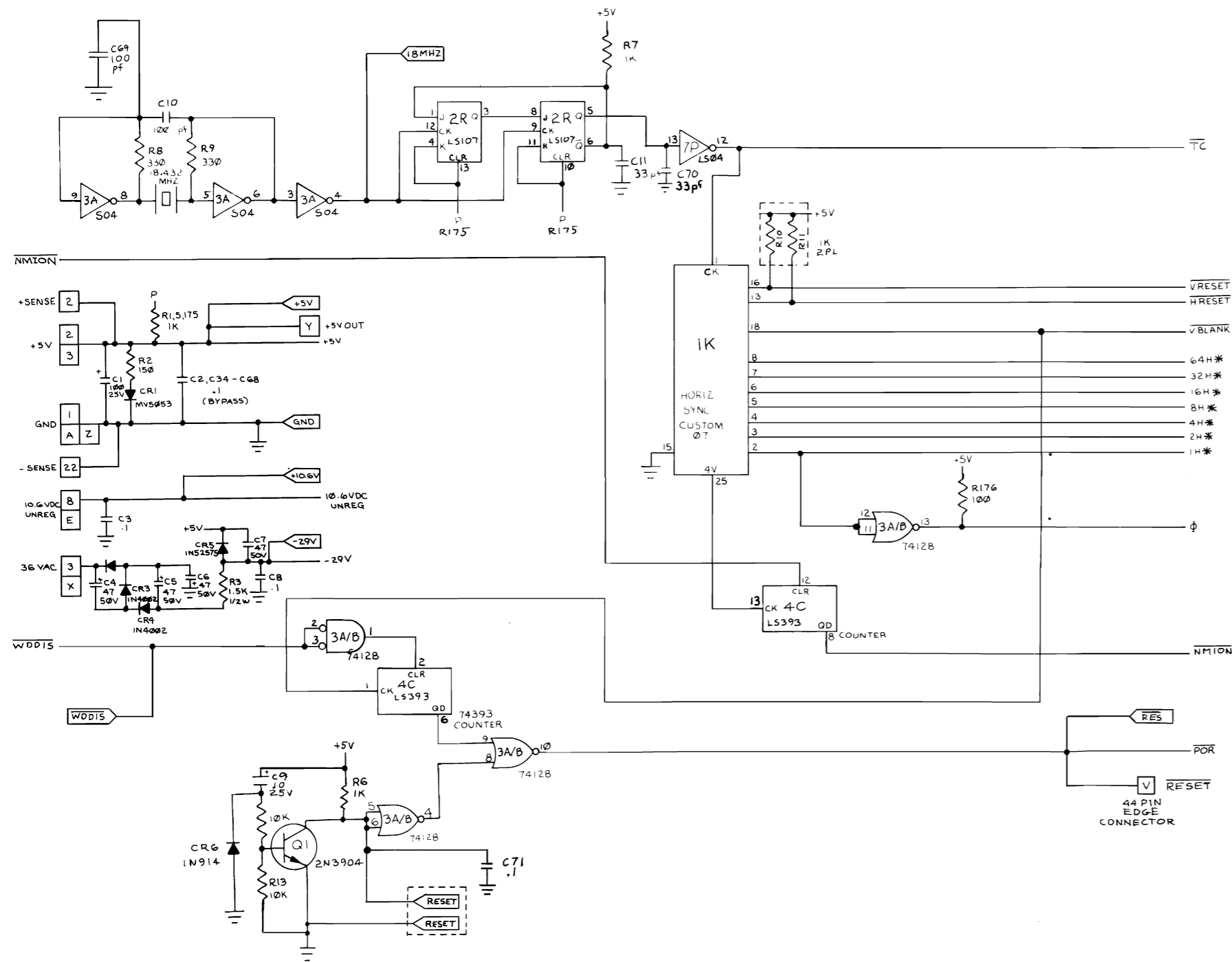

MEMORY MAP

HEXA-DECIMAL ADDRESS	R/W	DATA								FUNCTION
		D7	D6	D5	D4	D3	D2	D1	D0	
0000-3FFF	R	D	D	D	D	D	D	D	D	1st Priority Z80 CPU ROM (16K)
0000-1FFF	R	D	D	D	D	D	D	D	D	2nd Priority Z80 CPU ROM (8K)
0000-0FFF	R	D	D	D	D	D	D	D	D	3rd Priority Z80 CPU ROM (4K)
6800-680F	W					D	D	D	D	Audio Control
6810-681F	W					D	D	D	D	Audio Control
6820	W								D	0 = Reset IRQ1 (Latched)
6821	W								D	0 = Reset IRQ2 (Latched)
6822	W								D	0 = Enable NMI3 (Latched)
6823	W								D	0 = Reset 2nd and 3rd Z80 CPUs (Latched)
6825	W								D	Custom Chip 53 Mode Control (Latched)
6826	W								D	Custom Chip 53 Mode Control (Latched)
6827	W								D	Custom Chip 53 Mode Control (Latched)
6830	W									Watchdog Reset
7000	R/W	D	D	D	D	D	D	D	D	Custom Chip 06—Data
7100	R/W	D	D	D	D	D	D	D	D	Custom Chip 06—Command
8000-87FF	R/W	D	D	D	D	D	D	D	D	2K Playfield RAM
8B80-8BFF	R/W	D	D	D	D	D	D	D	D	1K Motion RAM (PIC, COLOR)
9380-93FF	R/W	D	D	D	D	D	D	D	D	1K Motion RAM (VPOS, HPOS)
9B80-9BFF	R/W	D	D	D	D	D	D	D	D	1K Motion RAM (FLIP)
A000	W								D	Playfield Select (Latched)
A001	W								D	Playfield Select (Latched)
A002	W								D	Alphanumeric Color Select (Latched)
A003	W								D	Playfield Enable (Latched)
A004	W								D	Playfield Color Select (Latched)
A005	W								D	Playfield Color Select (Latched)
A007	W								D	Flip Video
B800-B83F	W	D	D	D	D	D	D	D	D	Write EAROM Address and Data
B800	R	D	D	D	D	D	D	D	D	Read EAROM Data
B840	W					D	D	D	D	Write EAROM Control



NOTICE TO ALL PERSONS RECEIVING THIS DRAWING
 CONFIDENTIAL: Reproduction forbidden without the specific written permission of Atari, Inc., Sunnyvale, CA. This drawing is only conditionally issued, and neither receipt nor possession thereof confers or transfers any right in, or license to use, the subject matter of the drawing or any design or technical information shown thereon, nor any right to reproduce this drawing or any part thereof. Except for manufacture by vendors of Atari, Inc., and for manufacture under the corporation's written license, no right is granted to reproduce this drawing or the subject matter thereof, unless by written agreement with or written permission from the corporation.

Dig Dug CPU PCB Schematic Diagram

© ATARI INC., 1982
 A Warner Communications Company

SP-203 Sheet 4A
 3rd printing 5L

1st Priority CPU

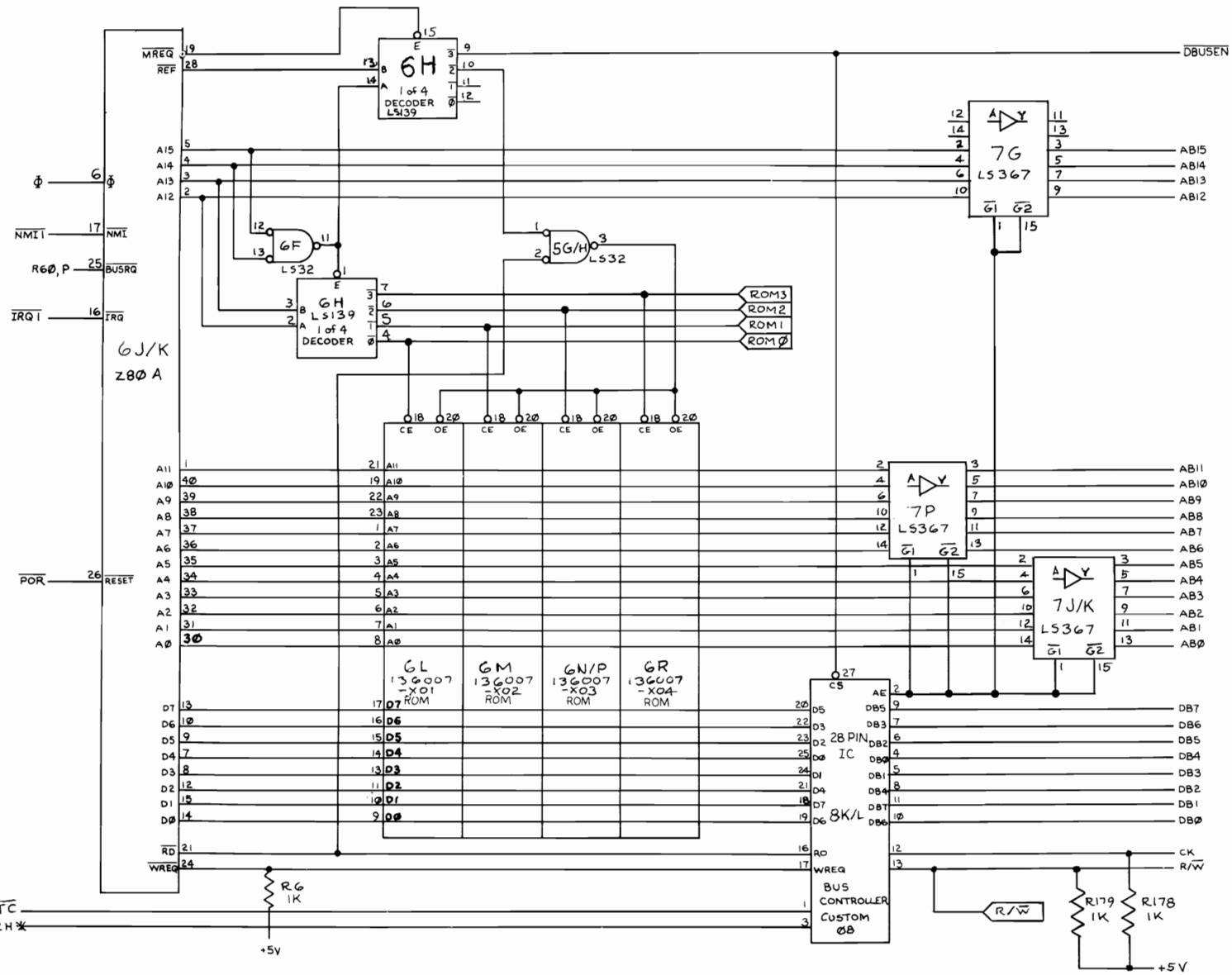

2nd Priority CPU

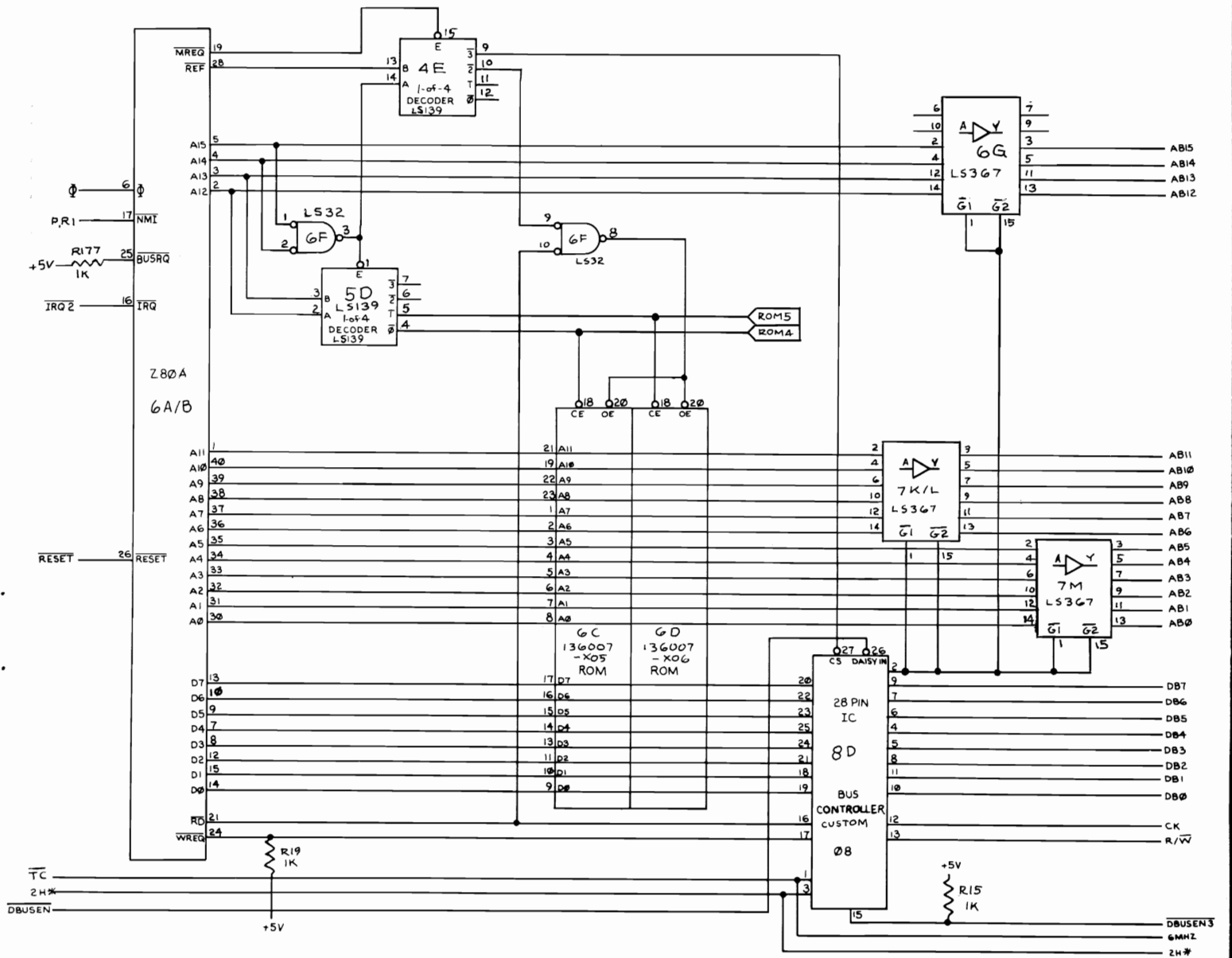

NOTICE TO ALL PERSONS RECEIVING THIS DRAWING
 CONFIDENTIAL: Reproduction forbidden without the specific written permission of Atari, Inc., Sunnyvale, CA. This drawing is only conditionally issued, and neither receipt nor possession thereof confers or transfers any right in, or license to use, the subject matter of the drawing or any design or technical information shown thereon, nor any right to reproduce this drawing or any part thereof. Except for manufacture by vendors of Atari, Inc., and for manufacture under the corporation's written license, no right is granted to reproduce this drawing or the subject matter thereof, unless by written agreement with or written permission from the corporation.

Dig Dug Game PCB Schematic Diagram

© ATARI INC., 1982
 A Warner Communications Company

SP-203 Sheet 4B
 3rd printing 5L

3rd Priority CPU

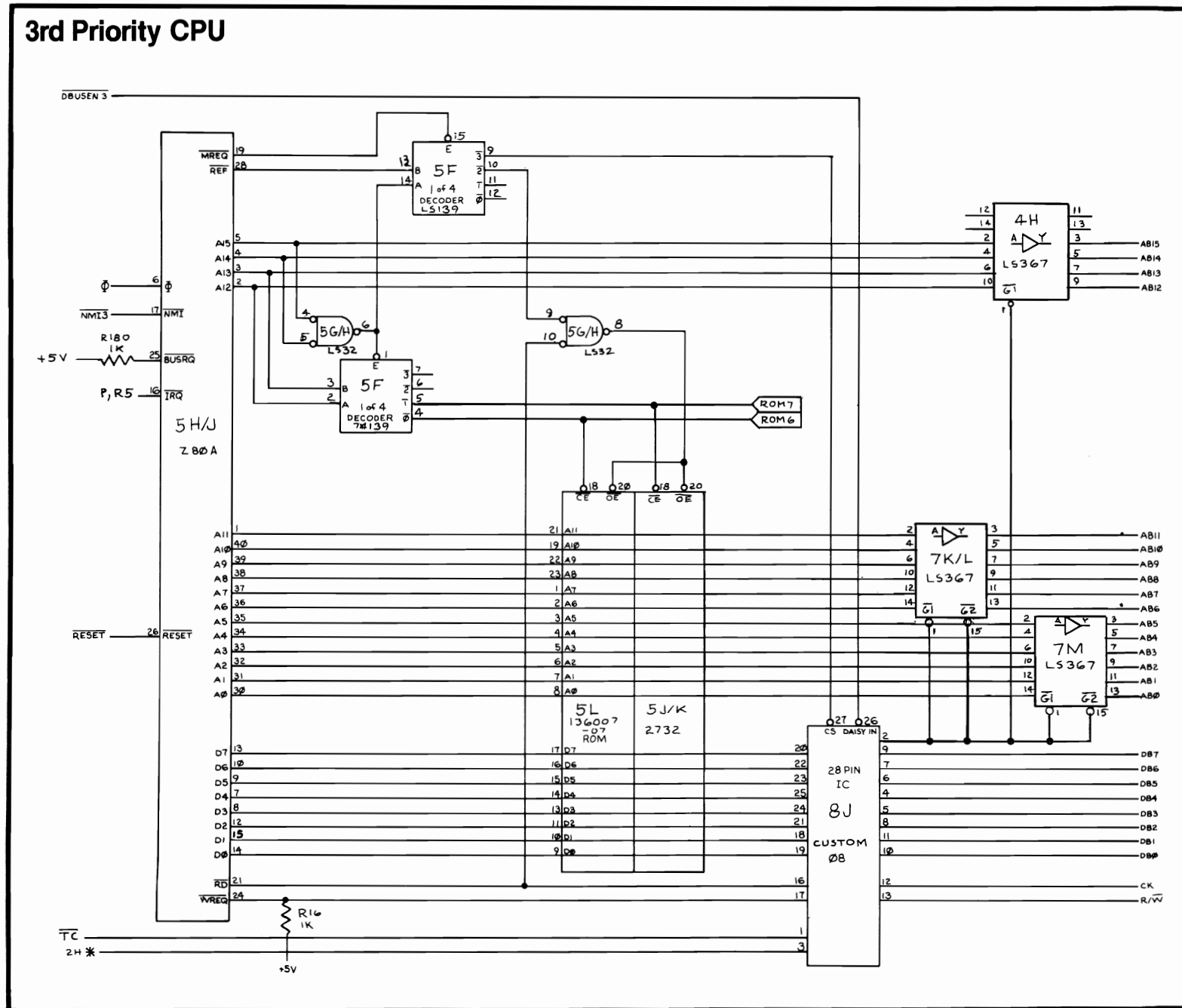

Address Decoder

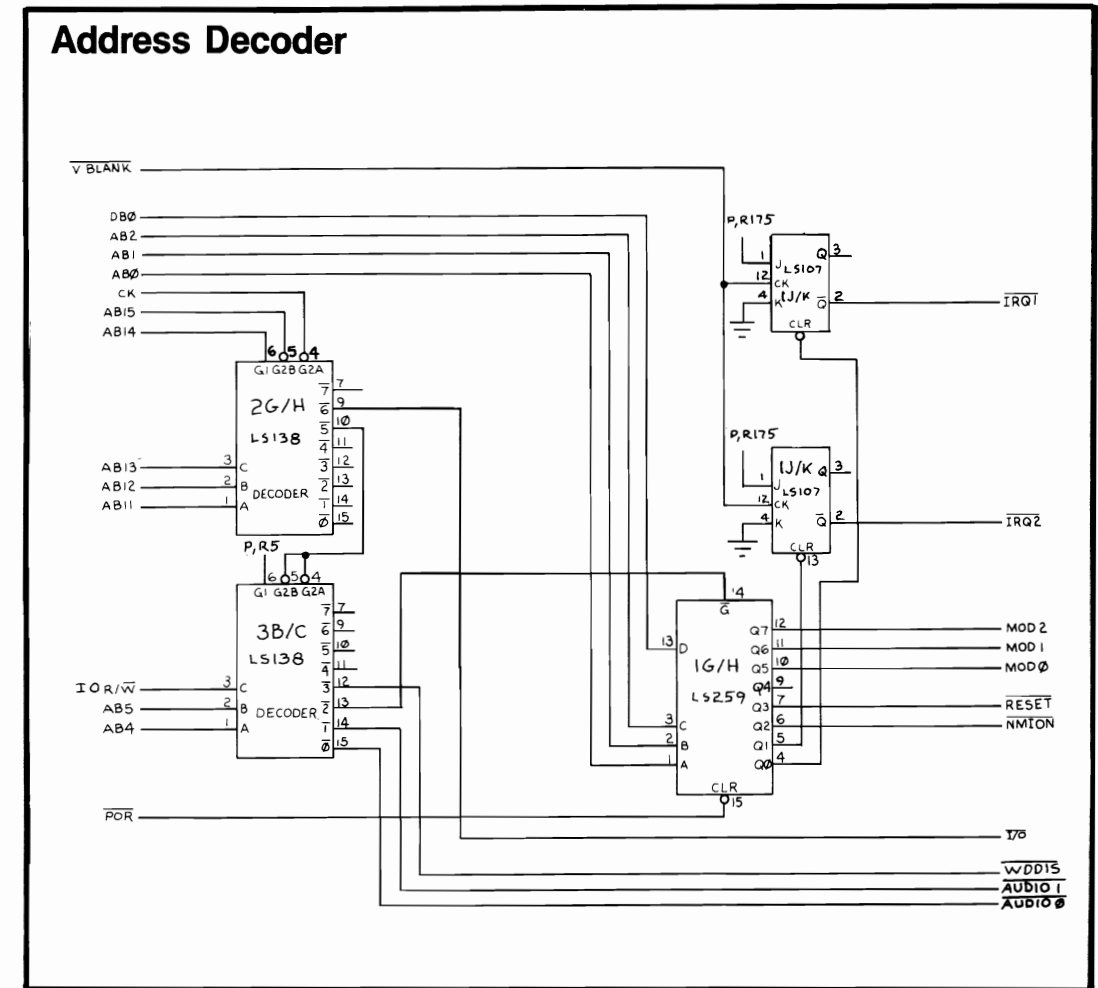

NOTICE TO ALL PERSONS RECEIVING THIS DRAWING
 CONFIDENTIAL: Reproduction forbidden without the specific written permission of Atari, Inc., Sunnyvale, CA. This drawing is only conditionally issued, and neither receipt nor possession thereof confers or transfers any right in, or license to use, the subject matter of the drawing or any design or technical information shown thereon, nor any right to reproduce this drawing or any part thereof. Except for manufacture by vendors of Atari, Inc., and for manufacture under the corporation's written license, no right is granted to reproduce this drawing or the subject matter thereof, unless by written agreement with or written permission from the corporation.

Dig Dug Game PCB Schematic Diagram

© ATARI INC., 1982
 A Warner Communications Company

SP-203 Sheet 5A
 3rd printing 5L

Switch Inputs, Coin Door and Control Panel Outputs

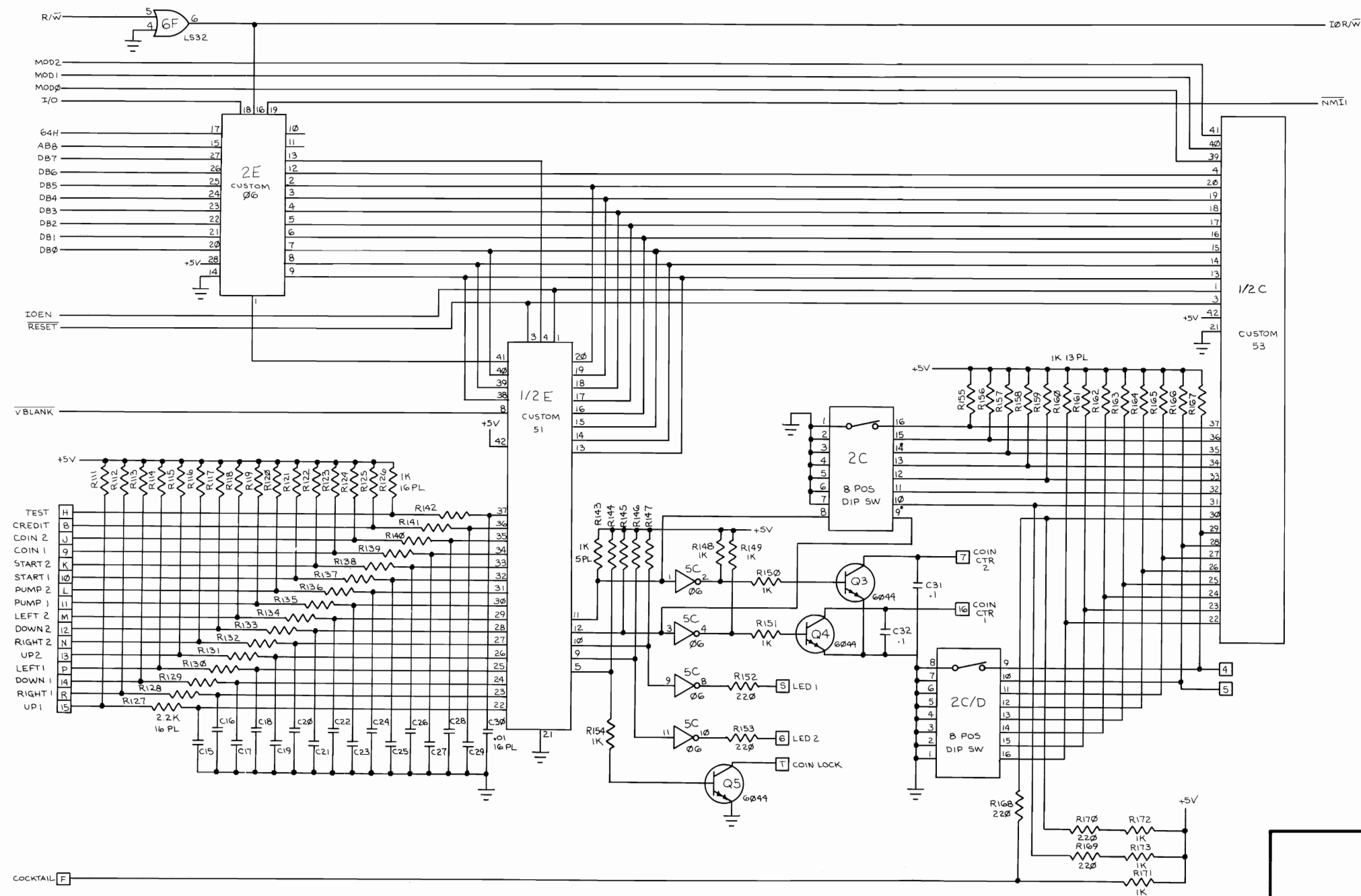

NOTICE TO ALL PERSONS RECEIVING THIS DRAWING
 CONFIDENTIAL: Reproduction forbidden without the specific written permission of Atari, Inc., Sunnyvale, CA. This drawing is only conditionally issued, and neither receipt nor possession thereof confers or transfers any right in, or license to use, the subject matter of the drawing or any design or technical information shown thereon, nor any right to reproduce this drawing or any part thereof. Except for manufacture by vendors of Atari, Inc., and for manufacture under the corporation's written license, no right is granted to reproduce this drawing or the subject matter thereof, unless by written agreement with or written permission from the corporation.

Dig Dug Game PCB Schematic Diagram

© ATARI INC., 1982
 A Warner Communications Company

SP-203 Sheet 5B
 3rd printing 5L

Audio

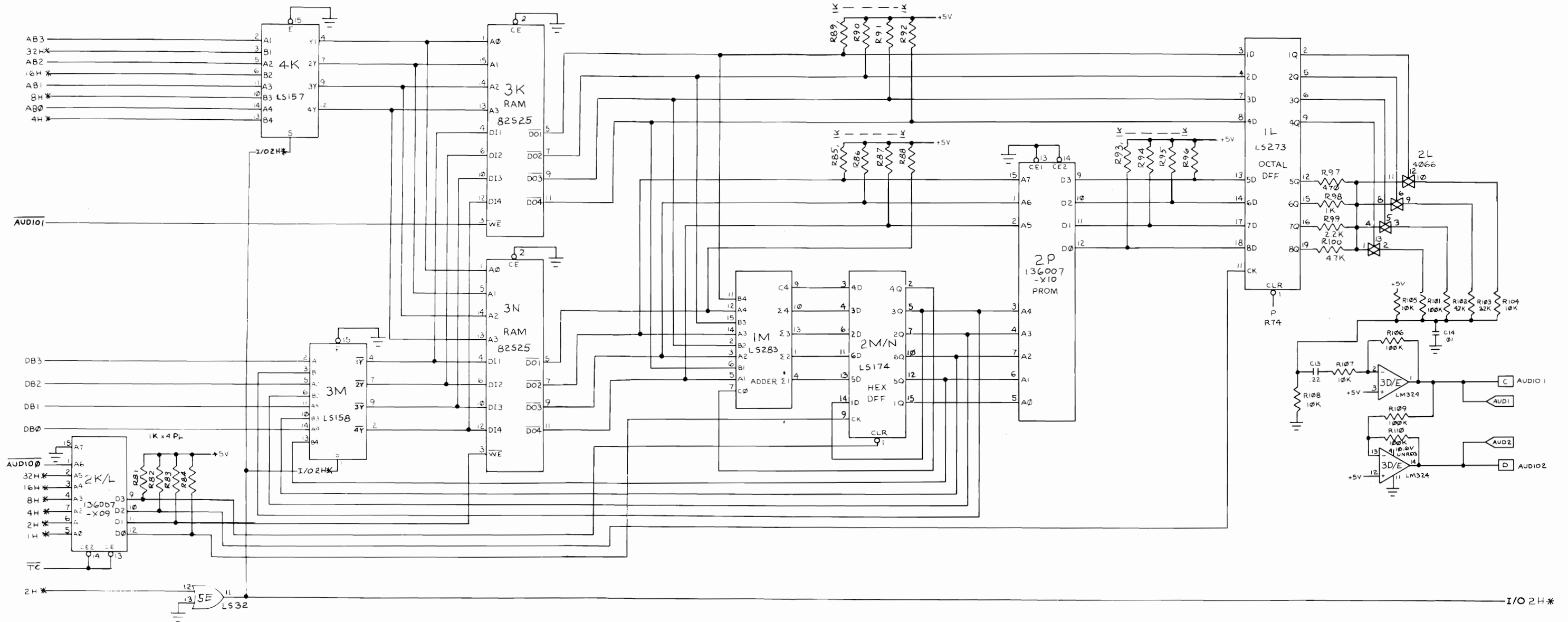

NOTICE TO ALL PERSONS RECEIVING THIS DRAWING
 CONFIDENTIAL: Reproduction forbidden without the specific written permission of Atari, Inc., Sunnyvale, CA. This drawing is only conditionally issued, and neither receipt nor possession thereof confers or transfers any right in, or license to use, the subject matter of the drawing or any design or technical information shown thereon, nor any right to reproduce this drawing or any part thereof. Except for manufacture by vendors of Atari, Inc., and for manufacture under the corporation's written license, no right is granted to reproduce this drawing or the subject matter thereof, unless by written agreement with or written permission from the corporation.

Dig Dug Game PCB Schematic Diagram

© ATARI INC., 1982
 A Warner Communications Company

SP-203 Sheet 6A
 3rd printing 5L

Sync Generator

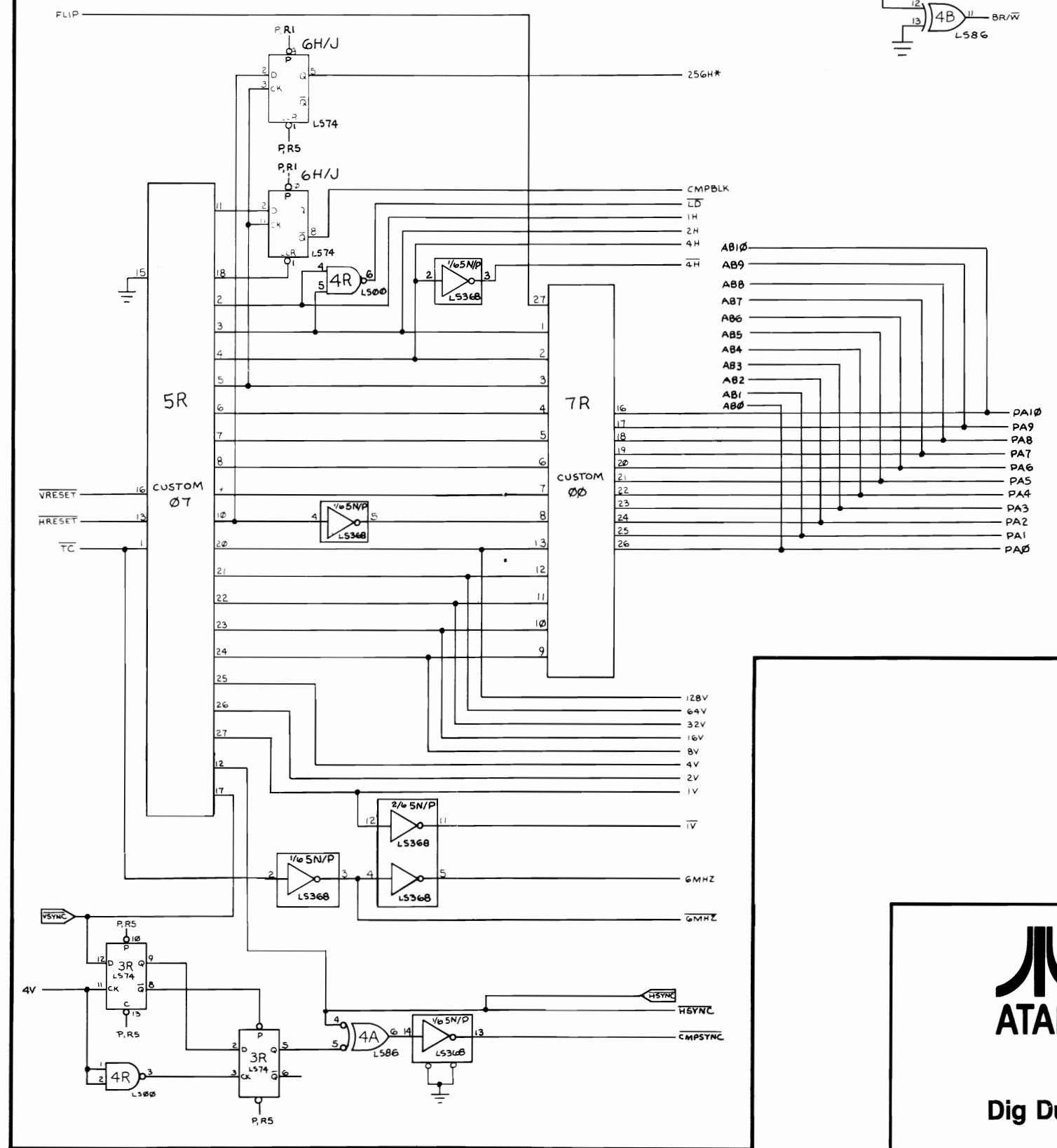



ATARI

NOTICE TO ALL PERSONS RECEIVING THIS DRAWING
 CONFIDENTIAL: Reproduction forbidden without the specific written permission of Atari, Inc., Sunnyvale, CA. This drawing is only conditionally issued, and neither receipt nor possession thereof confers or transfers any right in, or license to use, the subject matter of the drawing or any design or technical information shown thereon, nor any right to reproduce this drawing or any part thereof. Except for manufacture by vendors of Atari, Inc., and for manufacture under the corporation's written license, no right is granted to reproduce this drawing or the subject matter thereof, unless by written agreement with or written permission from the corporation.

Dig Dug Game PCB Schematic Diagram

© ATARI INC., 1982
 A Warner Communications Company

SP-203 Sheet 6B
 3rd printing 5L

Playfield Generator

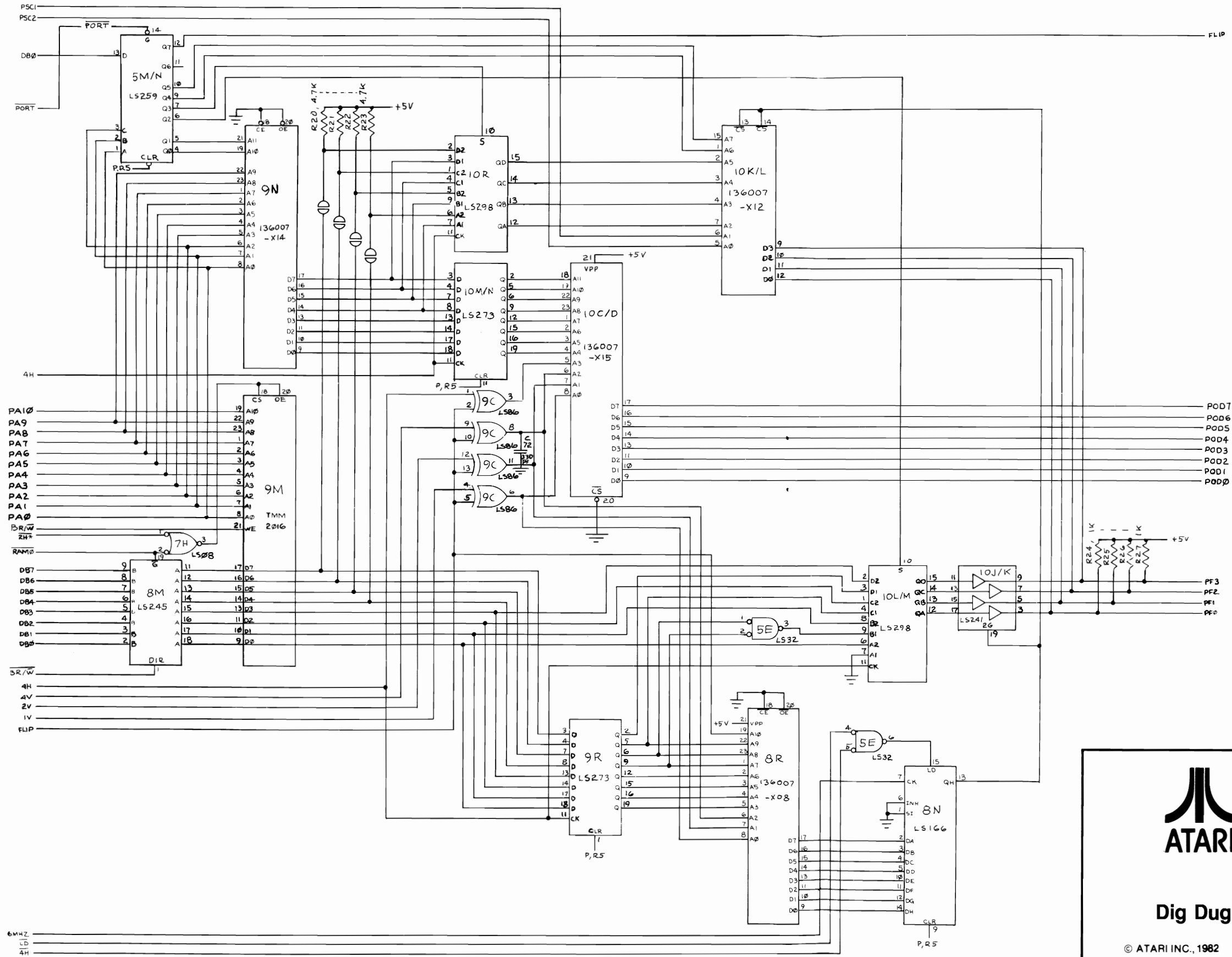



NOTICE TO ALL PERSONS RECEIVING THIS DRAWING
 CONFIDENTIAL: Reproduction forbidden without the specific written permission of Atari, Inc., Sunnyvale, CA. This drawing is only conditionally issued, and neither receipt nor possession thereof confers or transfers any right in, or license to use, the subject matter of the drawing or any design or technical information shown thereon, nor any right to reproduce this drawing or any part thereof. Except for manufacture by vendors of Atari, Inc., and for manufacture under the corporation's written license, no right is granted to reproduce this drawing or the subject matter thereof, unless by written agreement with or written permission from the corporation.

Dig Dug Game PCB Schematic Diagram

© ATARI INC., 1982
 A Warner Communications Company

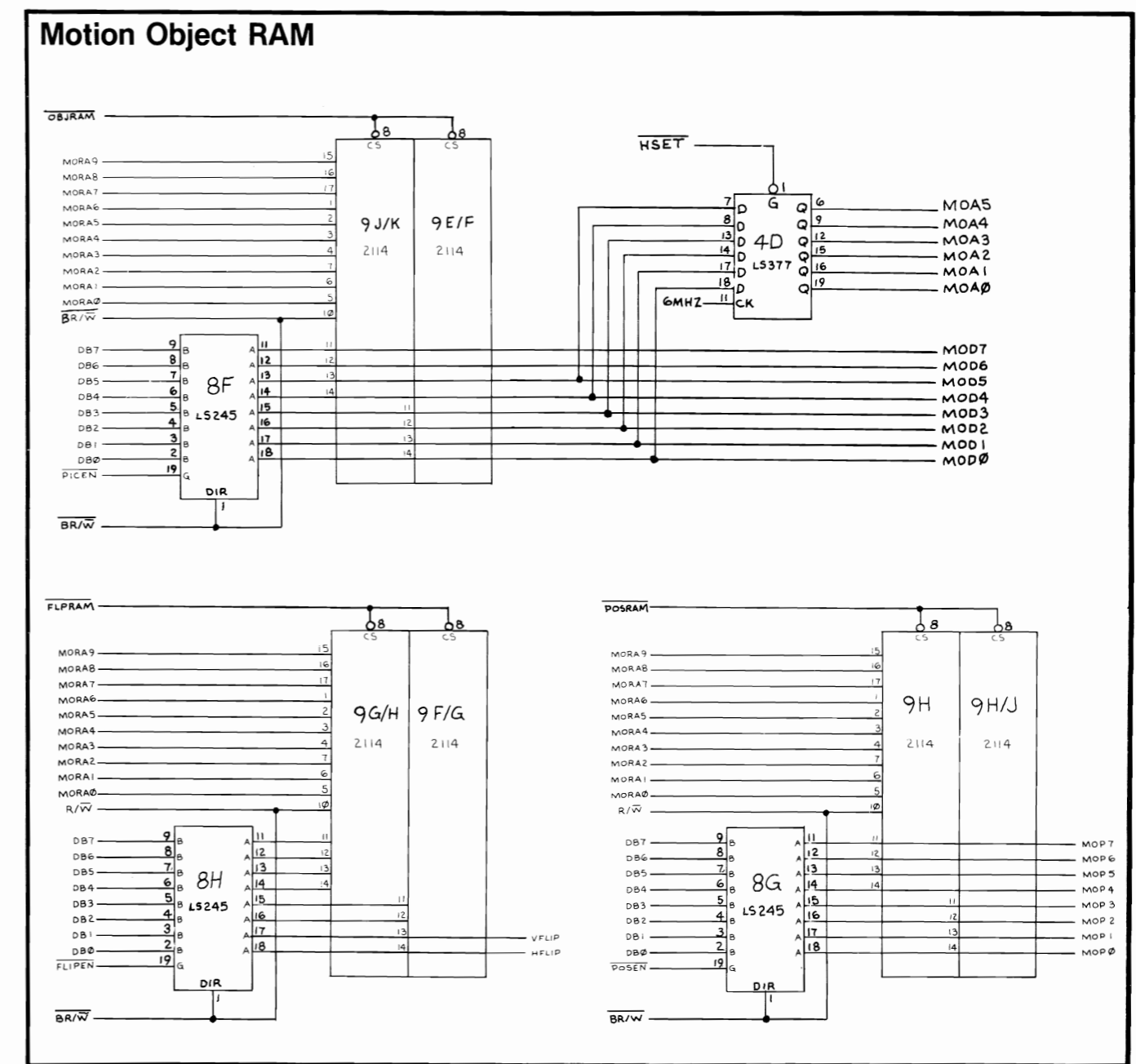
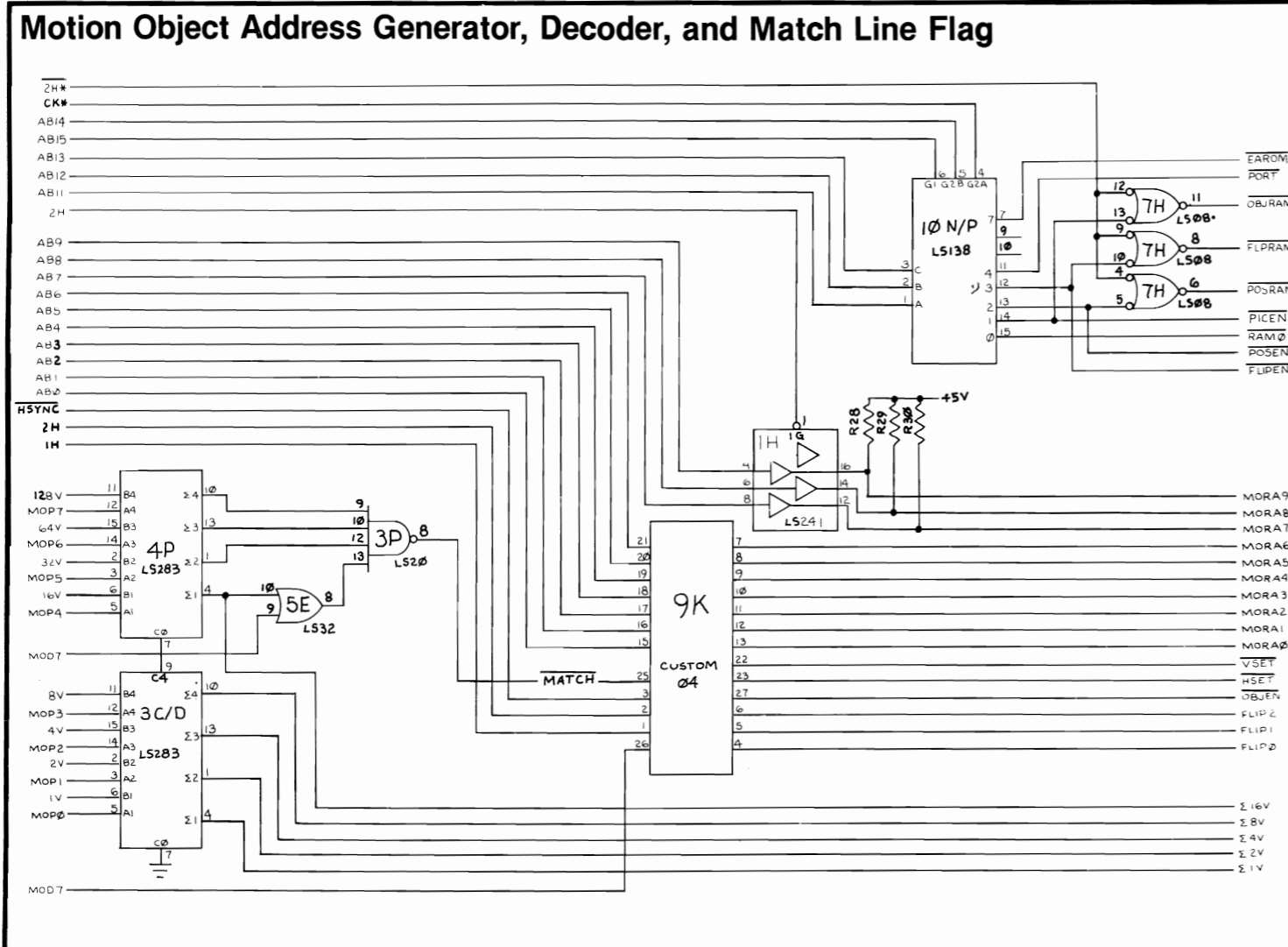
SP-203 Sheet 7A
 3rd printing 5L





NOTICE TO ALL PERSONS RECEIVING THIS DRAWING
 CONFIDENTIAL: Reproduction forbidden without the specific written permission of Atari, Inc., Sunnyvale, CA. This drawing is only conditionally issued, and neither receipt nor possession thereof confers or transfers any right in, or license to use, the subject matter of the drawing or any design or technical information shown thereon, nor any right to reproduce this drawing or any part thereof. Except for manufacture by vendors of Atari, Inc., and for manufacture under the corporation's written license, no right is granted to reproduce this drawing or the subject matter thereof, unless by written agreement with or written permission from the corporation.

Dig Dug Game PCB Schematic Diagram

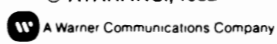
© ATARI INC., 1982
 A Warner Communications Company

SP-203 Sheet 7B
 3rd printing 5L

Motion Object Generator

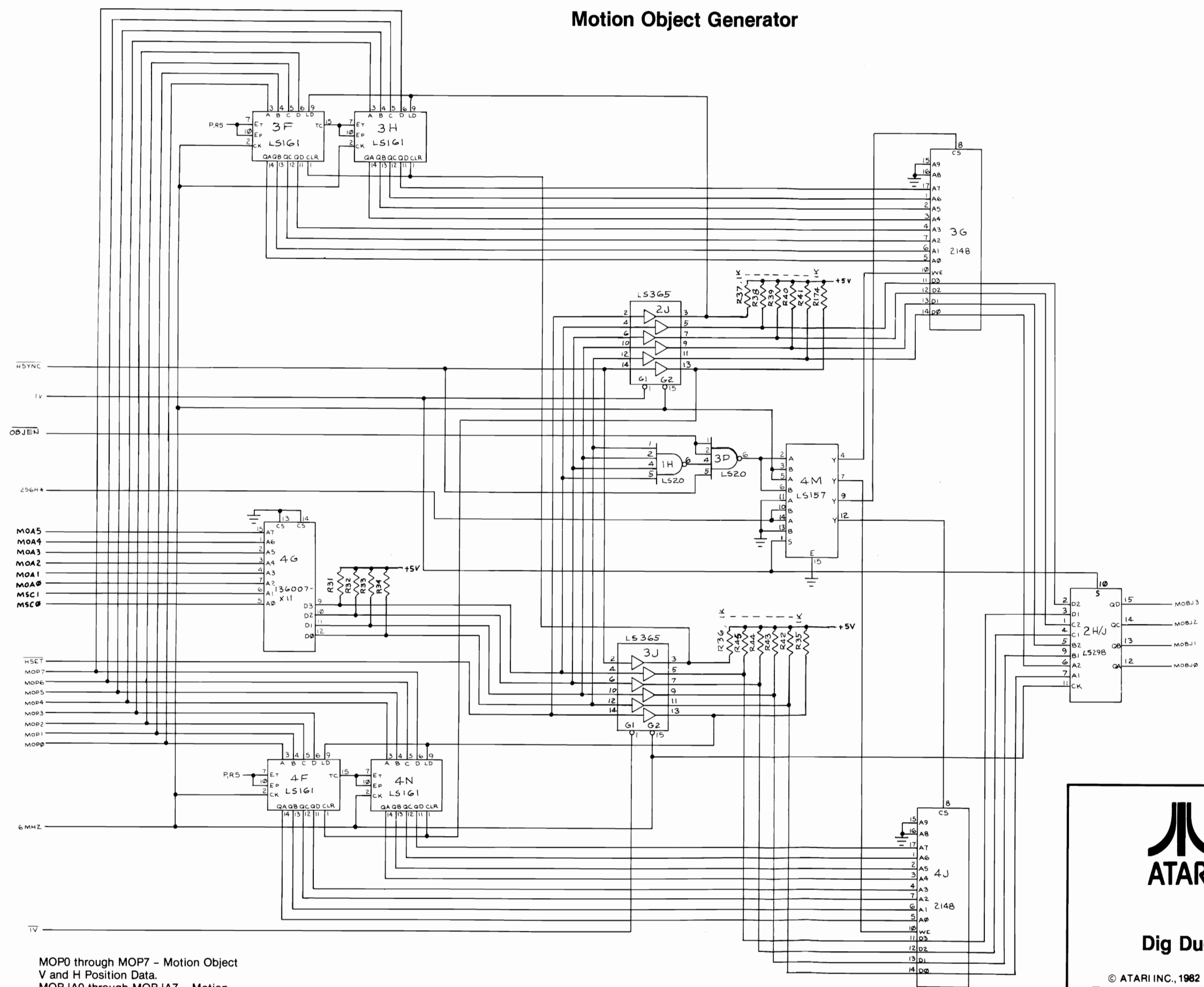

MOBJ0 through MOBJ3 -
Motion Object Output.

MOP0 through MOP7 - Motion Object
V and H Position Data.
MOBJA0 through MOBJA7 - Motion
Object Picture Address.



NOTICE TO ALL PERSONS RECEIVING THIS DRAWING
CONFIDENTIAL: Reproduction forbidden without the specific written permission of Atari, Inc., Sunnyvale, CA. This drawing is only conditionally issued, and neither receipt nor possession thereof confers or transfers any right in, or license to use, the subject matter of the drawing or any design or technical information shown thereon, nor any right to reproduce this drawing or any part thereof. Except for manufacture by vendors of Atari, Inc., and for manufacture under the corporation's written license, no right is granted to reproduce this drawing or the subject matter thereof, unless by written agreement with or written permission from the corporation.

Dig Dug Game PCB Schematic Diagram

© ATARI INC., 1982
A Warner Communications Company

SP-203 Sheet 8A
3rd printing 5L

Video Output

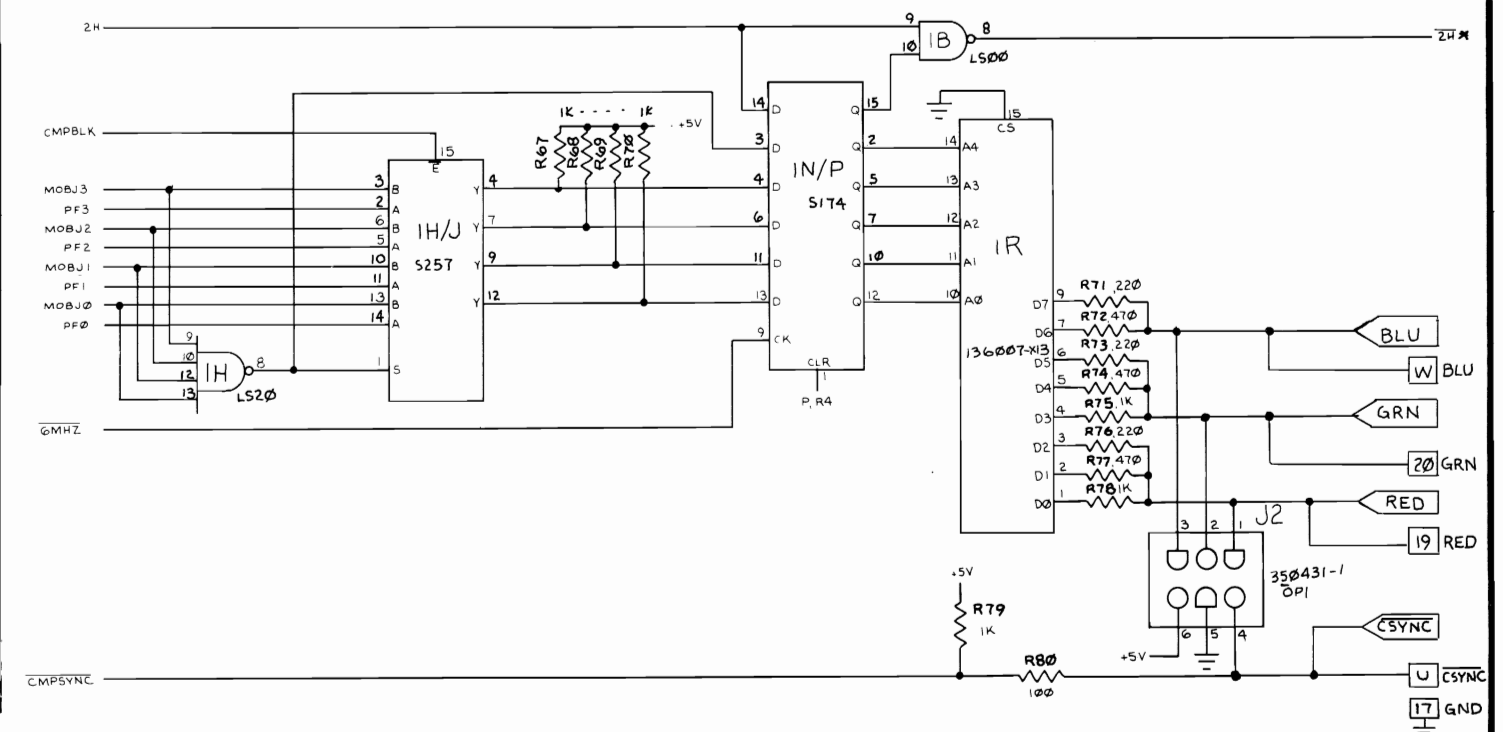

Video Color Controller

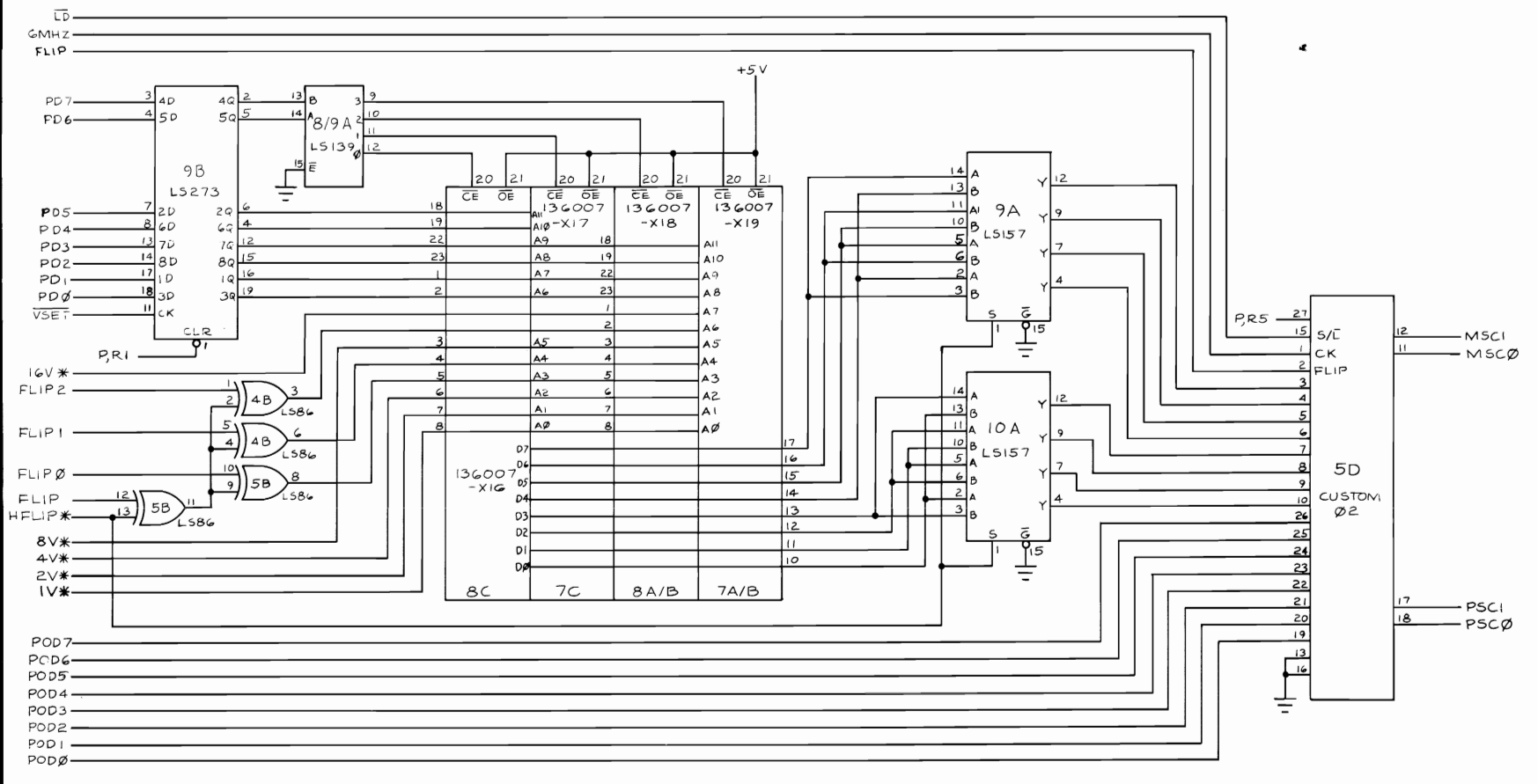

NOTICE TO ALL PERSONS RECEIVING THIS DRAWING
 CONFIDENTIAL: Reproduction forbidden without the specific written permission of Atari, Inc., Sunnyvale, CA. This drawing is only conditionally issued, and neither receipt nor possession thereof confers or transfers any right in, or license to use, the subject matter of the drawing or any design or technical information shown thereon, nor any right to reproduce this drawing or any part thereof. Except for manufacture by vendors of Atari, Inc., and for manufacture under the corporation's written license, no right is granted to reproduce this drawing or the subject matter thereof, unless by written agreement with or written permission from the corporation.

Dig Dug Game PCB Schematic Diagram

© ATARI INC., 1982
 A Warner Communications Company

SP-203 Sheet 8B
 3rd printing 5L

Color Display Schematic Diagram

Schematic Notes

Unless otherwise specified

Resistance: (Ω) (K→KΩ, M→MΩ), 1/4 (W) carbon resistor

Capacitance: 1 or higher → (pF), less than 1 → (μF)

working voltage → 50 (V)

ceramic capacitor

Inductance: (μH)

Electrolytic Cap: Capacitance Value (μF)/working voltage (V),

NP → non-polar (or bipolar) electrolytic cap.

Refer to the parts list for additional component information.

⊕ indicates test point connection

⊔ indicates chassis ground unless otherwise specified

Hz indicates cycles per second

For **safety** purposes (and continuing reliability)

⚠ replace all components marked with safety symbol with identical type.

NOTE: FR → fusible resistor

Parts identification on circuit boards:

e.g. SU1126A (R107 = R1107)

SU3030A (R113 = R3113)

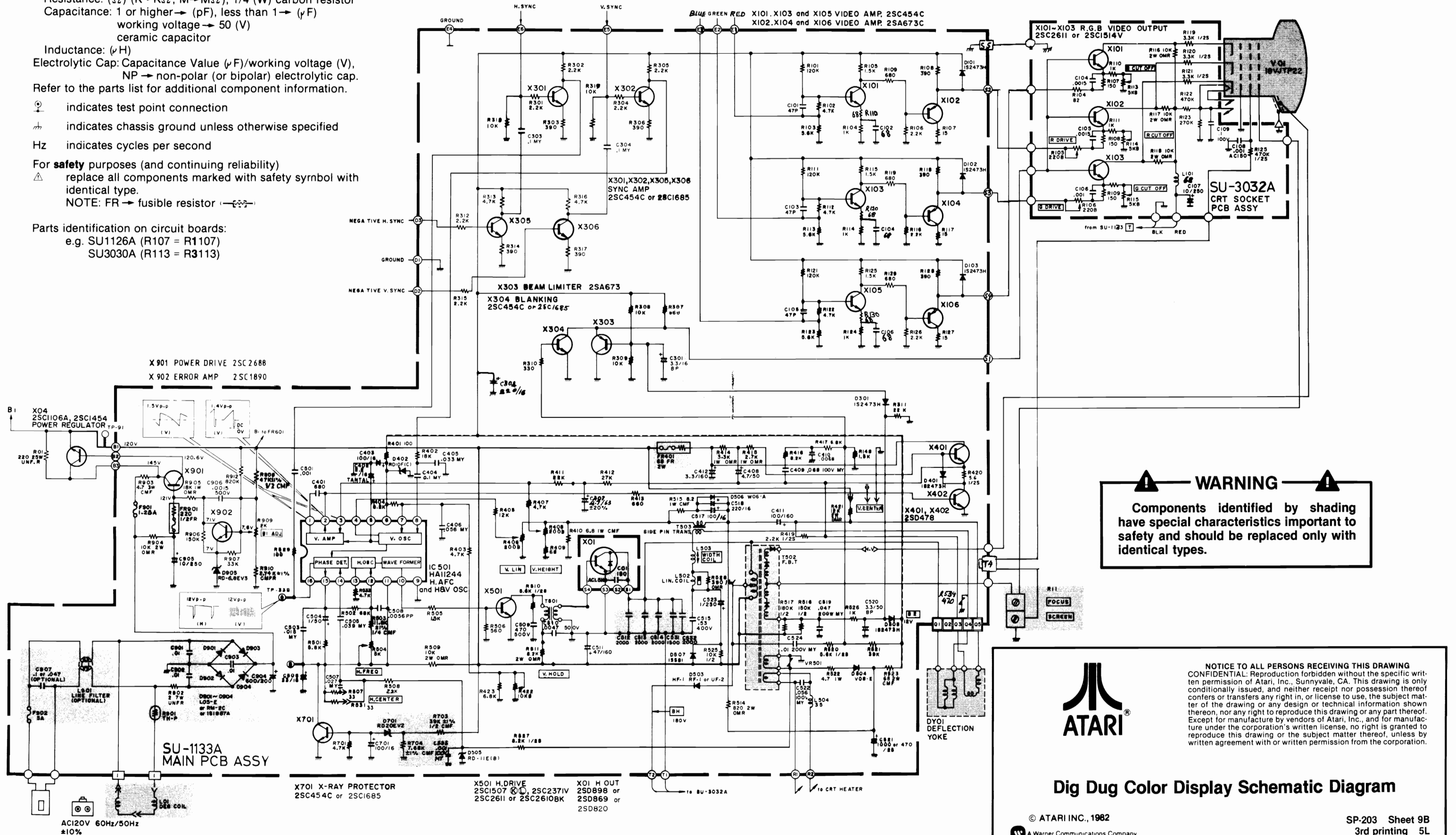

WARNING

Components identified by shading have special characteristics important to safety and should be replaced only with identical types.

ATARI

Dig Dug Color Display Schematic Diagram

© ATARI INC., 1982
A Warner Communications Company

SP-203 Sheet 9B
3rd printing 5L

NOTICE TO ALL PERSONS RECEIVING THIS DRAWING
CONFIDENTIAL: Reproduction forbidden without the specific written permission of Atari, Inc., Sunnyvale, CA. This drawing is only conditionally issued, and neither receipt nor possession thereof confers or transfers any right in, or license to use, the subject matter of the drawing or any design or technical information shown thereon, nor any right to reproduce this drawing or any part thereof. Except for manufacture by vendors of Atari, Inc., and for manufacture under the corporation's written license, no right is granted to reproduce this drawing or the subject matter thereof, unless by written agreement with or written permission from the corporation.