CONTENTS

Introduction	4-3
Selecting Line Voltage	4-3
Selecting Mainframe Line Voltage	4-3
Selecting Monitor Line Voltage	4-6
Changing Fuses	4-7
Changing the Mainframe Fuse	4-7
Changing the Probe Fuse	4-7
Changing the Clock Module Fuse	4-7
Changing the I/O Module Fuse	4-8
Cleaning	4-8
General	4-8
Fan Filter	4-9
Floppy Disk Drive	4-9
Mainframe Access, Removal, and Installation Techniques	4-9
System Connections	4-9
Mainframe Access	4-9
Operator Keypad/Display	4-12
Removing the Assembly	4-12
Separating the Subassembly	4-12
Disassembling the Keypad	4-12
Disassembling the Disk System	4-14
Removing the Hard Disk Controller	4-14
Removing the Disk Drive Assemblies	4-14
Installing the Disk Drive Assemblies	4-14
Removing the Power Supply	4-14
Removing the MFI and Video Controller PCAs	4-16
Removing the I/O Connector Interface PCA	4-16
Removing the Probe I/O Module Interface PCA	4-16
Removing the Main PCA	4-16
Programmer Keyboard Access Procedure	4-17
Screen Overlay	4-18
Recommended Use	4-18
Removing the Overlay	4-18
Installing the Overlay	4-18
Monitor Access, Removal, Installation Techniques	4-19
Removing the Monitor Cover	4-19
Accessing the Monitor Chassis	4-19
Removing the Front Bezel	4-19
Monitor Power Supply	4-21
Removing the Monitor Power Supply	4-21
Installing the Monitor Power Supply	4-22

Monitor Display PCA	4-24
Removing the Display PCA	4-24
Installing the Display PCA	4-26
CRT and Yoke	4-28
Removing the CRT and Yoke	4-28
Installing the CRT and Yoke	4-30
Monitor Adjustment	4-32
Deciding on CRT Replacement	4-37
Self Test Routines	4-38
Power-Up Self Test	4-38
Probe Self Test	4-38
Pod Self Test	4-41
I/O Module Self Test	4-42
Display Self Test	4-42
Calibration	4-45
Probe Offset Correction	4-46
Probe Compensation	4-46
Software Calibration	4-48
Probe to External (Clock Module)	4-48
Probe to Pod	4-49
I/O Module to External	4-50
I/O Module to Pod	4-50
Saving and Restoring Calibration Data	4-51
Invalid Calibration Data	4-52
Saving Calibration Data	4-52
Restoring Calibration Data	4-53
Troubleshooting	4-54
Repair	4-54
General Repair	4-54
Static Awareness	4-54
Components	4-54
Surface Mount Repair	4-54
Surface Mount Technology	4-54
Repair Techniques	4-60
Tools and Supplies	4-64
Repair Information	4-66
General	4-66
Main PCA	4-66
Display and Keypad	4-66
Probe I/O	4-67
I/O Connector	4-67
Clock Module	4-67
Single-Point Probe	4-67
RAM Modules	4-68
Power Supply	4-68
Floppy Disk Drive	4-69
Hard Disk and Controller	4-69
Multi-Function Interface	4-70
Video Controller	4-70
Monochrome Monitor	4-71
I/O Module	4-71
Clip and Flying Lead Modules	4-71

WARNING

SERVICING DESCRIBED IN THIS SECTION IS TO BE PERFORMED BY QUALIFIED SERVICE PERSONNEL ONLY. TO AVOID ELECTRICAL SHOCK, DO NOT PERFORM ANY SERVICING UNLESS YOU ARE QUALIFIED TO DO SO.

INTRODUCTION

This section describes maintenance procedures for the 9100A/9105A. Some of these procedures do not require access to the instrument and can be performed by the operator. Troubleshooting procedures, which are covered in detail in the 9100A/9105A Service Kit, may require reference to the disassembly and reassembly instructions found in this section.

Refer to Table 4-1 for a list of tools and test equipment required during 9100A/9105A maintenance.

SELECTING LINE VOLTAGE

Selecting Mainframe Line Voltage

The mainframe line voltage selection switch is located on the 9100A/9105A rear panel. The switch setting (110V or 220V) must correspond to the local line voltage as follows:

Setting	Voltage/Frequency Range	Required Fuse (F1)
110V	90 to 132V ac, 47 to 440 Hz	2A SLOW BLOW
220V	180 to 264V ac, 47 to 63 Hz	1A SLOW BLOW

A correct setting can be verified visually at any time. Otherwise, to change the setting, use the following procedure:

1. Ensure that the 9100A/9105A is turned off and its line power cord is disconnected.
2. Rotate the rear panel switch to the desired setting (110V or 220V).
3. If necessary, replace the power fuse as described later in this section. See Table 4-2 for the fuse part number.
4. Connect the power cord to the correct line voltage, and turn the 9100A/9105A on.

Table 4-1. Required Tools and Test Equipment

EQUIPMENT REQUIRED FOR GENERAL SERVICING		
EQUIPMENT	RECOMMENDED MODEL	FUNCTION/COMMENTS
Digital Multimeter	Fluke Model 77	
Oscilloscope	Philips Model PM3065 (or equivalent)	
Adjustment Tool	P/N 800540	
Flat Blade Screwdriver		1/8-inch (3 mm) blade
Flat Blade Screwdriver		1/4-inch (6 mm) blade
Phillips Screwdriver		#2, blade 4 inches (10 cm) or longer
Hex Driver		3/16-inch (5 mm)
Hex Driver		5/16-inch (8 mm)
Wrench		3/16-inch (5 mm) or adjustable
REQUIRED EQUIPMENT FOR COMPONENT LEVEL REPAIR		
EQUIPMENT	RECOMMENDED MODEL	FUNCTION/COMMENTS
9100A Service Kit	P/N 818948	
Digital Test Station, with I/O Module	Fluke Model 9105A (or 9100A) with 9100A-003 option	Runs programs supplied with Service Kit
68000 Interface Pod	Fluke Model 9000A-68000	Used with Service Kit
Surface Mount Repair tools		See Table 4-6

Table 4-1. Required Tools and Test Equipment (cont.)

REQUIRED EQUIPMENT FOR MONOCHROME MONITOR MAINTENANCE		
EQUIPMENT	RECOMMENDED MODEL	FUNCTION/COMMENTS
Hex Adjustment Tool	P/N 572321	Horizontal Size/Linearity
Alignment Template	P/N 777144	Use with Monitor Pattern Program
Long-Nose Pliers		
Flat-Blade Screwdriver		1/4-inch (6 mm) blade, plastic handle with blade at least 5 inches (12.5 cm) long.
Phillips Screwdriver		#2, plastic handle with blade at least 3 inches (7.5 cm) long.
Phillips Screwdriver		#2, non-magnetic tip blade, plastic handle, with blade at least 12 inches (30 cm) long, for crt replacement.
Torque Hex Driver		3/16-inch (5 mm).
Soft Pad (foam or quilted)		Approximately 8 x 10 inches (20 x 25 cm).
1 megohm, 1W Resistor	P/N 109793	To discharge crt anode.
Clip Leads (2)		For connecting resistor to chassis and screwdriver shaft.
Safety Gloves		Mid-forearm length, soft leather.
Full Face Shield (preferred) or Safety Goggles		
Lab Smock with Zipper		Plastic zipper. Metal parts should not come in contact with crt.

Selecting Monitor Line Voltage

The line voltage selection switch for the Fluke Monochrome Monitor is located on the monitor rear panel. The mainframe voltage setting (110V or 220V) must be repeated with the Monitor. No fuse changes are required with monitor line voltage changes.

Setting	Voltage/Frequency Range
110V	90 to 132V ac, 47 to 440 Hz
220V	180 to 264V ac, 47 to 440 Hz

To change the setting, use the following procedure:

1. Set the rear panel power switch to off ("0").
2. Rotate the rear panel switch to the desired setting (110V or 220V).
3. Connect the power cord to the correct line voltage, and set the power switch to on ("1").

CHANGING FUSES

Changing the Mainframe Fuse

The mainframe fuse (labeled F1) is accessible from the rear panel. Prior to changing the fuse, set power to off and remove the line power cord. Then, press in and turn the fuse holder cap counterclockwise. Fuse sizes are:

110V	2A SLOW BLOW
220V	1A SLOW BLOW

See Table 4-2 for fuse part numbers.

Changing the Probe Fuse

An operator display message ("probe fuse blown") indicates that the probe fuse has opened. This problem can occur when the probe common lead is incorrectly connected to the UUT.

Prior to replacing the fuse, determine the incorrect common lead connection. Then disconnect probe leads and replace the fuse as follows:

1. Locate the fuse holder, labeled PROBE FUSE, on the mainframe right side.
2. Press the fuse holder cap in, then rotate it counterclockwise.
3. Pull the cap and fuse straight out. Separate the fuse cap and fuse.
4. Use a 0.25A, 250V fast-blow fuse. See Table 4-2 for the fuse part number.

Changing the Clock Module Fuse

An operator display message ("clock module fuse blown") indicates that the Clock Module fuse has opened. This problem can occur when the Clock Module COMMON lead is incorrectly connected to the UUT.

Prior to replacing the fuse, determine the incorrect COMMON lead connection. Then disconnect all Clock Module leads and replace the fuse as follows:

1. Locate the fuse holder on the Clock Module.
2. Press the fuse holder cap in, then rotate it counterclockwise.
3. Pull the cap and fuse straight out. Separate the cap and fuse.
4. Use a 0.25A, 250V fast-blow fuse. See Table 4-2 for the fuse part number.

Changing the I/O Module Fuse

An operator display message ("I/O module fuse blown") indicates that the I/O Module fuse has opened. This problem can occur when the I/O Module COMMON lead is incorrectly connected to the UUT.

Prior to replacing the fuse, determine the incorrect COMMON lead connection. Then disconnect all I/O Module leads and replace the fuse as follows:

1. Locate the fuse holder on the back of the I/O Module, near the cable.
2. Press the fuse holder cap in, then rotate it counterclockwise.
3. Pull the cap and fuse straight out. Separate the cap and fuse.
4. Use a 1A, 250V slow blow fuse. See Table 4-2 for the fuse part number.

Each 9100A or 9105A uses one of two different types of fuses. Instruments configured at the factory for 110V line voltage use 1/4 x 1-1/4 inch fuses with grey fuse holder caps. Instruments configured at the factory for 220V use 5 mm x 20 mm fuses with black fuse holder caps. First, check the color of the fuse cap (grey caps hold U.S. fuses; black caps hold metric fuses). Then select the fuse part number as shown in Table 4-2.

Table 4-2. Fuse Part Numbers

FUSE	US P/N	METRIC P/N
2A SLOW BLOW:	109181	na
1A SLOW BLOW:	109272	808055
0.25A FAST BLOW:	109314	543504

The fuse holder cap is part number 460238 for U.S (grey) usage and 461020 for metric (black) usage.

CLEANING

General

CAUTION

Do not use aromatic hydrocarbons (such as gasoline or other fuels) or chlorinated solvents for cleaning. They may damage plastic materials used in the instrument.

Avoid using excessive amounts of liquid, particularly around the keypad, keyboard, or disk drives.

Both the operator's display and the monitor screen should be cleaned with a soft cloth that has been lightly dampened with a cleaner. Commercially-available lens or crt cleaners or nonabrasive household cleaners are appropriate for this purpose.

Clean the instrument exterior and accessory cables with either a mild solution of detergent and water or a nonabrasive household cleaner.

The operator's keypad and keyboard should be cleaned gently with a cloth or towel that has been lightly dampened with either a nonabrasive household cleaner or a mild solution of detergent and water.

Fan Filter

The fan filter should be cleaned at least once every 90 days, or more often if necessary, to ensure the free flow of cooling air. The filter is positioned behind the louvered filter cover found on the mainframe right side.

To remove the filter, first pull on the cover at both sides of the upper disk drive. Once the latching pins have snapped out of the chassis, lift up on the cover until its bottom is free. Remove and clean the foam filter. Use warm water and detergent.

Floppy Disk Drive

Each floppy disk drive should be cleaned at least once a year. Cleaning involves running a commercially-available cleaning disk in the drive for five seconds.

MAINFRAME ACCESS, REMOVAL, AND INSTALLATION TECHNIQUES

System Connections

System connections are fully explained in the Getting Started guide. Here, in the Service Manual, Figures 4-1 and 4-2 also illustrate system component interconnections. If additional information about reconnecting the system is needed, refer to the Getting Started Guide.

Mainframe Access

WARNING

TO REDUCE THE RISK OF ELECTRIC SHOCK ALWAYS TURN OFF THE 9100A/9105A AND DISCONNECT THE POWER CORD FROM THE PANEL ON THE REAR OF THE CHASSIS BEFORE ACCESSING THE MAINFRAME.

1. With the instrument positioned bottom side up, remove the five screws securing the top. There are two screws on each of the side lips and one screw located at the bottom front.
2. Holding case top and bottom together, rotate the entire instrument to the top up position.
3. Working from the front of the instrument, remove the top cover by gently lifting at midpoint on both sides.

NOTE

Once the cover is free of the mainframe, notice the various cables attached between it and the mainframe. Protect these cables by proceeding cautiously with the following steps.

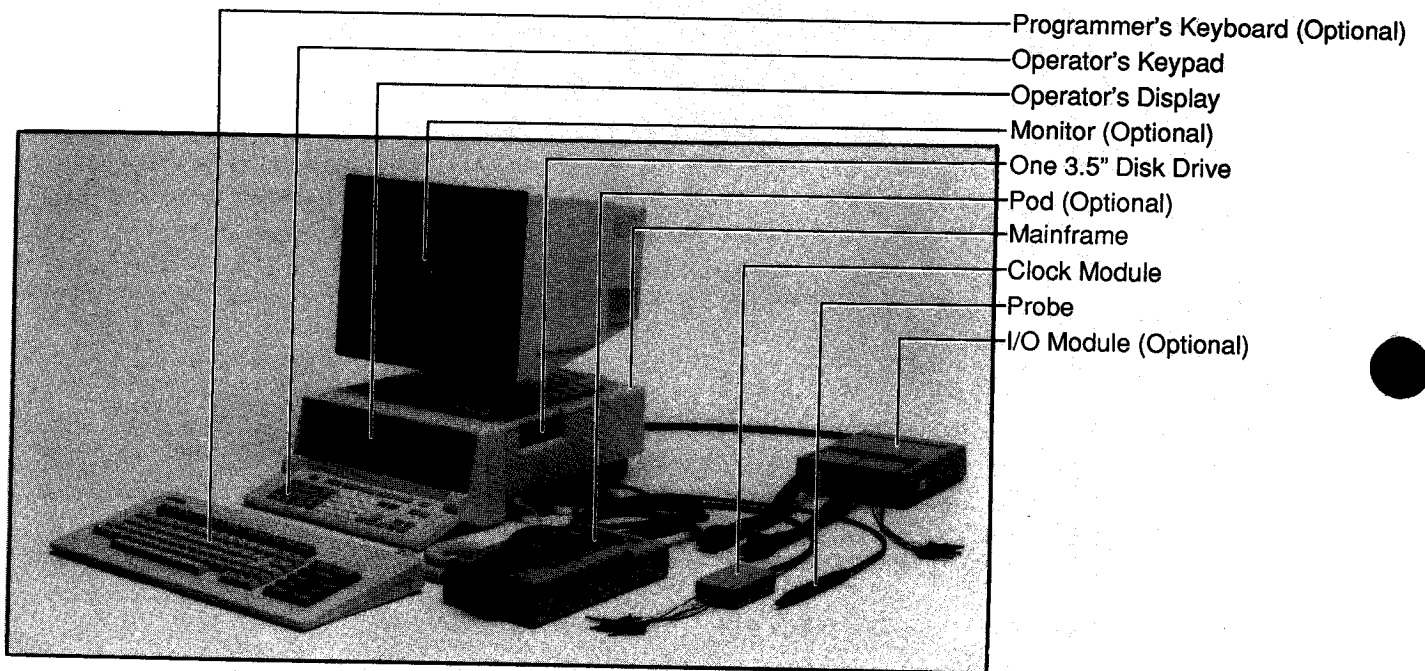

Figure 4-1. 9100A System

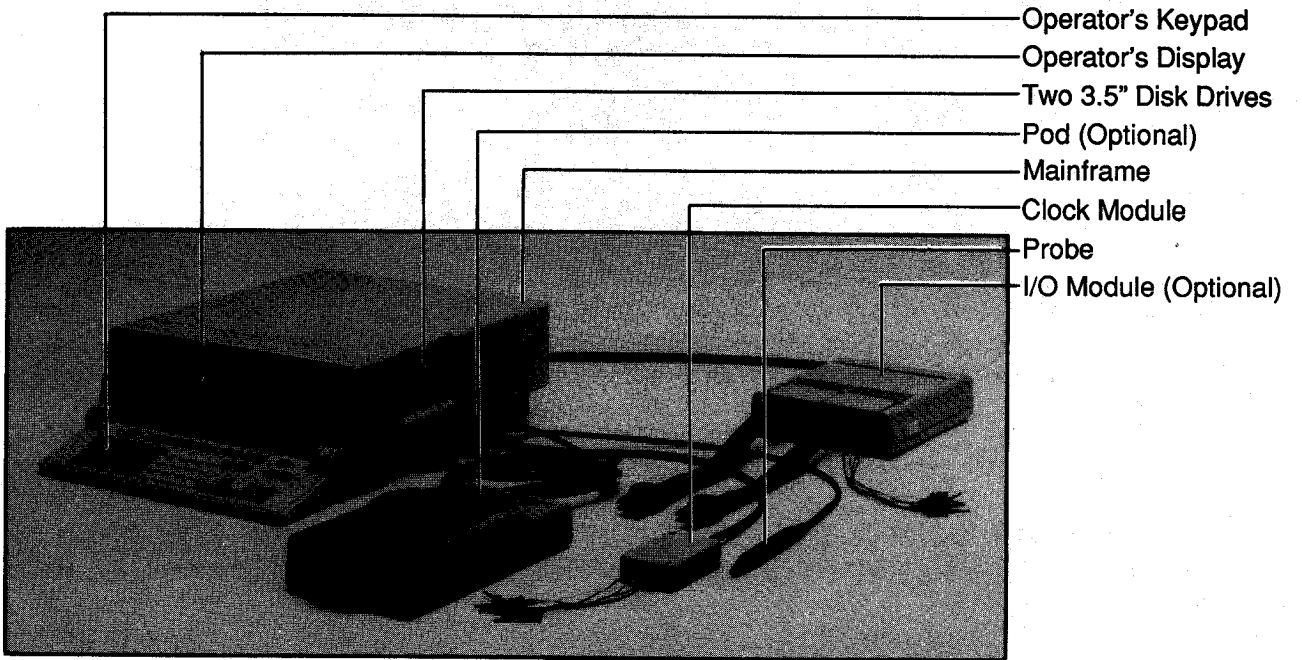

Figure 4-2. 9105A System

4/Maintenance

4. Rotate the cover 90 degrees clockwise.
5. Tilt the top cover 90 degrees to the left, placing it on a flat surface next to the mainframe. In this position, the floppy disk drive is on edge, facing forward.

CAUTION

The floppy disk drive must be positioned properly to function reliably. Do not position the removed cover so that the floppy disk drive is on top, facing up. Also, the hard disk drive (9100A only) may fail if operated in an incorrect position.

Any instrument assembly or subassembly can now be removed. Note that removal of some assemblies requires prior removal of other assemblies.

Operator Keypad/Display

REMOVING THE ASSEMBLY

The Keypad/Display is attached to the mainframe electrically with one ribbon cable and is physically attached with two screws. First, disconnect the cable at either end (J11 on the Main PCA, or J1 on the Display Interface PCA) by grasping the connector and pulling with a gentle end-to-end rocking action. Then remove the two screws (one at each pivot point), and pull the Keypad/Display free of the mainframe.

SEPARATING THE SUBASSEMBLY

The Keypad and Display can be separated by first disconnecting the ribbon cable connector at J2 (Display Interface PCA). Grasp the connector at both ends and pull with a gentle end-to-end rocking action. Then remove the two securing screws, one at each corner of the pca case. Finally, while guiding the ribbon cable and connector through the respective pca opening, pull the Keypad and Display subassemblies apart.

NOTE

On the Keypad, the two round rotator caps are no longer secured in place when the subassemblies are detached. These caps should be retained separately to avoid inadvertent loss.

When reconnecting the Keypad and Display subassemblies, route the ribbon cable/connector back through the pca opening, but avoid actual connection to the pca until the two securing screws are tightened. This sequence avoids undue stress on the cable and connector.

DISASSEMBLING THE KEYPAD

Although Keypad disassembly is seldom necessary, it can be accomplished quite easily. Before beginning disassembly, awareness of the two precautions is important.

- o Once the keypad halves are separated, the keys are no longer secured in place. Avoid key loss by separating the keypad and case only when the keypad is upside down (keys facing down).
- o Each rotator cap conceals a spring and plastic securing flange. Particularly note the flange orientation; a small "R" faces right, and a small "L" faces left. Each flange must be reinstalled in the same manner. Also, the springs are not secured in place once the keypad halves are separated and must be separately retained. When separating the keypad halves, note the location of the alignment holes used by the springs.

Use the following steps to separate the two keypad case halves:

1. Remove the screw found along the rear of the keypad.
2. Turn the keypad so that the keys face down, then pull off the securing flange revealed under each rotator cap. Note the orientation of the torsion springs (one at each end).
3. Now pry the two case halves apart, and remove the torsion springs. Leave the key half facing down until otherwise called for during reassembly.

Use the following procedure to reconnect the keypad case halves.

1. With the key half still facing down, install the torsion springs in their respective alignment holes.
2. Now, while holding each spring in place, lower the bottom half onto the key half.
3. Once the springs are properly aligned, install the two securing flanges in the same orientation as noted earlier.
4. Carefully rotate the two halves so that the keys face up. Then press and secure each of the three securing tabs along the front.
5. Install the securing screw.

Disassembling the Disk System

REMOVING THE HARD DISK CONTROLLER

On the front of the Hard Disk Controller card, apply pressure to the card edge, then carefully rock the 50-pin ribbon cable connector loose from J1.

On the rear of the card, remove the 20-pin ribbon cable connector from J2. Then disconnect P1 and J4, both found at the rear card edge.

Now physically disconnect the PCA by removing the screws and gently disengaging its standoff/retainers.

4/Maintenance

REMOVING THE DISK DRIVE ASSEMBLY

Refer to Figure 4-3. In sequence, remove the two card-edge connectors on the hard disk (9100A only), the 34-pin ribbon cable connector at J14 (Main PCA), and the seven screws securing the disk drive assembly. Grasp the assembly securely before removing the final screw.

The disk drives can now be removed from the disk drive assembly as described below.

- o Floppy Disk Drive: Remove the two screws from each side. Lift or slide the drive out. Then remove the power connector.
- o Hard Disk Drive: Remove the two screws from each side. Gently slide the drive out. Then disconnect the power connector.

CAUTION

The Hard Disk Drive is extremely fragile. Do not jar this assembly at any time during installation or removal.

INSTALLING THE DISK DRIVE ASSEMBLY

Generally, reassembling and installing the Disk Drive Assembly involves reversing the steps used above during removal. Make sure the 34-conductor ribbon cable and the 4-conductor discrete cable are not pinched between the disk drive assembly and the top cover.

Removing the Power Supply

The Power Supply Assembly uses electrical connections to the Main PCA, the rear panel fuse and power switch, and the disk drive assemblies (as applicable). Disconnect the related cables at the Main PCA and at the in-line connector leading to the rear panel fuse/power switch.

To remove the connections to the disk drives, remove the Disk Drive Assembly, and unplug the power connectors to the floppy disk drive(s), hard disk (9100A only), and hard disk controller (9100A). Disk drive disconnection can also be accomplished by removing the power supply wiring harness from the terminal blocks on the Power Supply Assembly.

Remove the five securing screws, and lift the Power Supply PCA free. Note that four shoulder screws (with nylon washers) are used in the corners. Make sure these items are used during reassembly.

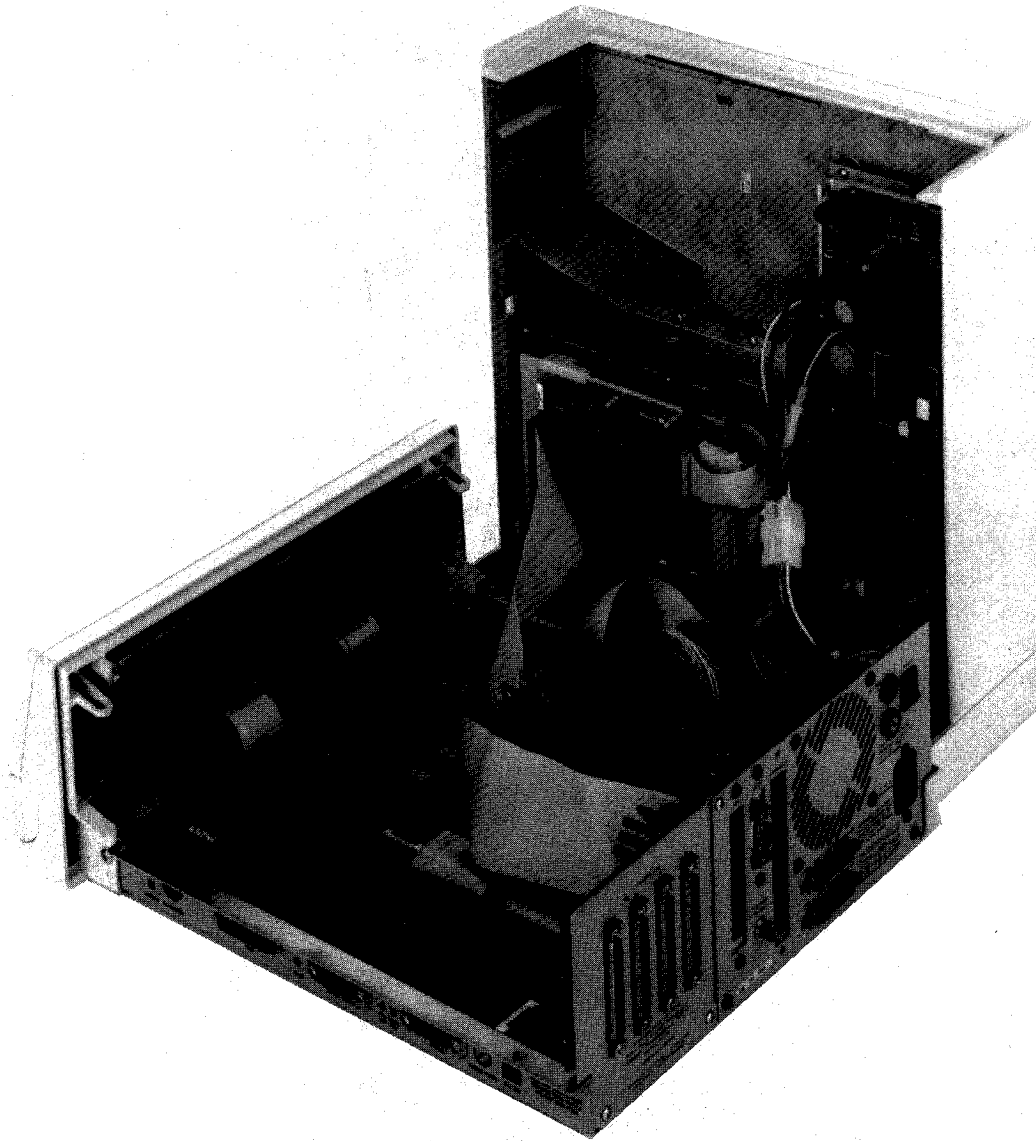

Note: Refer to system interconnect diagrams in Section 7 for electrical connection details.

Figure 4-3. Disassembly Details

4/Maintenance

If this Power Supply will not be reused in the same instrument, remove the back mounting plate. This plate adapts the Power Supply mounting requirements to those of the 9100A/9105A top cover.

Removing the MFI and Video Controller PCA

Remove the Multi-Function Interface (MFI) PCA, Video Controller PCA, or the Expansion PCA using the following procedure:

1. From the rear panel, remove the screws securing the pca.
2. To dislodge the pca from its connector, alternately lift first at the top-rear, then at the top-front.

Removing the I/O Connector Interface PCA

Remove the three screws securing the I/O Connector Interface mounting plate to the rear panel. Then pull the mounting plate and pca straight up. The pca can be detached from its mounting plate by removing the two screws securing each of the four I/O Module connectors.

Removing the Probe I/O Module Interface PCA

1. Remove the I/O Connector Interface PCA (see above).
2. Detach the ribbon cable connectors at J6 and J7. Grasp each connector at both ends and pull with a gentle end-to-end rocking action.
3. Detach the pca connector for the rear panel TRIGGER OUTPUT.
4. On the right side of the mainframe, remove two screws each for the CLOCK MODULE connector and the PROBE connector.
5. Now remove the four screws securing the pca in place.
6. Gently lift on the inside edge until the pca is detached from the remaining clip connection to the mainframe.

Removing the Main PCA

Use the following procedure for removing the Main PCA:

1. As appropriate, remove the MFI and Video Controller PCAs first.
2. Detach all connectors (8 to 10 places).
3. Remove the two connector locking posts from the pod connector on the right side of the mainframe.
4. Remove the five corner-retaining screws.
5. Gently work the Main PCA free of its mainframe retaining clips.

PROGRAMMER KEYBOARD ACCESS PROCEDURE

1. Place the keyboard on a soft pad to avoid scratching the keycaps.
2. Remove the six screws in the keyboard base plate using a Phillips screwdriver. Lift off the base plate.
3. Pull the keyboard cable connector (J3) off of the Encoder Printed Circuit Assembly (PCA).
4. Remove the ground connection, using a flat-blade screwdriver.
5. Gently pull out the three ribbon connectors from J1 and J2.
6. Remove the Encoder PCA attachment (four screws) from the keyswitch assembly using a flat-blade screwdriver.
7. Remove the keyswitch assembly from the keyboard case (four screws) using a flat-blade screwdriver.
8. To replace the keyboard components, reverse the above procedure. When replacing the three ribbon connectors, do not insert the clear acetate into the connectors.

Replace the keycaps by using the following procedure:

1. Use a flat-blade screwdriver to lift up the corner of the keycap, and lift the keycap off with your fingers.

Removing the keycap exposes a spring, a plunger, and a keyswitch base.
2. Keycaps slide on more easily if they are not pressed straight down.

To replace a keycap, position it over the plunger and press the bottom edge of the keycap down first, then press down the top edge.

NOTE

Some of the keycaps come completely off, leaving the plunger and spring on the keyswitch membrane. Other keycaps come off with the plunger still attached and the spring loose. To replace these keycaps, the plunger, spring and keycap must be properly aligned before they can be pressed down.

3. Replace the space bar using the following procedure:
 - a. Using a flat-blade screwdriver, lift off the space bar. This exposes a wire, plunger, spring, center post, and two corner posts.
 - b. If necessary, remove the wire, plunger and spring.

4/Maintenance

- c. Place the spring on the center post.
- d. Place the plunger on the spring. Press on the front edge and then the back edge of the plunger to work it into place on the center post.
- e. Slide the metal wire into the corner posts so that the wire rests over the center plunger and will depress the plunger when pressed.
- f. Turning the keyboard up to view it from an angle, snap the wire in place in the two depressions beneath the hooks on the underside of the bar. Use a screwdriver to assist you in snapping the wire into place.
- g. Press down on the space bar to lock it into place.

SCREEN OVERLAY

Recommended Use

The Contrast Enhancement Overlay enhances contrast and reduces reflection from external sources.

Removing the Overlay

To remove the overlay, spread the fingers of one hand and place your hand on the screen. Close your hand slightly, allowing the friction of your fingers to pull the overlay away from the screen.

Installing the Overlay

Use the following procedure to remove the Contrast Enhancement Overlay:

1. The overlay has adhesive on both tabs on the side opposite the matte surface. Remove the backing from the adhesive.
2. With the matte surface facing out, insert one overlay tab under the center of the lip at the top of the screen.
3. Insert the other overlay tab under the center of the lip at the bottom of the screen. Hold the overlay in place with your hand.
4. Slip the side of the overlay under the lip at the left side of the screen by simultaneously running your finger along the left edge of the overlay, and sliding the overlay under the screen lip.
5. Spread the fingers of your left hand to hold the left side, top, and bottom of the overlay in place. Use your right hand to insert the overlay right edge under the right edge of the screen lip.
6. Center the overlay. Press firmly directly over the tabs of the overlay to activate the adhesive.

MONITOR ACCESS, REMOVAL, INSTALLATION TECHNIQUES

The following instructions pertain to the Monochrome Monitor used with the 9100A Programmer's Station and Monochrome Video option.

Removing the Monitor Cover

1. Disconnect the line cord from the Monitor.
2. Use a Phillips screwdriver to remove the two screws along the bottom front and the single screw at the top rear.
3. Place the Monitor face down on a flat surface. To protect the screen from scratches, the surface must be covered with a soft cloth or pad.
4. Remove the four Phillips screws securing the tilt-base assembly to the Monitor. Rotate the assembly so that the hole found in the plastic foot successively allows access to each screw.
5. Pull the plastic Monitor case up and off.
6. Replace the Monitor case by reversing these steps.

Accessing the Monitor Chassis

1. Remove the five Phillips rear panel securing screws. Do not remove the power panel.
2. Place the Monitor screen face down on a flat surface that is protected by a soft cloth or pad.
3. Swing the bottom chassis cover open. The hinge will allow the chassis cover to open to 90 degrees.
4. To close the Monitor chassis, reverse the above procedure.

Removing the Front Bezel

1. Remove the monitor cover as described above.
2. Place the monitor chassis on a flat surface, with the front bezel extended over the edge of the work surface.
3. Locate the six front bezel connector holes. The connector holes are located on each side of the metal chassis, where the plastic snaps from the bezel are inserted in the chassis.
4. Insert a flat screwdriver into each of the connector holes, and push in to disengage the front bezel snaps. Maintain an outward force on the bezel to keep the snaps disengaged.
5. Lift the front bezel away from the chassis.

6. To reinstall the front bezel, position the bezel with the bezel snap fingers in line with the connector holes. Press in evenly on the bezel until all of the front bezel fingers snap into place.



Figure 4-4. Monitor Rear Panel

Monitor Power Supply

REMOVING THE MONITOR POWER SUPPLY

WARNING

USE EXTREME CAUTION WHEN REMOVING THIS UNIT. THERE IS A DANGER OF ELECTRICAL SHOCK FROM HIGH VOLTAGE STORED IN CAPACITORS.

1. Lethal voltages may be present. Disconnect the power and wait 30 seconds before working with the power supply.
2. Open the chassis as described under the heading, "Accessing the Monitor Chassis".
3. Place the Monitor face down on a soft, level surface.
4. Disconnect the six wires that connect the power panel to the power supply. Refer to Figure 4-5 for wire locations.
5. Remove the power panel (two Phillips screws).
6. Remove the Phillips screw found in the rear corner of the Power Supply PCA.
7. Now work the Power Supply PCA loose from the three securing standoffs found in the remaining three corners.
8. Holding the Power Supply PCA in one hand, use the other hand to disconnect the power/video cable connector from the power supply. Be careful not to brush against the crt or yoke.
9. Remove the Power Supply PCA from the chassis.

NOTE

Do not discard the piece of foam that rests between the power supply and the chassis.

4/Maintenance

INSTALLING THE MONITOR POWER SUPPLY

The following installation procedure assumes that the existing Power Supply has already been removed:

1. Place the Monitor face down on a soft, level surface.
2. Install three new plastic standoffs into the square holes in the chassis top.

NOTE

Do not reuse plastic standoffs. Damage to standoffs may occur during removal without being clearly apparent. Fluke recommends that PCAs ALWAYS be equipped with new standoffs. All replacement modules are provided with new standoffs.

3. With the power/video cable connector directed toward the rear of the Monitor, connect the power/video cable to the power supply. The power/video cable connector may be fit over any two of the three sets of pins.
4. Reinsert the foam piece between the power supply and the chassis.
5. Place the power supply over the standoffs and press on the PCA to lock it in place. Install the Phillips screw in the rear corner of the pca.
6. Connect the power leads and ground. Refer to Figure 4-5 for wire connections.

NOTE

The mains wiring must not touch the secondary wiring (power/video cable). If wires touch, the unit will probably exceed conducted emissions limits. The power/video cable should be taut against the side of the chassis.

7. Replace the power panel.
8. Close the chassis cover.

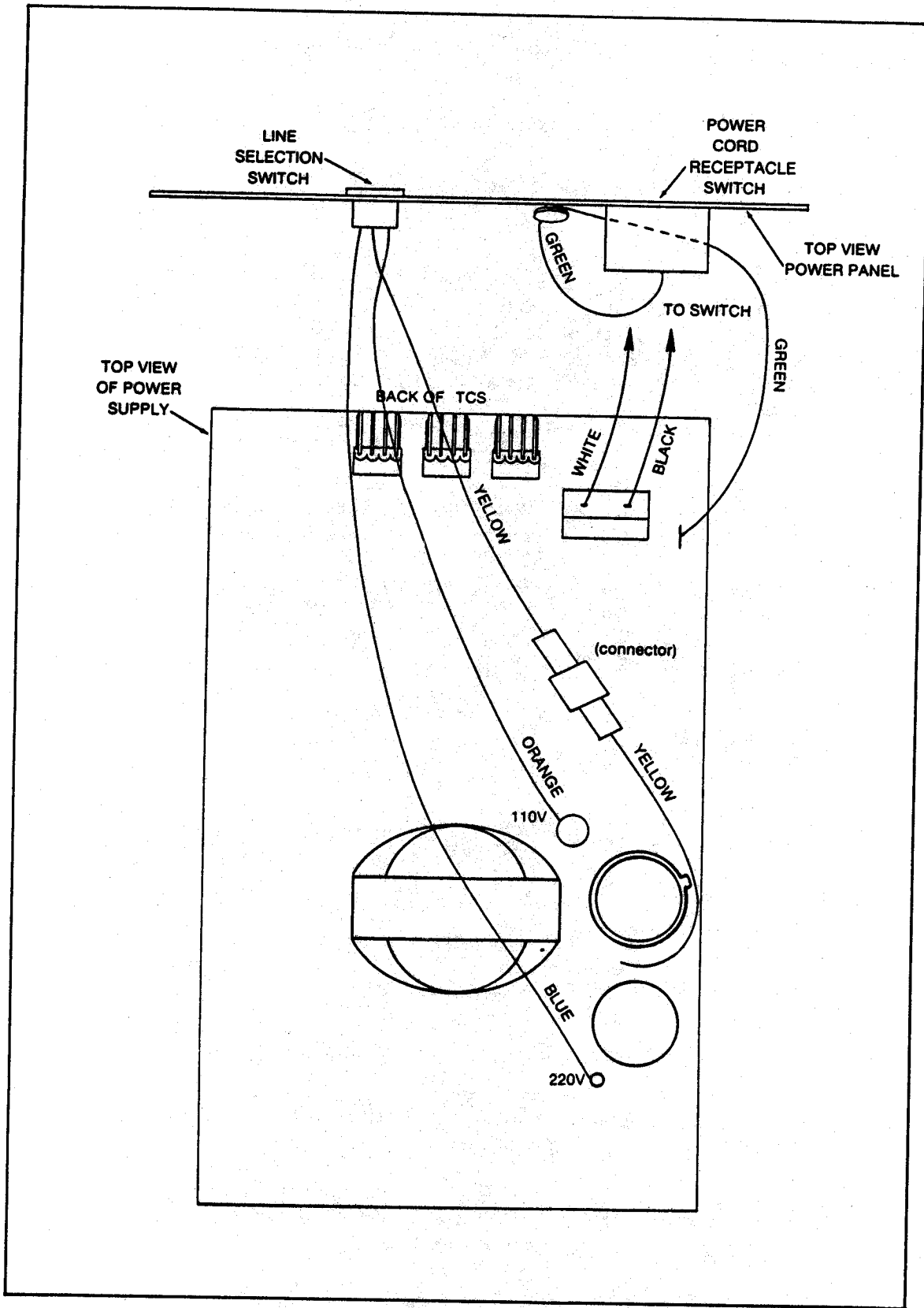

Figure 4-5. Power Supply Lead Connections

Monitor Display PCA

REMOVING THE DISPLAY PCA

NOTE

Fluke recommends replacing the crt when the Display PCA is replaced.

WARNING

TO REDUCE THE RISK OF ELECTRIC SHOCK ALWAYS TURN OFF THE TCS, DISCONNECT THE POWER CORD FROM THE PANEL ON THE REAR OF THE CHASSIS, AND WAIT ONE MINUTE BEFORE PROCEEDING WITH DISPLAY PCA REMOVAL.

WARNING

THE HIGH VOLTAGE SUPPLY MAY RETAIN A HIGH VOLTAGE CHARGE EVEN AFTER THE INSTRUMENT HAS BEEN TURNED OFF FOR SOME TIME. A CHARGE CAN BUILD UP ON THE CRT ANODE EVEN AFTER IT HAS BEEN DISCHARGED. THE CHARGE CAN DELIVER A SHOCK THAT COULD CAUSE THE CRT TO BE DROPPED, RESULTING IN AN IMPLOSION AND DANGEROUS FLYING GLASS.

1. Open the chassis as described under the heading, "Accessing the Monitor Chassis".

NOTE

Although the Display PCA uses a bleeder resistor, as a safety precaution assume that the resistor is nonfunctional.

2. Discharge the anode to the crt through a 1-megohm resistor as follows:
 - a. Connect one end of the resistor to the chassis with one clip lead.
 - b. Connect the other end of the resistor to the shaft of a 5-inch or longer screwdriver with a 1/4-inch tip, using another clip lead.
 - c. Hold the screwdriver by its plastic handle, and gently slip the tip under the edge of the anode connector on the crt end of the high-voltage lead; keep the blade flat against the glass envelope.
 - d. Slide the blade forward until the screwdriver blade touches the metallic clip at the end of the high-voltage lead. Be careful not to scratch the surface of the crt.

3. Remove the power/video cable connector from the Display PCA. Use both hands to pull the cable vertically away from the Display PCA.

Be careful not to bend the Display PCA. Refer to Figure 4-6 for the location of the power/video cable.

CAUTION

Bending the Display PCA can break solder joints and result in unreliable operation.

4. Working from the chassis exterior, remove the five standoff-securing screws for the Display PCA.
5. Locate the single black ground wire that attaches to the crt mounting bracket in the upper corner of the chassis. Pull the ground wire off the tab in the mounting bracket.
6. Gently pull the crt socket away from the end of the crt.
7. Disconnect the yoke wire connectors from the Display PCA.
8. Use a side-to-side motion to pry the anode on the crt loose from the anode connector. If necessary, use a non-conductive tool to help disengage the connector.
9. Remove the four PCA standoffs.
10. Remove the Display PCA with the anode and drive wires attached.

INSTALLING THE DISPLAY PCA

NOTE

Fluke recommends replacing the crt when the Display PCA is replaced.

WARNING

TO REDUCE THE RISK OF ELECTRIC SHOCK ALWAYS TURN OFF THE 9100A/9105A, DISCONNECT THE POWER CORD FROM THE PANEL ON THE REAR OF THE CHASSIS, AND WAIT ONE MINUTE BEFORE PROCEEDING WITH DISPLAY PCA INSTALLATION.

1. Open the chassis as described under the heading, "Accessing the Monitor Chassis".
2. Use a Phillips screwdriver to remove the two screws on the power panel. Disconnect the six wires that connect the power panel to the power supply. Refer to Figure 4-5 for wire locations. Remove the power panel.
3. Install the Display PCA using four standoffs. Be careful not to bend the Display PCA.

CAUTION

Do not bend the Display PCA. Doing so can break the solder joints and result in unreliable operation.

4. Replace the power/video cable connector in the Display PCA.
5. Snap the anode connector to the top of the crt.
6. Reattach the crt neck connector to the top of the neck of the crt. The connector is keyed to the pins.
7. Reconnect the yoke connectors.
8. Reattach the black ground wire to the tab on the crt mounting bracket beneath the X-ray warning on the chassis.
9. Reconnect the six wires that connect the power panel to the power supply. Refer to Figure 4-5 for wire locations. Replace the power panel.
10. Close the chassis cover as described under the heading, "Accessing the Monitor Chassis".

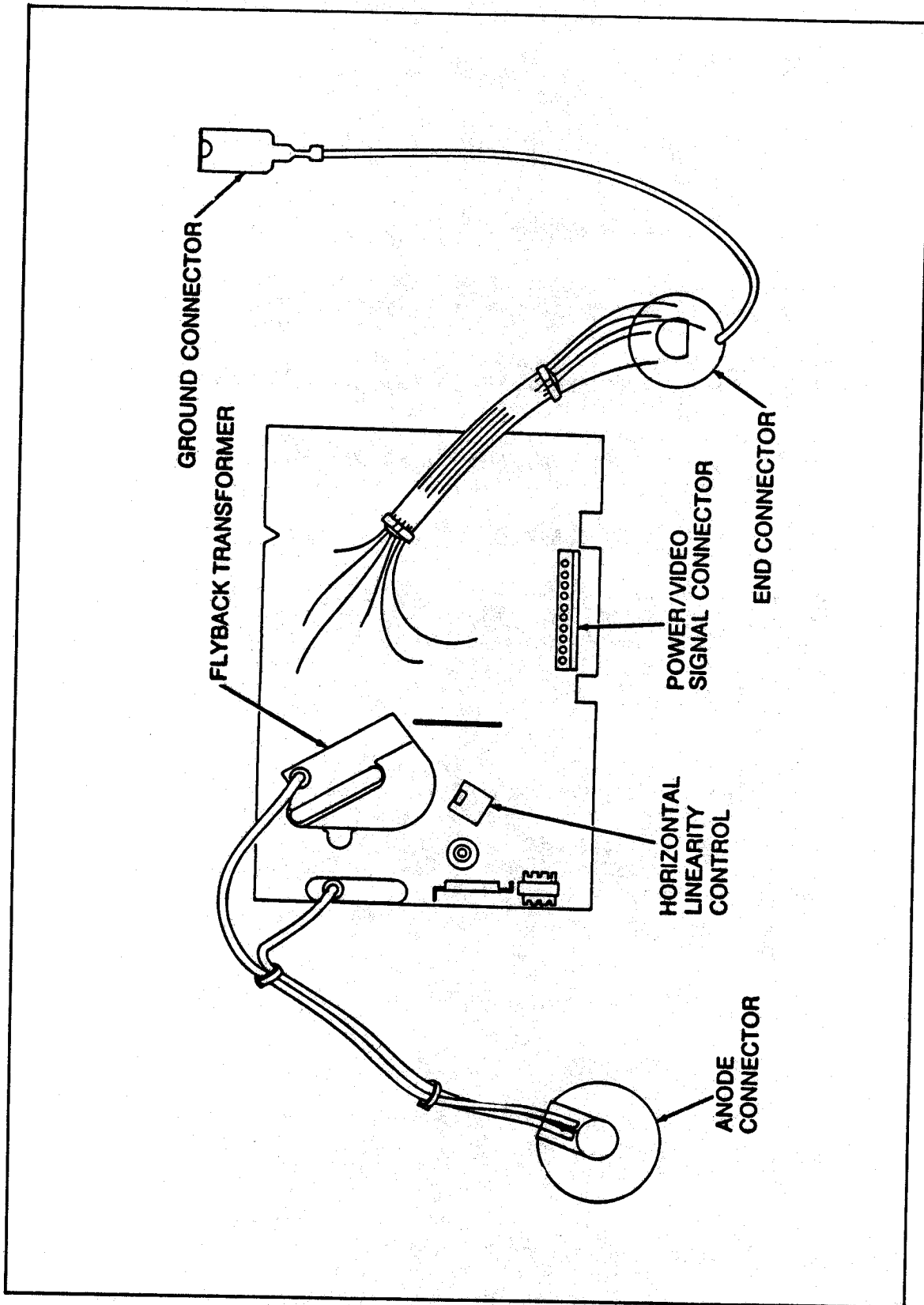

Figure 4-6. Display PCA

4/Maintenance

Crt and Yoke

REMOVING THE CRT AND YOKE

NOTE

Fluke recommends replacing the Display PCA when the crt is replaced.

WARNING

TO AVOID INJURY, USE CAUTION WHEN HANDLING THE CRT. WEAR PROTECTIVE CLOTHING AND SAFETY GLASSES OR A FULL FACE SHIELD. AVOID STRIKING THE CRT ON ANY OBJECT THAT MIGHT CAUSE IT TO CRACK OR IMplode. NEVER HANDLE THE CRT IN AN UNSAFE AREA, SUCH AS ONE WITH WET FLOORS OR HIGH ACTIVITY. NEVER HANDLE THE CRT AROUND OTHERS WHO MAY NOT BE PROPERLY PROTECTED. AVOID SCRATCHING THE TUBE OR CAUSING OTHER DAMAGE DURING INSTALLATION.

WARNING

TO REDUCE THE RISK OF ELECTRIC SHOCK ALWAYS TURN OFF THE 9100A/9105A, DISCONNECT THE POWER CORD FROM THE PANEL ON THE REAR OF THE CHASSIS, AND WAIT ONE MINUTE BEFORE PROCEEDING WITH CRT AND YOKE REMOVAL.

WARNING

THE HIGH VOLTAGE SUPPLY MAY RETAIN A HIGH VOLTAGE CHARGE EVEN AFTER THE INSTRUMENT HAS BEEN TURNED OFF FOR SOME TIME. A CHARGE CAN BUILD UP ON THE CRT ANODE EVEN AFTER BEING DISCHARGED. THE CHARGE CAN DELIVER A SHOCK THAT COULD CAUSE THE CRT TO BE DROPPED, RESULTING IN AN IMPLOSION AND DANGEROUS FLYING GLASS.

1. Discharge the anode to the crt through a 1-megohm resistor as follows:
 - a. Connect a resistor end to the chassis with clip lead.
 - b. Connect the other end of the resistor to the shaft of a 5-inch or longer screwdriver with a 1/4-inch tip, using another clip lead.
 - c. Hold the screwdriver by its plastic handle, and gently slip the tip under the edge of the anode connector on the crt end of the high-voltage lead; keep the blade flat against the glass envelope. Slide the blade forward until the screwdriver blade touches the metallic clip at the end of the high-voltage lead. Be careful not to scratch the surface of the crt.

2. Disconnect and remove the Display PCA as follows:
 - a. Gently pull the crt socket away from the end of the crt.
 - b. Disconnect the yoke wire connectors from the Display PCA.
 - c. Use a side-to-side motion to pry the anode on the crt loose from the anode connector. If necessary, use a non-conductive tool to help disengage the connector.
 - d. Remove the four pca standoffs.
 - e. Remove the Display PCA with the anode and drive wires attached.
3. Use a Phillips screwdriver to remove the two screws on the power panel.
4. Disconnect the six wires that connect the power panel to the power supply. Refer to Figure 4-5 for wire locations. Lift off the power panel.
5. Remove the front bezel (see "Removing the Front Bezel", earlier in this section.)
6. Use a Phillips screwdriver to remove the eight outside screws from the four crt mounting brackets. Remove the tab from the crt mounting bracket at the corner of the crt.
7. Remove the dust gasket.
8. With the crt face down (on a soft, level surface), lift the chassis off the crt. Be careful not to scratch any part of the crt!
9. Place the crt on a soft, level surface.

INSTALLING THE CRT AND YOKE

NOTE

Fluke recommends replacing the Display PCA when the crt is replaced.

WARNING

TO AVOID INJURY, USE CAUTION WHEN HANDLING THE CRT. WEAR PROTECTIVE CLOTHING AND SAFETY GLASSES OR A FULL FACE SHIELD. AVOID STRIKING THE CRT ON ANY OBJECT THAT MIGHT CAUSE IT TO CRACK OR IMplode. NEVER HANDLE THE CRT IN AN UNSAFE AREA, SUCH AS ONE WITH WET FLOORS, HIGH ACTIVITY, ETC. NEVER HANDLE THE CRT AROUND OTHERS WHO MAY NOT BE PROPERLY PROTECTED. AVOID SCRATCHING THE TUBE OR CAUSING OTHER DAMAGE DURING INSTALLATION.

WARNING

TO REDUCE THE RISK OF ELECTRIC SHOCK ALWAYS TURN OFF THE 9100A/9105A, DISCONNECT THE POWER CORD FROM THE PANEL ON THE REAR OF THE CHASSIS, AND WAIT ONE MINUTE BEFORE PROCEEDING WITH CRT AND YOKE INSTALLATION.

WARNING

THE HIGH VOLTAGE SUPPLY MAY RETAIN A HIGH VOLTAGE CHARGE EVEN AFTER THE INSTRUMENT HAS BEEN TURNED OFF FOR SOME TIME. THE CHARGE CAN DELIVER A SHOCK THAT COULD CAUSE THE CRT TO BE DROPPED, RESULTING IN AN IMplosion AND DANGEROUS FLYING GLASS.

The Display PCA and power panel must be removed prior to crt installation.

1. With the crt face down on a soft, level surface and the anode facing away from you, loosely install the four crt brackets to the four crt mounting ears and crt grounding clip (step 2).

CAUTION

Do not move the magnets on the crt yoke.

2. Insert the crt grounding clip under the screw on your right, closest to you. Insert the ground wire tab into the clip.
3. Carefully insert the chassis over the crt with the anode connection on the crt positioned toward the top of the unit.

4. Use a Phillips screwdriver to install and loosely tighten the eight exterior screws on the four crt mounting brackets.
5. Approximately center the crt. Use a long-bladed screwdriver to tighten the four screws that attach the crt to the crt mounting bracket.
6. Push the crt as far forward as possible into the chassis and tighten the exterior screws.
7. Clean the crt with alcohol or another suitable cleaner.
8. Reinstall the Display PCA as described above.
9. Reinstall the dust gasket.
10. Reinstall the front bezel.
11. Reconnect the six wires that connect the power panel to the power supply. Refer to Figure 4-5 for wire locations. Reinstall the power panel by replacing the two screws.
12. Perform the procedure under the heading "Monitor Adjustment."
13. Close the chassis cover.

MONITOR ADJUSTMENT

NOTE

Display tilt may be slightly affected by the orientation of the Monitor, especially in environments containing a high density of metal. Rotate the unit and try to find a position where the tilt is in the center between extreme clockwise tilt and extreme counterclockwise tilt. Perform alignment and adjustment in that position. If no difference is perceived between the two extremes, proceed in the most convenient orientation.

NOTE

Magnetic alignment is accomplished with alignment magnets. Magnets should not be removed or added to the crt yoke. The displays are prealigned. Due to handling, however, a magnet may be rotated off position. Rotate the magnets to improve alignment **ONLY IF ABSOLUTELY NECESSARY**. It should not be necessary to use the centering rings on the yoke to align the display.

CAUTION

Turning the Monitor on with line voltage higher than 132V ac when the line voltage selection switch is in the 110 position will damage the power supply. If the voltage is set for 180 to 264V and 90 to 132V is applied, the unit may not operate.

NOTE

Allow the Monitor to warm up for at least 10 minutes. During the first 5 minutes of operation, raster lines may be visible on the display. This is common to crt displays and is not a fault.

The display can be adjusted using a program-generated monitor alignment pattern. The pattern consists of four outlined boxes, two across and two down. Each box is 40 characters wide by 12 lines high. Table 4-3 contains the required monitor alignment program. An alignment pattern can also be generated by a program on the 9100A Service Utility disk, which is part of the 9100A Service Kit (see Troubleshooting).

This program is used with the Alignment Template, P/N 777144. When the display is properly adjusted, the four boxes displayed by the program fit evenly and symmetrically within the inner lines of the template.

Table 4-3. Monitor Alignment Program

 program alignment

```

*****
!* This program generates an alignment pattern on the monitor. The *
!* pattern consists of four outlined boxes, two across and two down; *
!* each box is 40 characters wide and 12 lines high. *
*****

HL9 = "\8A"+" \8A"+" \8A"+" \8A"+" \8A"+" \8A"+" \8A"+" \8A"+" \8A" ! 9 horiz. lines
Top_s = "\86"+" \8A"+ HL9 + HL9 + HL9 + HL9 +" \8A"+" \8C" ! top of box string
Bot_s = "\83"+" \8A"+ HL9 + HL9 + HL9 + HL9 +" \8A"+" \89" ! bottom of box string
Ctr_s = "\85" ! center of box string
EoS_s = "\1B[2;30H Monitor \1B[4C Alignment \1B[10B" ! End of Screen string
L12_s = "" ! Line 12 string

open device "/term2", as "output" ! open channel to print to monitor

print using "\1B[H\1B[J" ! cursor to top left, and clear monitor screen

loop for s = 0 to 1 ! do top half and then bottom half of pattern
  print Top_s,Top_s ! print top line of left and right boxes
  loop for l = 2. to 11.
    print Ctr_s,Ctr_s ! fill in center of left and right boxes
  end loop
  if s > 0 then L12_s = EoS_s ! if this is the End of the Screen, then
    ! need to print title and position cursor.
  print Bot_s,Bot_s,L12_s ! print bottom line of left and right boxes

end loop ! if this was the top half, do the bottom

end program

```

Alternately, any monitor display pattern can be used when the programmed pattern is not available. This method involves display and adjustment of the monitor screen for a centered display of the correct size. The alternate pattern used must measure 80 columns wide by 24 rows high to allow for correct adjustment.

The monitor display is adjusted using the following seven controls:

- o Vertical Linearity
- o Vertical Size
- o Brightness
- o Focus
- o Horizontal Phase
- o Horizontal Size
- o Horizontal Linearity
- o Contrast

The first six of these controls can be adjusted externally through holes in the monitor chassis (shown in Figure 4-7). Adjusting horizontal size requires hex adjustment tool (P/N 572321). Contrast is an external operator adjustment. Adjusting all other controls requires the use of an adjustment tool (P/N 800540).

The monitor chassis must be opened to adjust the Horizontal Linearity control. Refer to "Accessing the Monitor Chassis". Adjusting the Horizontal Linearity control requires the use of the hex adjustment tool (P/N 572321).

As some adjustments may interact with others, repeating the procedure may be necessary. For either display method, use the following steps to adjust the display:

1. If necessary, remove the monitor cover. Then, locate the external display adjustment holes. See Figure 4-7.
2. Cover a flat surface with a soft cloth to protect the monitor screen. Place the Monitor face down.
3. Open the Monitor by using a Phillips screwdriver to remove the five screws on the rear panel. Swing the bottom chassis cover down. Do not remove the power panel.

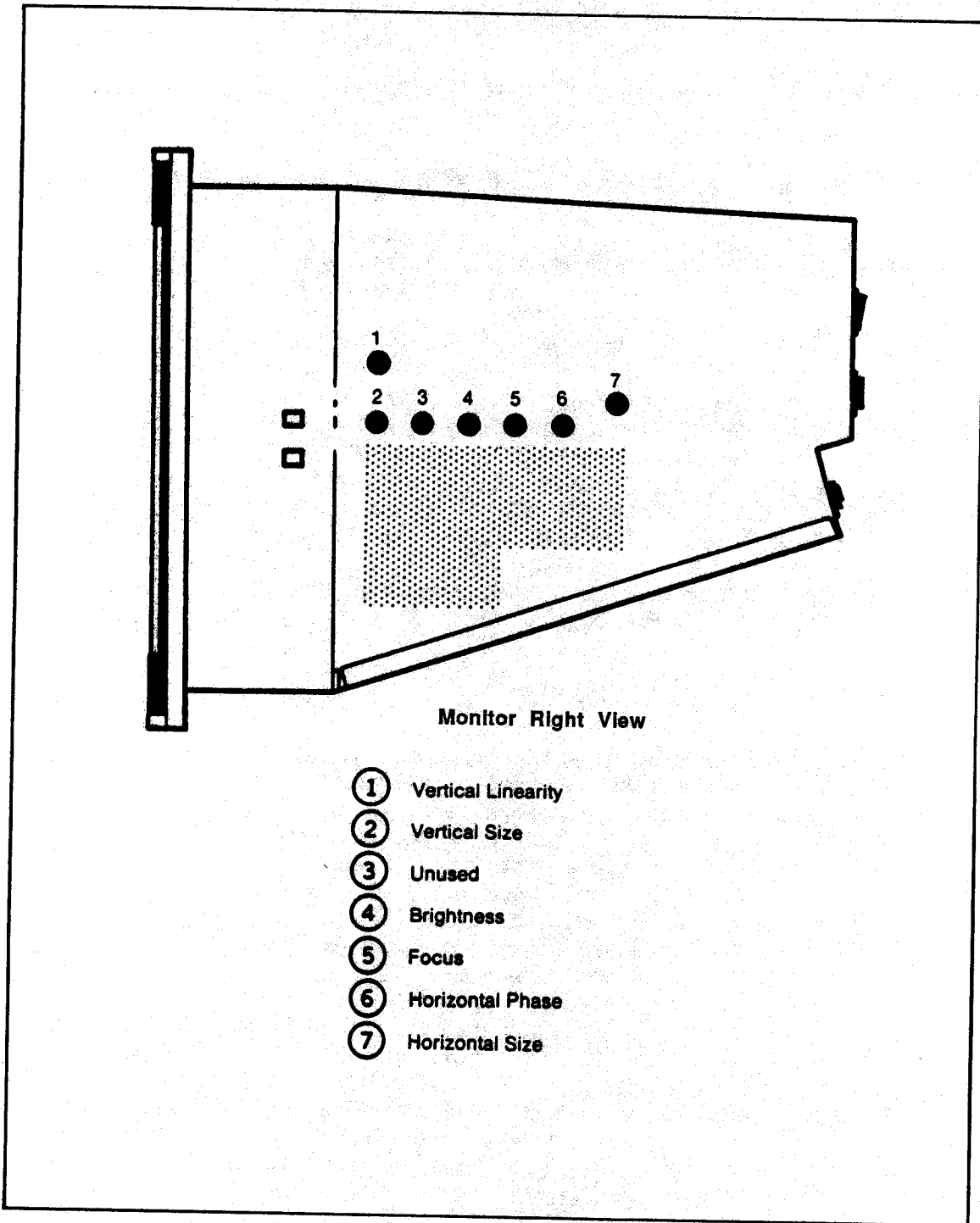

Figure 4-7. External Display Adjustment Locations

4/Maintenance

4. Perform the following yoke adjustment only if the screen appears tilted.
 - a. Loosen the clamp around the yoke of the crt using a 3/16-inch nut driver.
 - b. Turn the Monitor so that the display can be seen.
 - c. Rotate the yoke slightly to adjust for the screen tilt.
- d. Check that the tightening screw is easily accessible, then tighten the clamp to a torque of 6 inch-pounds (0.678 n-m). Do not overtighten the screw, or the neck of the crt may crack.

WARNING

TO AVOID INJURY, USE CAUTION WHEN HANDLING THE CRT. WEAR PROTECTIVE CLOTHING AND SAFETY GLASSES OR A FULL FACE SHIELD. AVOID STRIKING THE CRT ON ANY OBJECT THAT MIGHT CAUSE IT TO CRACK OR IMplode. NEVER HANDLE THE CRT IN AN UNSAFE AREA, SUCH AS ONE WITH WET FLOORS, HIGH ACTIVITY, ETC. NEVER HANDLE THE CRT AROUND OTHERS WHO MAY NOT BE PROPERLY PROTECTED. AVOID SCRATCHING THE TUBE OR CAUSING OTHER DAMAGE DURING INSTALLATION.

NOTE

Display tilt may be slightly affected by the orientation of the Monitor, especially in environments containing a high density of metal. Rotate the unit and try to find a position where the tilt is in the center between extreme clockwise tilt and extreme counterclockwise tilt. Perform alignment in that position. If no difference is perceived between the two extremes, proceed in the most convenient orientation.

5. Locate the Horizontal Linearity control on the Display PCA (see Figure 4-7.) Adjust Horizontal Linearity so that the left half of the display is the same size as the right half of the display. Since the open chassis cover has a slight effect on Horizontal Linearity, close the chassis cover to verify Horizontal Linearity and keep it closed for the remainder of the procedure. Linearity is also slightly affected by the unit being upside down.

6. Adjust Horizontal Phase to line up the center gaps between the boxes with the alignment centering marks on the bezel. If an alternate pattern is being used, use Horizontal Phase to center the display.
7. Adjust Vertical Linearity so that the boxes (or regions of the alternate pattern) appear the same.
8. Adjust Vertical Size to make the alignment pattern (or alternate pattern) about 5 1/8 inches (130 mm) high.
9. Adjust Horizontal Size to make the alignment pattern (or alternate pattern) about by 7 3/4 inches (195 mm) wide.
10. Set the Brightness control for a slight amount of "blooming" with the Contrast (external operator control) set to maximum.
11. Adjust the Focus control with Contrast set for normal viewing.
12. Use a Phillips screwdriver to replace the five rear panel screws.

NOTE

If the Monitor was adjusted with the unit upside down, a final Horizontal Phase adjustment will probably be necessary.

13. Reinstall the monitor cover.

DECIDING ON CRT REPLACEMENT

The crt should be replaced if any of the following occur:

- o If an image has been burned into the phosphor and the image on the display is unacceptably altered.
- o If scratches are detectable by a pass of the finger. (Scratches can create a safety hazard that lessens the ability of the crt to withstand implosion.)

The crt may require replacement when any of the following occur:

- o Ghost images appear on the display.
- o Brightness levels are unacceptable.

NOTE

Insufficient brightness can be caused by several factors. After 10,000 hours of continuous excitation of the phosphor, crt brightness can be expected to have dropped by approximately 50 percent. Failures in the Display PCA can also cause loss of brightness.

4/Maintenance

A properly functioning crt requires ten minutes to warm up completely. During the first five minutes, raster lines may appear on the display. This is common to crt displays and is not a fault. If the display takes more than five minutes to achieve full brightness, suspect either a crt or Display PCA failure.

NOTE

Monitors are preset at the factory for the same brightness at maximum contrast. Due to crt variations, the Display PCA brightness control will not be in the same position for all units and the raster may be visible for varying amounts of time, if at all.

NOTE

Because the maximum brightness of the crt will vary from unit to unit, the decision to replace a display on the basis of insufficient brightness is subjective.

SELF TEST ROUTINES

Power-Up Self Test

At power-up, the 9100A/9105A sequences through a series of self tests. A display response is presented for any test that fails. These responses (and related meanings) are presented in Table 4-4. In addition, a Mainboard ROM and Display Response test is run. A failed test in this instance is evidenced by simultaneously flashing RUN UUT and DISK ACCESS LEDs.

Probe Self Test

The Probe Self Test verifies that the Probe is connected and is communicating with the system. Use the following procedure:

1. Press the MAIN MENU key.
2. Press the left arrow (<-->) key until the cursor rests on the first (left-most) field. Then, with the cursor on this field, press the SELFTEST key.
3. Press the right arrow (-->) key to move the cursor to select the next field, then press the PROBE key. Check that the display reads:

MAIN: SELFTEST PROBE
4. Press the ENTER key to initiate the self test.
 - o If the self test fails, a failure message is displayed. Check the probe connection and repeat the test.
 - o If the test fails a second time, the Probe requires service.

Table 4-4. Power-Up Self Test Responses

selftest: testing memory . . .

This message is displayed during the simple read/write test of the RAM.

-----Press any key to continue test-----
or the RESET key for the next test

If an error was detected during the RAM test, pressing the RESET key aborts the RAM test and sequences the 9100A/9105A to the next test in the power-up self test series. Pressing any other key continues the test at the next higher RAM location.

selftest: ram read/write error @

A RAM read/write test has failed at the specified address. The memory test itself is extremely primitive. A long word with a value of '5a5a5a5a' is written and read back, followed by a long word with the value 'a5a5a5a5'. Any bit that cannot be written either high or low is considered defective.

selftest: r/w error on pod cmd port:

Of the command bits that are tested on the pod port, one or more have failed a read/write test. The mask of the failing bit(s) is displayed in hex.

selftest: r/w error on pod data port:

One or more bits in the pod data port have failed a read/write test. An error mask of the offending bit(s) is displayed in hex.

**selftest: data error in uart u7
should be: xxxx not: xxxx**

An error occurred while the UART was in its digital loopback self-test mode. The data written has not matched the data read in device U7, and the two datum are displayed on the second line of the display.

**selftest: data error in uart u12
should be: xxxx not: xxxx**

An error occurred while the UART was in its digital loopback self-test mode. The data written has not matched the data read in device U12, and the two datum are displayed on the second line of the display.

selftest: timed out waiting for uart

One of the UART transmit registers has not cleared in a reasonable amount of time. The UART clock could be disabled, or the chip itself could be bad.

Table 4-4. Power-Up Self Test Responses (cont)

selftest: probe i/o board not responding

A simple read/write test to both of the gate array chips on the Probe I/O PCA has failed.

selftest: ram test bus error@

An unexpected bus error occurred during the power up RAM test. This could be a result of setting the RAM size in the EEPROM too large, or it could be a problem with the memory decoding circuitry.

selftest: front display not responding

The front panel display processor has not returned the expected character within a reasonable amount of time.

selftest: probe i/o stop counter failure

The high speed stop counter in the start-stop logic has failed. To test the stop counter on the Probe I/O PCA the counter is soft clocked and checked for proper response. The counter is preset to a value of two. The clock is soft stepped once and the stop counter is checked to insure it has not triggered. Another clock is produced and the stop counter is checked for an active condition.

selftest: probe i/o logic chip inactive

In the process of setting up the stop counter test, it is necessary to set the start-stop state machine inside the U19 gate array to state 1 (start received, waiting for stop). If the state machine is not in state 1 after clocking, an error is assumed somewhere in the start-stop logic subsection.

selftest: floppy controller failure

A simple read/write test to several of the floppy controller registers has failed.

selftest: floppy controller not responding

A bus error occurred while trying to read or write the floppy controller.

Table 4-4. Power-Up Self Test Responses (cont)

selftest: stuck vector:

The floppy controller is given a force interrupt command. If the resultant vector is not the floppy controller interrupt vector, then it is assumed that another interrupt is active. At this point in the self test, no interrupts should be active, and this is considered an error. The force interrupt command is followed by a reset interrupt command. After this command no interrupts should be active, and any active interrupts are again considered error conditions. In both conditions the number reported is the actual physical vector address.

selftest: uarts not responding

A bus error occurred while trying to read or write either of the UART devices.

selftest: front display ram test failure

An error code was returned by the front panel display when asked to perform an internal RAM test.

Pod Self Test

This test performs a comprehensive pod check. Test failure is evidenced by an error message. (See the respective pod manual for full error descriptions). Proceed as follows:

1. Make all connections. Ensure that the Pod is attached to the mainframe and that the pod UUT connector is inserted and locked into the pod self-test socket. The pod manual and the 9100A/9105A Getting Started guide illustrate these connections further.
2. On the 9100A/9105A, first press MAIN MENU, then move the cursor to the first (left-most) field using the left arrow (<--) key.
3. Press the SELFTEST key.
4. Move the cursor one field to the right and press POD. Check that the display reads:

MAIN: SELFTEST POD
5. Press ENTER to initiate the self test.
 - o If the self test fails, a failure message is displayed. Check the pod connection and repeat the test.
 - o If the test fails a second time, the Pod requires service.

4/Maintenance

I/O Module Self Test

The I/O Module Self Test verifies that the I/O Module is connected and is communicating with the system. Use the following procedure:

1. Press MAIN MENU, then move the cursor to the first (left-most) field using the left arrow (<--> key).
2. Press SELFTEST.
3. Move the cursor one field to the right and press I/O MOD.
4. Move the cursor one more field to the right, and press the number of the I/O Module to be tested. Check that the display reads:

```
MAIN: SELFTEST I/O MOD <n>
```

(where <n> signifies the number of the I/O Module)

5. Press ENTER to initiate the self test.
 - o If the self test fails, a failure message is displayed. Check the I/O Module connection and repeat the test.
 - o If the test fails a second time, the I/O Module requires service.

Display Self Test

Several software tests aid in testing the Display Board. Each test can be selected by a command sent through the display processor serial port. The "Test" command, 0x0e, followed by a test number ascii 1-9 (or 0x31-0x39) selects the test.

The tests are available through a program in the 9100A Service Kit. They can also be initiated using a 68000 Pod plugged into the mainframe. The Pod must initialize the DUART before sending the serial command to the Display Board. These tests are not available through TL/1; the Control N (0x0e) command is not sent to the display.

Tests 1 (ROM) and 2 (RAM) are also performed by mainframe software during the mainframe self test following a reset. At this time, the mainframe also performs Test 9 (look for Synchronous Special Function key) to determine if a boot should be forced off the floppy drive instead of the hard disk.

Tests 4, 5, and 6 are useful for troubleshooting the keyscan and display refresh hardware. They are available by grounding Test Point 6 (TP6) during a reset, as well as by software control.

All display tests are listed and described in Table 4-5.

Table 4-5. Display Self Test

Test 0 - Sends Out Software Revision Number

The number is returned to the serial port just like a key press.

Test 1 - Verifies ROM Internal Checksum

Returns 0x70 (p) to the serial port if test passed, 0x71 (q) if it didn't.

Test 2 - Performs Quick RAM Test

This is a non-destructive test of the Display RAM. It writes the compliment of the present data, reads it back, re-writes the original data, and then reads that back. Returns 0x72 (r) to the serial port if the test passed, 0x73 (s) if it didn't.

Test 3 - Performs Long RAM Test

This is a more complete, destructive test of the Display RAM. It performs a test similar to the 9100 RAM FAST on the RAM and returns 0x74 (t) to the serial port if the test passed, or 0x75 (u) if the test did not pass.

NOTE

Tests 4, 5, and 6 cause the software to exit mainframe control. The Display Board does not respond to further commands or data until the test is exited by keyboard control or by a reset. All three tests are destructive, in that they write over the present display.

Also, tests 4, 5, and 6 can be accessed by grounding the TEST testpoint and resetting (or powering on) the display.

Test 4 - Jump to Key Test Routine

This is the mode entered when TP6 is grounded during a reset. This test displays the row and column of the key being pressed on the display.

The RESET key causes this test to terminate and Test 5 to start.

Table 4-5. Display Self Test (cont)

Test 5 - Jump to Display Lines Routine

The following key-pattern relationships are applicable during this test:

- o Keys 1, 2, and 3 each display a vertical bar in every third column. For example, key 1 display bars in columns 1, 4, 7, and so on. Keys 2 and 3 control columns beginning at 2 and 3, respectively.
- o Keys 4, 5, and 6 display a series of horizontal bars, also spaced three lines apart.
- o Key 0 turns all lines off (blank display).
- o Key 7 turns all lines on and is the default when test 5 is entered.

NOTE

This mode is useful if the display has a "burned in" problem. Since this mode does not time out, leaving the display in this mode overnight makes for a more even display.

- o The EXEC Key returns to Test 4.
- o The ALPHA Key jumps to Test 6.
- o The RESET Key exits these tests entirely and returns the display to mainframe control.

Test 6 - Jump to V-H Lines Routine

This routine identifies the bad grid drivers or row drivers. The arrow keys are used to move among the displayed cross hairs. Pressing the HELP key displays the names of the two grids and one row driver which should be on to illuminate the dot at the intersection of the cross hairs. The RESET Key returns to Test 5.

Test 7 - Unlock Keyboard

If the keyboard has been locked by test 8, this command re-enables the key scan. It returns 0x76 (v) as an acknowledge byte.

Table 4-5. Display Self Test (cont)

Test 8 - Lock Keyboard

This command disables key scan and prevents the display board from sending any key press information. It is used by the mainframe to ensure that only test routine data is received. It returns 0x77 (w) as an acknowledge byte.

Test 9 - Report Synchronous Special Function Key

This function returns a 0x79 (y) if the processor has seen the special function key press since the last inquiry or reset. It returns a 0x78 (x) if it has not seen it. The Special function results from the SOFT KEYS, F2, and F4 keys being pressed simultaneously.

CALIBRATION

Individual level and time delay variations associated with the Probe, I/O Module, and Pod can be compensated for with the calibration adjustments presented in the following paragraphs. The following six calibrations are covered:

- o Probe offset correction calibration
- o Probe compensation calibration
- o Probe to external clock module calibration
- o Probe to Pod calibration
- o I/O Module external calibration
- o I/O Module to Pod calibration

The calibrations listed above fall into three categories. Offset correction calibration stores a correction value in non-volatile memory. Compensation calibration matches impedances. Data against clock delay calibration, performed in software, ensures that both data and the signal clocking the data arrive at the receiving hardware at the same time.

Probe compensation remains stable and is necessary only when a Probe is first connected to the mainframe. The software calibration procedures are intended to be performed by the system operator and do not require any test equipment.

4/Maintenance

10. You may have to repeat steps 8 and 9, probing at different locations each time. When calibration is complete, the display should read:

MAIN: CALIBRATION COMPLETE

11. Repeat steps 5 through 10 for each SYNC mode in which the 9100A/9105A is to be operated.

I/O MODULE TO EXTERNAL

This procedure calculates the proper setting for the I/O Module's internal clock delay for use whenever the SYNC I/O MOD TO EXT command is entered. This calibration requires the use of the Calibration Module supplied with the I/O Module. To perform the calibration:

1. Press the MAIN MENU key, and use the left arrow key to move the cursor to the left-most field.
2. Press the CAL softkey.
3. Move the cursor to the next field, and press the I/O MOD softkey.
4. Move the cursor to the next field, and press the EXT softkey. The display should read:

MAIN: CAL I/O MOD TO EXT

5. Press the ENTER key. The display should read:

MAIN: CAL I/O MOD TO EXT
INSTALL CAL HEADER IN DESIRED I/O MODULE
PRESS BUTTON WHEN READY

6. Fit the Calibration Module over the I/O Module to be tested.
7. Press the ready button on the Calibration Module. When the calibration is complete, the BUSY light should go off, and the display should read:

MAIN: CALIBRATION COMPLETE

I/O MODULE TO POD

This procedure calculates the proper settings for the I/O Module's internal clock delay for use with the SYNC I/O MOD TO EXT and the SYNC I/O MOD TO POD commands. When either is entered, the appropriate delay is selected. This calibration procedure requires use of the Calibration Module. Perform the calibration as follows:

1. Connect the Pod to a UUT.
2. Press the MAIN MENU key, and use the left arrow key to move the cursor to the left-most field.

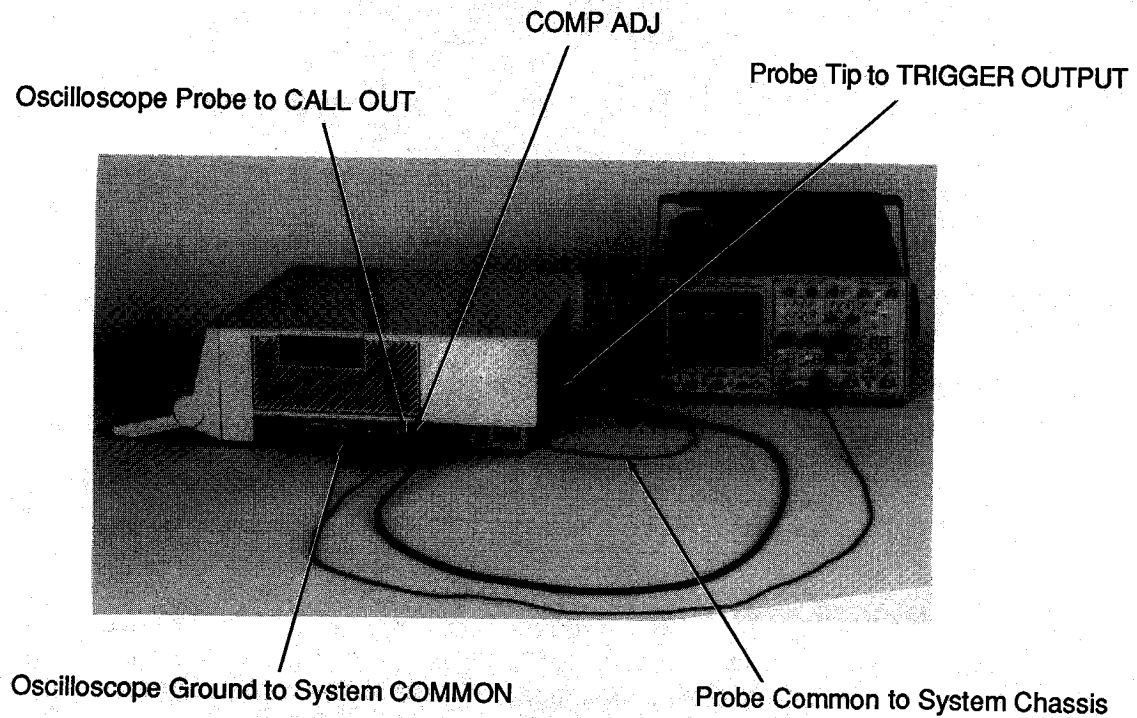

Figure 4-8. Oscilloscope Use in Probe Compensation

7. Press the ENTER key. The display should read:
 MAIN: CAL PROBE COMP
 CONNECT PROBE TO TRIGGER OUTPUT
 ADJUST COMP, PRESS STOP WHEN DONE
8. Insert the probe tip into the central (innermost) conductor of the TRIGGER OUTPUT at the rear of the 9100A/9105A. Leave the Probe in this position.
9. Adjust the oscilloscope's horizontal and vertical settings until an approximate square wave is displayed. Then use an adjustment tool on COMP ADJ to obtain an underdamped square wave with 10% overshoot. For the adjustment tool, use Fluke Part Number 800540. The square wave should bear similarity to Figure 4-9.
10. When you have finished the square wave adjustment, press the STOP key on the operator's keypad. The display should read:
 MAIN: CALIBRATION COMPLETE

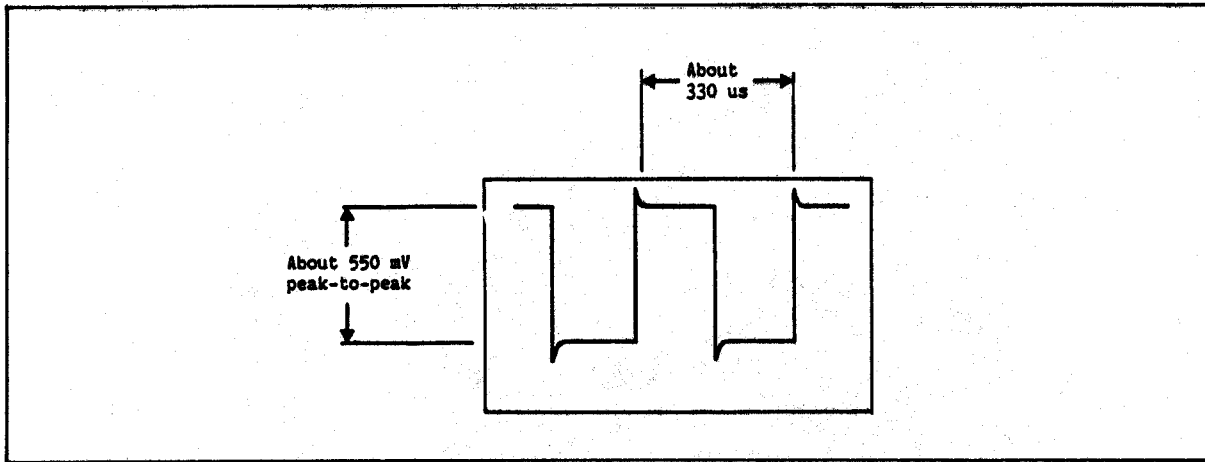

Figure 4-9. Probe Compensation Square Wave

Software Calibration

The Probe Compensation adjustment and the Probe Offset Calibration are the only hardware calibrations required for the 9100A/9105A. All other calibration is performed in software and is lost if the system is turned off, restarted, or reset. The software calibration data can be saved on disk and restored from disk to recalibrate the system. However, the restored calibration data must only be used with the system on which the calibration was performed. Any change in system hardware (Interface Pod, I/O Module(s) Clock Module, or Probe) requires system recalibration; the resulting new calibration data should be saved.

All of the software calibration procedures are intended to be performed by the system operator and do not require test equipment. Pod-related calibration procedures require the use of a known good Unit Under Test (UUT).

PROBE TO EXTERNAL (CLOCK MODULE)

This calibration automatically calibrates the Probe's internal data delay to the external clock delay. The clock signal input is through the Clock Module, which must be connected to the system. Perform the calibration as follows:

1. Press the MAIN MENU key, and use the left arrow key to move the cursor to the left-most field.
2. Press the CAL softkey.
3. Move the cursor to the next field, and press the PROBE softkey.
4. Move the cursor to the next field, and press the TO EXT softkey. The display should read:

MAIN: CAL PROBE TO EXT

5. Press the ENTER key. The display should read:

MAIN: CAL PROBE TO EXT
CONNECT EXTERNAL CLOCK TO PROBE TIP AND
COMMON LINES TOGETHER. PRESS BUTTON.

6. Connect the Probe to the Clock Module CLOCK line.
7. Connect the probe ground clip to the Clock Module COMMON line.
8. Press the probe ready button (side of Probe). The display should read:

MAIN: CALIBRATION COMPLETE

PROBE TO POD

This procedure automatically calibrates the Probe's internal data delay to the Pod's PodSync line, which the system sometimes uses as a clock signal. Use the following steps to perform the calibration:

1. Connect the Pod to a UUT.
2. Press the MAIN MENU key, and use the left arrow key to move the cursor to the left-most field.
3. Press the CAL softkey.
4. Move the cursor to the next field, and press the PROBE softkey.
5. Move the cursor to the next field, and press the TO POD softkey. The display should read:

MAIN: CAL PROBE TO POD ADDR

The last field is pod dependent and softkey selectable.

6. Press the ENTER key. The display asks you to probe the UUT at a point where the selected PodSync appears. The message is pod dependent, a possible example being:

MAIN: CAL PROBE TO POD ADDR
CONNECT PROBE TO ALE
PRESS PROBE BUTTON WHEN READY

7. Connect the probe common clip to the UUT common.
8. Probe the specified pod line as directed. You may need to refer to the UUT schematic for convenient probing locations.
9. With the probe tip touching the point being probed, push the probe ready button.

4/Maintenance

Software calibration should be performed when the system is first set up and at regular intervals (at least monthly) thereafter. Calibration is also necessary whenever devices attached to the system are changed or repaired.

The system can also be calibrated by restoring data generated by previous calibrations. This process, described under "Saving and Restoring Calibration Data" later in this section, should be performed after each power-up or reset and before UUT testing or troubleshooting.

Probe Offset Correction

Probe offset correction calibration calculates the offset voltage of the Probe input circuitry and stores the value in an EEPROM. This procedure is required only if the Probe I/O or Main PCAs are repaired or replaced.

A utility program is required to perform the probe offset correction calibration. This utility program is included on the 9100A Service Utility disk, which is part of the 9100A Service Kit (see Troubleshooting).

Probe Compensation

This calibration procedure matches the impedance of the Probe to that of the cable connecting the Probe to the system. Probe impedance is adjusted with COMP ADJ, a trimmer capacitor located on the side of the system.

Figure 4-8 shows oscilloscope connections used during probe compensation. To compensate the Probe, use the following steps:

1. Ensure that the oscilloscope and its Probe are properly calibrated.
2. Connect the oscilloscope probe tip to the system CAL OUT post. Then connect the oscilloscope probe common to the system GND post. Both posts are accessible through labeled holes in the side of the mainframe.
3. Press the MAIN MENU key, and use the left arrow key to move the cursor to the left-most field.
4. Press the CAL softkey.
5. Use the right arrow key to move the cursor to the next field, and press the PROBE softkey.
6. Move the cursor to the next field, and press the COMP softkey. The display should now read:

```
MAIN: CAL PROBE COMP
```

3. Press the CAL softkey.
4. Move the cursor to the next field, and press the I/O MOD softkey.
5. Move the cursor to the next field, and press the POD softkey.
6. Move the cursor to the next field, and press the desired softkey. For example, if you intend to use the 9100A/9105A in SYNC I/O MOD TO POD ADDR mode, press the ADDR softkey. In this case, the display should read:

MAIN: CAL I/O MOD TO POD ADDR
7. Press the ENTER key. This display should read:

MAIN: CAL I/O MOD TO POD ADDR
INSTALL CAL HEADER IN DESIRED I/O MODULE
PRESS BUTTON WHEN READY
8. Plug the Calibration Module into the I/O Module, and press the Calibration Module ready button. Make sure the calibration lead on the Calibration Module is unconnected when pressing the ready button.
9. After a few seconds, a pod dependent message is displayed. For example, the display may read:

COMPLETED EXT CAL PRIOR TO CAL POD
NOW CONNECT CAL LEAD TO ~S1
PRESS BUTTON WHEN READY
10. Refer to a schematic of the UUT and locate the specified signal. At a suitable point on the UUT, attach the calibration lead to this signal.
11. Press the Calibration Module ready button. After several seconds, the display should read:

MAIN: CALIBRATION COMPLETE
12. Repeat steps 6 through 11 for each SYNC mode in which the 9100A/9105A is to be operated.

SAVING AND RESTORING CALIBRATION DATA

Calibrating the 9100A/9105A at every power-up or reset is not necessary. A more convenient procedure is to restore calibration data from the user disk after the self tests have been performed and the system configured.

Each calibration generates data, which can be saved on the user disk using the SETUP MENU key. Once the system is calibrated for a given Pod, Probe, Clock Module, and I/O Module, the data is good until one or more of those devices is changed.

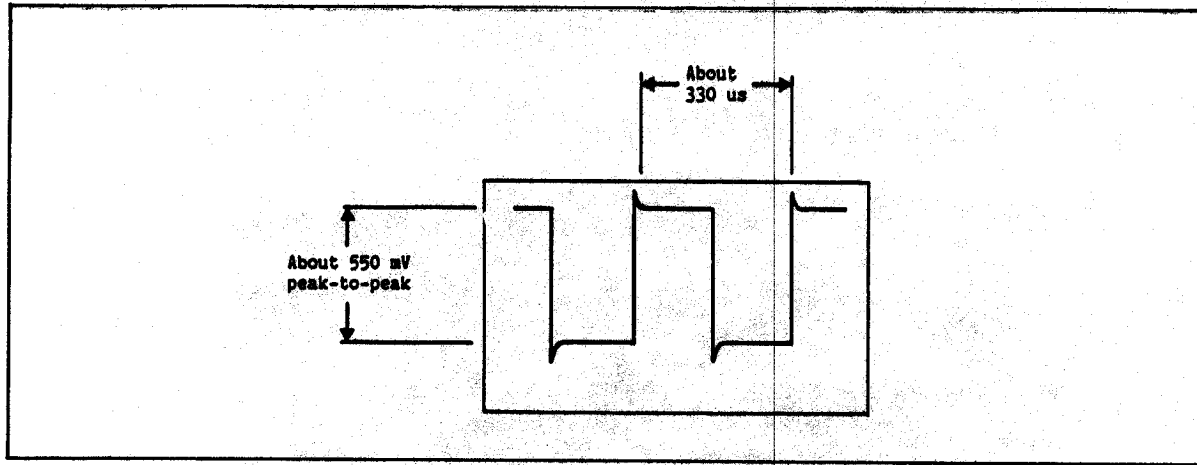

Figure 4-9. Probe Compensation Square Wave

Software Calibration

The Probe Compensation adjustment and the Probe Offset Calibration are the only hardware calibrations required for the 9100A/9105A. All other calibration is performed in software and is lost if the system is turned off, restarted, or reset. The software calibration data can be saved on disk and restored from disk to recalibrate the system. However, the restored calibration data must only be used with the system on which the calibration was performed. Any change in system hardware (Interface Pod, I/O Module(s) Clock Module, or Probe) requires system recalibration; the resulting new calibration data should be saved.

All of the software calibration procedures are intended to be performed by the system operator and do not require test equipment. Pod-related calibration procedures require the use of a known good Unit Under Test (UUT).

PROBE TO EXTERNAL (CLOCK MODULE)

This calibration automatically calibrates the Probe's internal data delay to the external clock delay. The clock signal input is through the Clock Module, which must be connected to the system. Perform the calibration as follows:

1. Press the MAIN MENU key, and use the left arrow key to move the cursor to the left-most field.
2. Press the CAL softkey.
3. Move the cursor to the next field, and press the PROBE softkey.
4. Move the cursor to the next field, and press the TO EXT softkey. The display should read:

MAIN: CAL PROBE TO EXT

Restoring Calibration Data

Use the following procedure to restore calibration data from a user disk:

1. Press the SETUP MENU key, and use the left arrow key to move the cursor to the left-most field.
2. Press the RESTORE softkey.
3. Move the cursor to the next field, and press the CALDATA softkey.
4. Move the cursor to the next field, and press one of the following softkeys:

USERDISK Use this softkey if the calibration data was saved in the USERDISK directory. The resulting display should read:

RESTORE CALDATA FROM USERDISK

UUT FILE Use this softkey if the calibration data was saved in a UUT directory.

5. If you pressed the UUT FILE softkey in step 4, type the UUT directory name. For example, type DEMO. The display should read:

RESTORE CALDATA FROM UUT FILE DEMO

6. Press ENTER to restore the previously saved calibration data.

TROUBLESHOOTING

This manual does not contain troubleshooting procedures. Component level troubleshooting is supported by the 9100A Service Kit, P/N 818948. The Service Kit uses Guided Fault Isolation (GFI) programs to assist in troubleshooting 9100A/9105A systems. The Service Kit contains GFI and utility programs, an extender board, and instructions. To use the Service Kit, another 9105A or 9100A, an I/O Module (9100A-003), and a 9000A-68000 Interface Pod are required.

REPAIR

General Repairs

STATIC AWARENESS

Improper handling of components or assemblies may cause instantaneous or delayed electrostatic discharge damage. The yellow "Static Awareness" sheet inserted near the front of this manual explains some of the hazards associated with static electricity and sensitive components.

COMPONENTS

Several of the assemblies in the 9100A/9105A are built with surface mount components. See the following Surface Mount Repair information concerning mechanical design and repair of these components.

Surface Mount Repair

SURFACE MOUNT TECHNOLOGY

Surface Mount Technology (SMT) is a new component packaging and manufacturing technique that continues the trend towards miniaturization of electronic components. Although the "chip" inside the component package is the same as used with other techniques, the package is much smaller. The leads of an SMT component are soldered to the surface of a circuit assembly, rather than being inserted and soldered into holes in the circuit assembly.

Component Packages

Most common electronic components are available in Surface Mount Technology. The SMT component packages used in the 9100A are illustrated and described in the following paragraphs.

The Small Outline Integrated Circuit (SOIC) package is rectangular with gull wing shaped leads, spaced 0.05 inches on center. The SOIC comes in a narrow body package with 8 to 16 leads, and in a wide body package with 14 to 28 leads. See Figure 4-10.

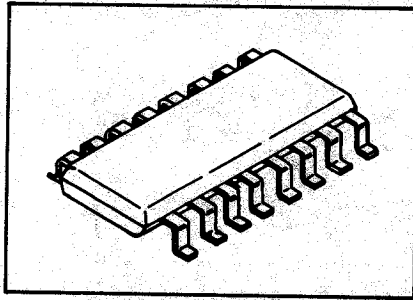

Figure 4-10. Small Outline Integrated Circuit (SOIC)

The Plastic Leaded Chip Carrier (PLCC) package is square or rectangular in shape, with 0.05 inch on-center leads located on all four sides. The leads are formed in a "J" shape, wrapping underneath the body. The PLCC is used for for large devices with 20 to 84 leads. See Figure 4-11.

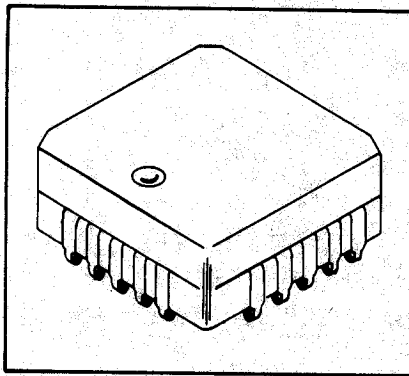

Figure 4-11. Plastic Leaded Chip Carrier (PLCC)

Not all ICs are available in surface mount packages. Therefore, some printed circuit assemblies use a mixture of DIP packages and SMT devices. A DIP packaged IC that has been modified for surface mounting (leads cut short) is called a butt-soldered dual inline package. See Figure 4-12.

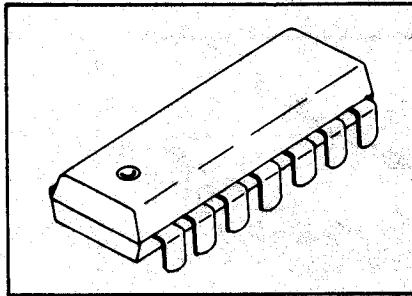

Figure 4-12. Butt-Soldered DIP

Transistors and diode pairs are packaged in several sizes of Small Outline Transistor (SOT) packages. The SOT-23 package, shown in Figure 4-13, is the most common package for small signal transistors; the leads are grouped with the collector on one side and the base and emitter leads on the opposite side.

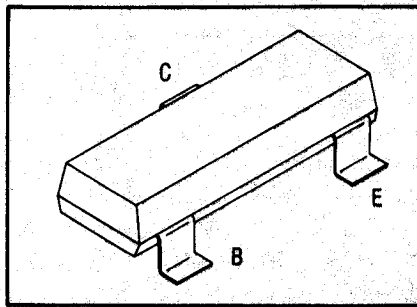

Figure 4-13. Small Outline Transistor (SOT)

Signal diodes, rectifiers, and zeners are packaged in a cylindrical Metal Electrode Face bonded (MELF) package. The stripe indicates the cathode end. See Figure 4-14.

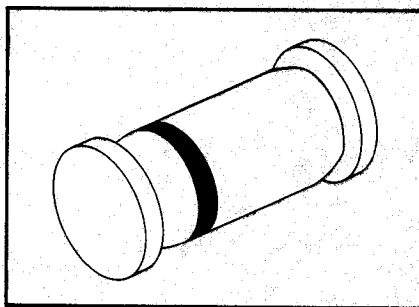

Figure 4-14. Metal Electrode Face (MELF)

Resistors and capacitors are packaged in rectangular ceramic leadless bodies, commonly called chips. See Figure 4-15.

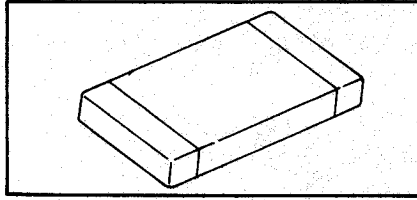

Figure 4-15. Chip Component

Printed Circuit Assembly Design

Surface Mount Technology impacts the way printed circuit assemblies are designed. Assembly layout is simplified because conductive traces do not have to be routed around protruding component leads. As a result, surface mount assemblies typically have fewer layers. The assembly layers are interconnected with plated through-holes called vias. The reduction of component lead spacing from 0.1 to 0.05 inches has shrunk traces and spacings to approximately half the previous size.

Fluke has developed a circuit pad "footprint" for surface mount components that aids both test and repair. This circuit layout uses staggered test pads and vias to make room for test probes. A probe can make contact with either a test pad or a via, avoiding the component lead and preventing an open solder connection from being temporarily closed and hidden by direct pressure on a component lead. Most signal paths do not appear on the outer surfaces of the assembly; vias connect the component pads to the signal paths on the inner layers. See Figure 4-16.

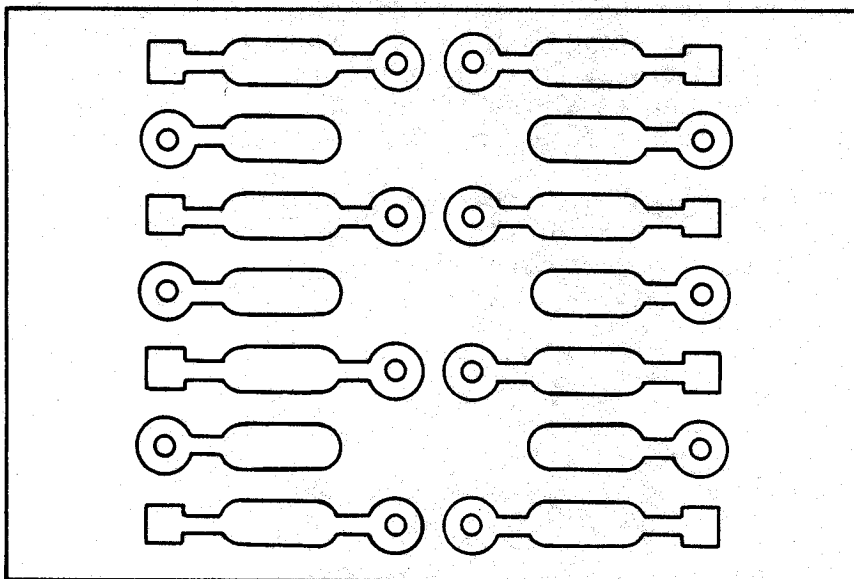

Figure 4-16. Surface Mount Footprint

4/Maintenance

SMT and Serviceability

SMT offers increased quality and reliability. When it becomes necessary, servicing can be accomplished quickly and reliably. Surface mount assemblies have a high component density, making replacement costly. However, the component level repair of these assemblies is not difficult and does not require involved training or large expense. Repair techniques for surface mount assemblies are described later in this section.

Troubleshooting SMT

Functionally, there is no difference between an IC in a DIP package and the same device in a surface mount package. Therefore, related troubleshooting techniques are very similar. Any differences in troubleshooting are related to size and mechanical construction.

When troubleshooting an SMT assembly, the circuit should be probed on the test pads or vias next to the component leads, rather than directly on the lead. This prevents disguised failures resulting from probe pressure on the lead closing a defective solder connection.

Special servicing precautions must be followed because of the reduced lead spacing on components and smaller printed circuit assembly pads and traces. Special care must be taken in the following areas:

- o Ordinary test probes can easily short two adjacent leads or pads.
- o Standard soldering irons and desoldering tools can damage the small pads of a SMT assembly.

Component Identification

Do not allow components to become mixed. Due to their size, chip components are often not marked. It is even difficult to distinguish a resistor from a capacitor. Use a clean work area, and keep the chip components in labeled packages. With limited space available, the assemblies seldom provide silk-screened reference designators for chip components. Technicians must rely on the circuit assembly layout drawings and parts lists for chip component locations and values.

Surface mount ICs are marked with the device number, but their leads are indexed differently from those on DIP packages. On the PLCC package, pin number one is indicated by a dimple in the plastic called an index dot. See Figure 4-17.

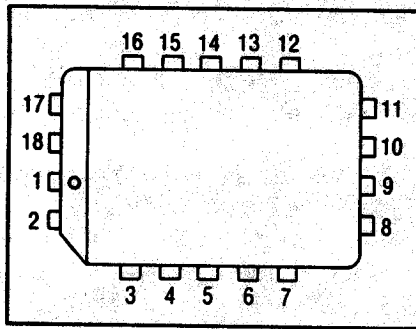

Figure 4-17. PLCC Lead Index

Pin number one on the SOIC package is located on the far left of the beveled side. SOIC packages do not have a notch or dimple to indicate pin one. See Figure 4-18.

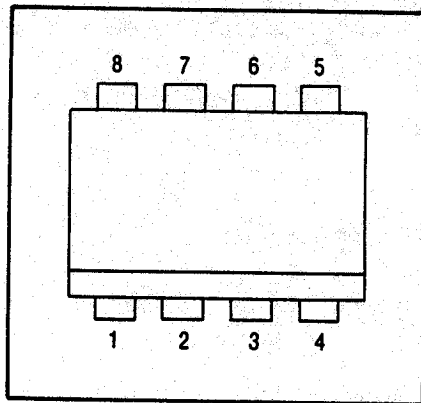

Figure 4-18. SOIC Lead Index

REPAIR TECHNIQUES

Although surface mount assemblies are repaired with somewhat different tools and techniques than through-hole printed circuit assemblies, the techniques and tools required are not complicated. In fact, a surface-mounted IC can be removed and replaced much faster and easier than a DIP package. Surface mount repair is simpler in that no through-hole solder must be removed.

Solder flux is used chemically to clean both the component lead and the solder. The flux removes oxides from the metals and acts as a wetting agent. With SMT, only enough solder to make a positive metallic contact is necessary; too much solder can cause bridging. Also, solder provides the only mechanical fastening for SMT; too little solder can cause weak or open solder joints.

Rework of SMT assemblies is often performed under a five-inch illuminated magnifier lamp. The lamp is used when applying the solder, positioning the component, or inspecting the finished rework.

Hot air from a heat gun is used to reflow the solder. This technique, called convection reflow, requires careful application of controlled heat. Excess heat can damage components, other solder joints, and the board. To prevent components from being overheated, temperature sensitive paint is applied to the top of the component. The paint liquefies when the proper reflow temperature of the solder has been reached. An adapter or reducing nozzle is used on the heat gun to direct heat to a specific component without disturbing adjacent components.

CAUTION

The fine, closely-spaced traces and pads that are used in SMT are fragile and easily separated from the surface mount assembly. Care must be taken when removing a component. Make sure the solder has reflowed on all the pins before removing the component. Wait until the temperature sensitive paint liquefies and changes color, then remove the component. Attempting component removal before the solder has melted can result in separation of the pad and possibly the trace.

Removal of Integrated Circuits

Use the following procedure to remove surface mounted ICs:

1. Apply a drop of temperature sensitive paint to the top of the IC. The paint dries quickly.
2. Use the heat gun with adapter or nozzle to heat the component, taking care to aim the hot air only at the leads. The paint turns to a clear liquid when the component reaches 400 °F, the reflow temperature of the solder.
3. When the solder has reflowed, carefully lift the component off the board. Attempting to move the component before the solder has melted can damage the circuit assembly.

Removal of Chip Components and Transistors

Chip components and transistors can be removed as outlined above. Since it is easier to see the solder reflow on two- and three- terminal components, paint application is not necessary. However, in some cases it is easier to use a low wattage soldering iron with slot tip adapters instead of the heat gun. For component removal with the iron, apply the slotted tip so that the tinned surface touches the solder fillet between the component lead and the assembly pads. Do not press on the assembly while heating. Contact the assembly gently and let the heat of the tip do the work. As soon as the solder melts completely, remove the component from the assembly with a slight twisting action of the iron tip. The component adheres to the wetted surface of the tip through capillary action.

4/Maintenance

Installing Integrated Circuits

Use the following procedure to install surface mounted ICs:

1. Once the defective component has been removed, prepare the assembly for the replacement component.
 - a. If sufficient solder remains on the pads, brush them with liquid flux, and continue to the next step.
 - b. If sufficient solder does not remain on the pads, add solder to the pads with small diameter solder, using a low wattage or temperature-controlled soldering iron. If the amount of solder on the pads is not even, gently brush a wide tip soldering iron across the pads. This technique removes solder from pads that have an excess and adds solder to pads that have less. To prevent damage to the board, perform all work quickly using a light iron pressure and no rubbing.
2. Apply a drop of temperature sensitive paint to the top of the IC.
3. Place and align the component on the pads. Perfect alignment is not necessary. Once the leads are partially placed on the correct pads, the molten solder pulls then onto the center of the pad.
4. Use the gun to heat the component, taking care to aim the hot air only at the leads. The paint becomes liquid when the component reaches the reflow temperature of the solder.
5. Once the component has reached the reflow temperature, remove the heat. If the component is not aligned perfectly on the pads, tap the board very gently while the solder is still molten. This procedure allows the surface tension of the solder to pull the component leads on to the pad centers. Allow the assembly to cool. Clean and inspect the solder joints as outlined in the following paragraphs.

Cleaning

The flux residue must be washed off immediately after repair. The longer the flux remains, the harder it is to clean. Flux residue also makes inspection and future repairs very difficult and can cause shorts. An aerosol freon spray flux remover/cleaner is sufficient to clean the reworked area.

Inspection of Rework

SMT miniaturization allows for closely spaced solder joints that must be carefully inspected for defects. A lighted magnifying glass is required to inspect the working area adequately.

A good solder joint exhibits the following qualities:

- o Absence of excess solder. The shape of the lead is clearly outlined in the joint.
- o The joint is completely covered with solder.
- o Filled areas have a concave contour.
- o Edges are feathered.

Inspect each component for the following characteristics:

- o On a chip component the solder should wick three quarters across the face and two thirds up the side of the contact surface. See Figure 4-19.

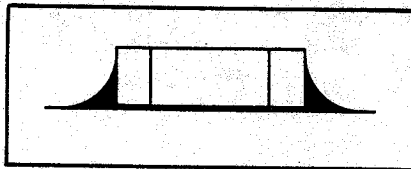

Figure 4-19. Chip Soldering

- o On a PLCC device the solder should fill both outside rounded areas of the "J" lead with a smooth, concave contour. See Figure 4-20.

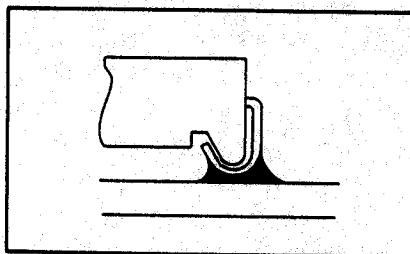

Figure 4-20. PLCC Soldering

- o On an SOIC or flatpack device the solder joint should extend the full length of the portion of the lead that makes contact with the pad. The lead outline should be clearly visible under the solder. See Figure 4-21.

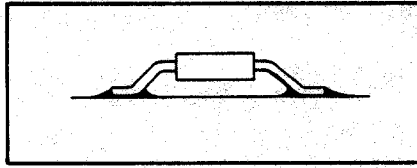

Figure 4-21. SOIC Soldering

Inspect each solder joint for the following defects:

- o Solder balls. The solder should reflow into a single mass on the pad. However, some smaller solder spheres may not combine with the main sphere of solder. Remove solder balls by cleaning the solder connections with a small brush.
- o Solder bridges. Solder may bridge two adjacent pads if applied in excess. A solder bridge may be removed with a soldering iron.
- o Missing solder. If the solder joints are weak or incomplete, the component must be removed and resoldered correctly.
- o Cold joints. Cold solder joints have a frosted, gritty appearance. They are caused by insufficient heat or by moving the component before the solder has cooled. A component with cold solder joints must be removed and resoldered correctly.
- o Lifted pads. Pads that separate from the board cannot be repaired, and the board must be scrapped. The best way to prevent board damage is to avoid excessive heat and allow the solder to reflow completely before removing components.
- o Flux residues. Any flux residues remaining on the board after cleaning must be removed with further cleaning.

TOOLS AND SUPPLIES

The tools and supplies mentioned in Table 4-6 have been carefully selected for efficient and reliable rework. Substitutions of the heat gun must be made with care. The correct solder and proper application of heat are critical for reliable repair of SMT assemblies.

Table 4-6. SMT Rework Tools and Supplies

DESCRIPTION	MODEL NUMBER
Hot air rework station, solder nozzle adapters	Leister Labor "S", Model 7A #31D6, for 14- and 16-pin SOICs #31D5, for 28-, 44-, and 68-pin PLCCs
- or -	
Heat gun with reducing baffle 750°F nozzle temperature	Ungar heat gun, Model 6966C Reducing baffle, Model 6958
Soldering iron, 15W	Soldermaster Model SMD10
Soldering iron tips for chip components and transistors	Soldermaster number S102 and S203
Solder, Multicore	Xersin 2055 Fluke P/N 715565
Temperature indicating paint 400°F/204°C	Omega Omegalaq, 2 oz bottle
T.M.C. Cleaner (rosin flux remover)	Sprayon Number 2009
Flux	Xersin 2005 Fluke P/N 715573

Repair Information

GENERAL

Many of the assemblies in the 9100A/9105A use Surface Mount Technology (SMT). The repair techniques for these printed circuit assemblies (PCAs) are different than those used for the older-style printed circuit boards that use throughhole mounted components. For more information on SMT, see the Surface Mount Repair information in this manual.

Some of the assemblies in the 9100A/9105A are Original Equipment Manufacturer (OEM) modules; each of these modules is treated as a single part. This Service Manual does not contain component level parts lists for these modules, since they are not manufactured or supported to the component level by Fluke.

MAIN PCA

The Main PCA almost exclusively uses surface mount technology. Many of the other assemblies in the 9100A/9105A mainframe connect directly to the Main PCA. These assemblies include the Power Supply, Floppy Disk Drive(s), RAM Modules, Display PCA, Probe I/O PCA, Multi-Function Interface PCA, and Video Controller PCA. The fan and serial Ports 1 and 2 plug into the Main PCA. Also, an Interface Pod and the Programmer's Keyboard plug into external connectors on the Main PCA.

The Main PCA includes an EEPROM, U11, that contains characterizing data for the instrument and stores certain parameters. If this EEPROM is to be replaced, the replacement must be ordered as a programmed part. Certain characteristics must be programmed into it after the replacement EEPROM is installed; this can be done by a Fluke Technical Center, or with a utility program that is included with the 9100A Service Kit. Also, certain other hardware changes require that the EEPROM be reprogrammed.

CAUTION

When reinstalling the Main PCA (or rear panel) take care to connect the cables from the RS-232 ports to the correct connectors on the pca. Improper connections can cause a short to earth ground. Proper connections are: RS-232 Port 1 to J3 on the Main PCA and RS-232 Port 2 to J2 on the Main PCA.

DISPLAY AND KEYPAD

The Display PCA uses surface mount technology. The Keypad PCA connects to the Display PCA.

Display and Keypad PCAs have several built in self tests and diagnostics; these are described under "Display Self Test" earlier in this section. The self tests allow checking and some troubleshooting of the display and operator keypad functions.

The Display PCA contains a vacuum fluorescent display tube. This display tube has a glass envelope and is susceptible to breakage. Caution should be taken to prevent sharp blows or direct pressure to the glass envelope or to leads of the vacuum fluorescent tube.

The display tube is driven with high voltage (approximately 70 volt pulses at the grids and anodes). Attempting to measure the outputs of the driving circuitry or the inputs to the display tube with a logic probe or other low voltage measuring device can cause equipment damage.

The Keypad PCA's only active components are the key switches and a single light-emitting diode.

PROBE I/O

The Probe I/O PCA uses surface mount technology extensively. It includes several custom LSI components. The I/O Connector PCA and Trigger Output connector plug into this assembly. The Clock Module, Single-Point Probe, and the External Switch plug into external connectors. The Probe fuse holder is also mounted on the Probe I/O PCA.

The Probe I/O PCA contains the logic probe signal input circuitry. Changes to portions of this circuitry cause calibration changes. Probe compensation should be performed after any changes in the probe input circuit, including replacing or changing the Single-Point Probe. Any changes in the probe threshold or DAC (digital to analog) circuits require reprogramming the probe offset level in the EEPROM (U11 on the Main PCA); this can be done by a Fluke Technical Center, or with a utility program that is included with the 9100A Service Kit.

I/O CONNECTOR

There is no special repair information for the I/O Connector PCA.

SINGLE-POINT PROBE

The Single-Point Probe primarily uses surface mount technology. Repair or replacement of the probe, or use of another probe, requires that the probe compensation adjustment be performed.

CLOCK MODULE

The Clock Module is partially based on surface mount technology.

When reinstalling the Clock Module case or flying lead wires, take care to install them correctly. The case should be installed with the signal name "COMMON" next to the black lead wire; the flying lead wires should be installed with the black lead wire on the same side of the assembly as the fuse holder. Remember to install the plug in the case hole (opposite the fuse holder).

4/Maintenance

RAM MODULES

The 9100A/9105A use several different RAM modules.

- o The 512K RAM Module uses surface mount technology exclusively and is supported to the component level. This assembly can be identified by the double row of RAM chips on the module.
- o The 256K RAM Module is an OEM part and is replaced as a single part. This assembly uses a single row of RAM chips on the module.

The RAM modules plug into the Main PCA. The RAM Address switches on DIP switch U83 must be set correctly for the RAM module combination installed. See Table 4-7 for the correct settings. If a new RAM configuration is installed, the EEPROM must be reinitialized by a Fluke Service Center or by using a utility program included with the Service Kit.

Table 4-7. RAM Configuration (U83)

MODULE TYPE		TOTAL	ADDRESS	SWITCH
U13/U14	U15/U16	BYTES	RANGE	SEGMENTS
				1234 5678
512K	256K	1.5M	C00000-D7FFFF	1001 1011 (9B)
512K	512K	2M	C00000-DFFFFFF	1001 1001 (99)
1M		2M	C00000-DFFFFFF	0010 0001 (21)
1M	1M	4M	C00000-FFFFFFF	0011 0001 (31)

1 = ON (closed)
0 = OFF (open)

POWER SUPPLY

The Power Supply is an OEM assembly and is replaced as a single part. The Power Supply is a switching supply and should not be operated without the correct load.

The power supply has one user adjustment. The +5 volt supply can be adjusted for the correct voltage. Adjust R44, if necessary, for a +5V supply voltage of +5.1V +/- 0.01V with a normal load. No other power supply adjustments should be attempted.

The other power supply voltages should measure, with a normal load, as follows:

- o The +12V supply should be +12V +/- 0.5V.
- o The +12VN supply should be +12V +/- 1.0V.
- o The -5V supply should be -5V +/- 0.25V.

FLOPPY DISK DRIVE

The Floppy Disk Drive is an OEM assembly and is replaced as a single part. When installing a new floppy disk drive, check that the jumper settings on the drive match those in Table 4-8. Also, when a floppy disk drive, hard disk drive, or hard disk controller is replaced with a different type, the EEPROM must be reinitialized. This procedure can be carried out by a Fluke Service Center or by using a utility program included with the Service Kit.

Table 4-8. Floppy Disk Jumper Settings

Drive Position	Jumpers					
	A	S	S	S	S	S
	H	H	3	2	1	0
Drive 1	■	○	■	○	○	○
Drive 2 (9105A only)	■	○	○	○	■	○

HARD DISK AND CONTROLLER

The Hard Disk Drive and the Hard Disk Controller are OEM modules, and each is replaced as a single part. The Hard Disk Controller is mounted to the bottom of the disk drive bracket.

The hard disk is mechanically fragile. It should be allowed to "park" itself before the instrument is turned off or moved. The disk drive parks ten seconds after the last disk access; the DISK ACCESS light on the display flashes once, and the disk drive beeps when it parks. Shaking or jarring of the disk drive while it is operating or before it has parked can damage the drive and cause loss of data on the disk.

Because the Hard Disk can easily be damaged by incorrect operation, it is good practice to disconnect the hard disk when troubleshooting a non-functional 9100A. To do this, unplug the power connector from the drive before turning on the 9100A power.

A replacement hard disk must be formatted before the operating software and user data can be loaded. The disk can be formatted with the Service utility program in the 9100A Service Kit, or the hard disk can be ordered pre-formatted.

4/Maintenance

The operating software can be loaded on a formatted hard disk even if the 9100A is not able to boot up from the hard disk. Use the following procedure:

1. Put the System Disk 1 floppy disk in the floppy disk drive.
2. Hold down the "SOFT KEYS", "F2", and "F4", and turn on the 9100A power (or press the Restart button on the right side panel if the power is already on).
3. When the display message indicates that it is booting from the floppy disk, release the three keys.
4. Change to System Disk 2 when instructed by the display.
5. When the 9100A displays the READY message, the software can be loaded on the hard disk by using the COPY function in the Main Menu to copy the System and User disks (and Programmer's software, if applicable) from the floppy disks to the hard disk. See Section 3 of the Technical User's manual for more information on copying disks.

MULTI-FUNCTION INTERFACE

The Multi-Function Interface PCA is standard only in the 9100A. This assembly plugs into J6 on the Main PCA (the 96-pin connector on the right). The Hard Disk Controller is connected through a cable to a connector on the Multi-Function Interface; the assembly also contains the Real-Time Clock circuit. The Multi-Function Interface PCA may have several empty component spaces on the board that have been reserved for special features.

The 9105A Real-Time Clock option uses a version of the Multi-Function Interface PCA with only clock circuitry installed.

VIDEO CONTROLLER

The Video Controller PCA uses mainly surface mount technology. The Monochrome Video Interface and the Color Video Interface use the same assembly, with jumpers to select the mode. The Video Controller plugs into J5 on the Main PCA (the 64 pin connector between J4 and J6); it has an external connector that passes through the rear panel for connection to a monitor.

For the Monochrome video interface, jumper block Z1 is installed on the Video Controller PCA; jumper block Z2 is installed for the Color video interface.

MONOCHROME MONITOR

The Monochrome Monitor contains two OEM modules. The power supply is an OEM module that is replaced as a single part. The crt and Video Display Electronics PCA is an OEM set; both the crt and Video Display PCA are replaced at the same time.

I/O MODULE

The I/O Module consists of two assemblies. The I/O Main PCA uses surface mount technology, with components mounted on both sides of the board. The I/O Module Top PCA has interface connectors and a few other components.

Repair of the I/O Main PCA, which has SMT components mounted on both sides, is performed in the same way as with other SMT assemblies, except that extra care needs to be taken not to overheat the board. Too much heat applied to one side could cause nearby components on the other side to pull away from the pads or fall off the board.

Replacing the external mating connectors on the I/O Module Top PCA must be done carefully. The connectors are a high-reliability type, designed for a large number of insertion/removal cycles. Alignment of the connectors is critical to allow proper mating with the external interface modules. When replacing the connectors, align them in the same way as the mating connectors on the Clip or Flying Lead modules, below, using a full width interface module as an alignment fixture.

CLIP OR FLYING LEAD MODULES

The Clip and Flying Lead Modules interface the I/O modules to a Unit Under Test (UUT) using IC clips or flying leads. They are either half width modules, for up to 24 pins, or full width modules, for up to 40 pins. The Calibration Module (used for software calibration of the I/O Module) is similar to the full width modules.

The Clip and Flying Lead modules use internal configuration switches that are read by the I/O Module to determine the type of module attached. The half-width modules use a four-bit switch, and the full-width modules use an eight-bit switch. See Table 4-9 for a list of switch settings. When servicing a clip or flying lead module, be sure that the configuration switches are set correctly.

Table 4-9. Clip and Flying Lead Module Configuration Switch Settings

4-BIT SWITCH 4321	MODULE
0000	14-Pin Clip
0001	16-Pin Clip
0010	18-Pin Clip
0011	20-Pin Clip
0100	24-Pin Clip
1101	20-Pin Flying Lead Set

0 = on (closed)
1 = off (open)

8-BIT SWITCH 8765 4321	MODULE
1110 0000	28-Pin Clip
1110 0001	40-Pin Clip
1110 0010	Calibration Module (hardwired)

The connectors and connector alignment posts that mate the Clip or Flying Lead modules to the I/O Module must be aligned precisely with the mating connectors on the I/O Module. Use the following procedure when installing the connectors:

1. Make sure the solder is removed from all the holes for the connector before attempting to install it. The connector should fit loosely in the holes.
2. Place the connector in the holes in the board, and place the connector posts through the large holes in either end. Be sure that the notches on the posts line up correctly.
3. Put on the nuts or screws loosely enough that the connector can move somewhat. Use an I/O Module as an alignment fixture; gently plug the module being repaired into an I/O Module, taking care that the connectors mate correctly. With the connectors completely seated, tighten the nuts or screws, and solder several pins on the connector (and the alignment posts, if necessary) to hold it in place. The module being repaired can be unplugged to solder the remaining pins.

Section 5
List of Replaceable Parts

TABLE OF CONTENTS

ASSEMBLY NAME	DRAWING NO.	TABLE		FIGURE	
		NO.	PAGE	NO.	PAGE
Model Configurations		5-1	5-5		
9100 Series Final Assembly	9100A	5-2	5-6	5-1	5-8
A1 Main PCA	9100A-4001	5-3	5-17	5-2	5-19
A2 Display Interface PCA	9100A-4002	5-4	5-20	5-3	5-21
A4 Video Controller PCA	9100A-4004	5-5	5-22	5-4	5-23
A5 Probe Assembly	9100A-4005	5-6	5-24	5-5	5-25
A6 Clock Module PCA	9100A-4006	5-7	5-26	5-6	5-27
A7 I/O Module (Main) PCA	9100A-4007	5-8	5-28	5-7	5-29
A8 I/O Module (Top) PCA	9100A-4008	5-9	5-30	5-8	5-31
A9 Probe I/O Interface PCA	9100A-4009	5-10	5-32	5-9	5-34
A10 Multi-Function I/F PCA	9100A-4010	5-11	5-35	5-10	5-36
A11 I/O Connector PCA	9100A-4011	5-12	5-37	5-11	5-38
A12 Half-Width Clip Modules	9100A-4012	5-13	5-39	-	
A13 Full-Width Clip Modules	9100A-4013	5-14	5-40	-	
A14 Calibration Module	9100A-4014	5-15	5-41	-	
A15 Flying Lead Module	9100A-4012	5-16	5-42	-	
A16 512K RAM Module	9100A-4016	5-17	5-43	5-12	5-44
A19 Monochrome Monitor		5-18	5-45	-	
-003 Parallel I/O Module	9100A-003	5-19	5-46	5-13	5-47
-004 Programmer's Station, Mono	9100A-004	5-20	5-50	5-14	5-51
-005 Programmer's Station, Color	9100A-005	5-21	5-53	5-15	5-54
-008 Real-Time Clock PCA	9105A-4017	5-22	5-56	5-16	5-57
-009 Video, Monochrome	9100A-009	5-23	5-58	5-17	5-59
-011 Video, Color	9100A-011	5-24	5-61	5-18	5-62
-013 Programmer's Keyboard	9100A-013	5-25	5-63	-	

INTRODUCTION

Section 5 provides an illustrated parts list for the 9100A, 9105A, and related optional assemblies.

Components are listed alphanumerically by assembly. Both electrical and mechanical components are listed by reference designation. Each listed part is shown in an accompanying illustration.

The parts lists contain the following information:

- o Reference Designator
- o Description
- o Fluke Stock Number
- o Federal Supply Code for Manufacturers (MFRS SPLY CODE)
- o Manufacturer's Part Number
- o Total Quantity of Components per Assembly (TOT QTY)
- o Recommended Spare Quantity (RSQ)

The number in the RSQ column represents the number of spare parts necessary to support one to five instruments for a period of 2 years. This quantity assumes that common electronic parts are available at the maintenance site. To maintain the instrument for 1 year or more at an isolated site, it is recommended that at least one of each assembly in the instrument be stocked. In the case of optional subassemblies, plug-ins, etc., that are not always part of the instrument or are deviations from the basic instrument model, the RSQ column lists the recommended spare quantity for the items in that particular assembly.

5/List of Replaceable Parts

HOW TO OBTAIN PARTS

Components may be ordered directly from the manufacturer's part number, or from the John Fluke Manufacturing Co., Inc. or an authorized representative by using the Fluke Stock Number. In the event the part ordered has been replaced by a new or improved part, the replacement will be accompanied by an explanatory note and installation instructions if necessary.

To ensure prompt and efficient handling of your order, please include the following information:

- o Quantity
- o Fluke Stock Number
- o Description
- o Reference Designation
- o Printed circuit assembly (PCA) number and revision letter
- o Instrument Model Number and Serial Number

Parts price information is available from the John Fluke Manufacturing Co., Inc. or its representative. Prices are also found in the Fluke Replacement Parts Catalog, which is available on request.

CAUTION

An asterisk in the "S" (static) column indicates a device or component subject to damage by static discharge.

Table 5-1 identifies the parts lists applicable to your 9100 Series model. For example, for the 9100A Digital Test System, Tables 5-2, 5-3, 5-4, 5-6, 5-7, 5-10, 5-11, 5-12, and 5-17 would be used.

Table 5-1. Model Configurations

		9100A/SYS Digital Test Programming Station							
		9100A Digital Test System							
		9100A-003 Parallel I/O Module							
		9100A-004 Programmer's Station, Mono							
		9100A-005 Programmer's Station, Color (Table 5-21)							
		9100A-009 Video, Monochrome (Table 5-23)							
		9100A-011 Video, Color (Table 5-24)							
		9105A Digital Test Station							
RELATED PARTS LISTS:									
Table	Assembly/Option	↓	↓	↓	↓	↓	↓	↓	↓
5-2	Final Assembly	X						X	X
5-3	A1 Main PCA	X						X	X
5-4	A2 Display Interface PCA	X						X	X
5-5	A4 Video Controller PCA		X	X	X	X			X
5-6	A5 Probe PCA	X						X	X
5-7	A6 Clock Module PCA	X						X	X
5-8	A7 I/O Module (Main) PCA						X		X
5-9	A8 I/O Module (Top) PCA						X		X
5-10	A9 Probe I/O PCA	X						X	X
5-11	A10 Multi-Function I/F PCA							X	X
5-12	A11 I/O Connector PCA	X						X	X
5-13	A12 Half-Width Clip Module								X
5-14	A13 Full-Width Clip Module								X
5-15	A14 Calibration Module						X		X
5-16	A15 Flying Lead Module						X		X
5-17	A16 512K RAM Module*	X						X	X
5-18	A19 Monochrome Monitor			X		X			X
5-19	-003 Parallel I/O Module								X
5-20	-004 Programmer's Station, Mono								X
5-22	-008 Real-Time Clock PCA (optional)	X							
5-25	-013 Programmer's Keyboard				X	X			X

* -007 512K Memory Expansion is included in Table 5-17.

5/List of Replaceable Parts

Table 5-2. 9100 Series Final Assembly
(See Figure 5-1.)

REFERENCE DESIGNATOR	FLUKE STOCK	MFRS SPLY	MANUFACTURERS PART NUMBER	TOT QTY	R O S T	N
-A>-NUMERICS-----> S-----DESCRIPTION-----	--NO--	-CODE-	-OR GENERIC TYPE-----	QTY-	-Q-	-E-
A 1	* MAIN PCA	768754	89536 768754	1		
A 2	* DISPLAY INTERFACE PCA	768689	89536 768689	1		
A 3	KEYPAD ASSEMBLY	846357	89536 846357	1		
A 5	* PROBE ASSEMBLY	773911	89536 773911	1		
A 6	* CLOCK MODULE ASSEMBLY	768812	89536 768812	1		
A 9	* PROBE I/O INTERFACE PCA	768796	89536 768796	1		
A 10	* MULTI-FUNCTION INTERFACE PCA	767988	89536 767988	1		
A 11	* I/O CONNECTOR PCA	767996	89536 767996	1		1
A 16	* 512K RAM MODULE	822858	89536 822858	4		3
A 101	PWR SUP, 150W, +5V, (2)+12V, -5V	772988	89536 772988	1		
A 102	* DISK DRIVE, FLOPPY, 3.5"	829671	89536 829671	1		2
A 104	* DISK DRIVE, HARD, 3.5", FRMTD, 20MBYTS	834234	89536 834234	1		1
A 105	* WINCHESTER HARD DISK CONTROLLER	780940	89536 780940	1		1
CR 1	* LED, RED, PCB MNT, LUM INT=0.5MCD	369777	28480 5082-4480	1	1	
E 1	TERM, FASTON, REC, 18-22AWG, CRIMP, INSUL	655001	59730 RAD20377	1		
F 1	FUSE, 1/4 X 1-1/4, SLOW, 2A, 250V	109181	71400 MDX2	1		5
F 1	FUSE, 5X20MM, SLOW, 1A, 250V	808055	89536 808055	1		5
H 1	SPACER, HEX, ALUM, 4-40X0.500	192872	89536 192872	1		
H 2	SCREW, MACH, PHP SEMS, STL, 4-40X1/4	185918	89536 185918	2		
H 3	SCREW, MACH, PHP, STL, 4-40X1/2	558825	89536 558825	4		
H 4	SCREW, MACH, PH, P, STL, 6-32X0.250	152140	89536 152140	1		
H 5	NUT, WELD TAB, FLOATING, STEEL, 10-32	743393	89536 743393	2		
H 6	SCREW, MACH, PH, P, STL, 6-32X0.250	152140	89536 152140	5		
H 7	SCREW, MACH, PH, P, STL, 10-32X0.750	114306	89536 114306	2		
H 8	SCREW, MACH, PH, P, STL, 6-32X0.250	152140	89536 152140	14		
H 9	SCREW, MACH, PH, P, STL, 8-32X0.375	114124	89536 114124	2		
H 10	CONN ACC, D-SUB, LATCH BLOCK, SHORT, SLOT	811653	89536 811653	12		
H 11	SCREW, MACH, FIHS, STL, 4-40X3/8	129916	89536 129916	12		
H 12	CONN ACC, D-SUB, SLIDING LOCK, POST ASSY	353201	89536 353201	2		
H 13	CONN ACC, D-SUB, JACK SCREW, 4-40	448092	89536 448092	4		
H 14	SCREW, MACH, PH, P, STL, 6-32X0.250	152140	89536 152140	4		
H 15	RIVET, PUSH, UNIV, NYL, .16, .32	799957	89536 799957	4		
H 16	SCREW, MACH, PH, P, STL, 6-32X0.375	152165	89536 152165	2		
H 17	NUT, CAP EXT LW, STL, 6-32X7/64	152819	89536 152819	2		
H 18	DUST FILTER, SET	773994	89536 773994	1		
H 19	WASHER, SHLDR, NYLON, .320X.141X.065	733345	89536 733345	4		
H 20	RIVET, POP, DOME, AL, 0.125X0.440	800763	89536 800763	4		
H 21	FASTENER, STUD REC, TUBLR, 0.187 X 0.46	783134	89536 783134	2		
H 22	SCREW, MACH, PH, P, STL, 6-32X0.250	152140	89536 152140	8		
H 23	SCREW, MACH, PH, P, STL, 8-32X0.375	114124	89536 114124	4		
H 24	SCREW, MACH, SEMS, PH, P, STL, 6-32X0.375	177022	89536 177022	4		
H 25	SCREW, MACH, PHS, M3 X 12	799502	89536 799502	4		
H 26	SCREW, MACH, PH, P, STL, 6-32X0.500	152173	89536 152173	4		
H 27	SCREW, MACH, PH, P, STL, 6-32X0.250	152140	89536 152140	2		
H 28	SCREW, MACH, PH, P, STL, 6-32X0.250	152140	89536 152140	3		
H 29	SCREW, SHOULDER	775999	89536 775999	2		
H 30	CONN ACC, D-SUB, DUST CAP, 37 SCKT	615138	89536 615138	4		
H 31	CONN ACC, D-SUB, DUST CAP, 25 PIN	816371	89536 816371	2		
H 32	SCREW, MACH, PH, P, STL, 4-40X0.250	129890	73734 19022	1		
J 1	CONN, COAX, BNC (F), PANEL	152033	95712 30355-1	1		
MP 1	BOX, MAILER, CONVOLUTED FOAM INSIDE	707851	89536 707851	2		
MP 2	DISPLAY WINDOW, SHIELD	784009	89536 784009	1		
MP 3	9100A ACCESSORIES	788554	89536 788554	1	1	
MP 5	SHIELD, CLOCK MODULE	755793	89536 755793	1		
MP 6	CASE, CLOCK MODULE	755827	89536 755827	1		
MP 7	COVER	755686	89536 755686	1		
MP 8	CASE, CLOCK MODULE	755652	89536 755652	1		
MP 10	KEYPAD CASE TOP	765008	89536 765008	1		
MP 11	KEYTOP, SET	775858	89536 775858	1		
MP 12	KEYPAD, ELASTOMERIC	764910	89536 764910	1	1	
MP 13	CORD, LINE, 5-15/IEC, 3-18AWG, SVT	343723	89536 343723	1		
MP 14	TORSION SPRING	784025	89536 784025	2	1	
MP 15	KEYPAD CASE BOTTOM	765016	89536 765016	1		
MP 16	SPRING DETENT	765032	89536 765032	2		
MP 17	NAMEPLATE	787275	89536 787275	1		
MP 18	FRONT PANEL, PAINTED	764894	89536 764894	1		
MP 19	LENS	783993	89536 783993	1		4
MP 20	KEYPAD OPENING SHIELD	767889	89536 767889	1		
MP 21	HINGE/DETENT HOUSING	765024	89536 765024	2		
MP 22	MAINFRAME BASE	767848	89536 767848	1		

An * in 'S' column indicates a static-sensitive part.

5/List of Replaceable Parts

Table 5-2. 9100 Series Final Assembly (cont.)

REFERENCE DESIGNATOR	FLUKE STOCK	MFRS SPLY	MANUFACTURERS PART NUMBER	TOT QTY	N R S T
-A>-NUMERIC--> S-----DESCRIPTION-----	--NO--	-CODE-	--OR GENERIC TYPE----	QTY-	-Q -E-
MP 24	803221	89536	803221	1	
MP 25	801001	89536	801001	4	
MP 26	767855	89536	767855	1	
MP 27	460238	61935	031.1666	1	
MP 29	768010	89536	768010	1	
MP 30	768655	89536	768655	1	
MP 31	461020	89536	461020	1	
MP 32	565036	89536	565036	1	
MP 33	172080	89536	172080	1	
MP 34	226365	89536	226365	4	
MP 35	773986	89536	773986	1	
MP 36	768028	89536	768028	1	
MP 37	787846	89536	787846	1	5
MP 38	830398	89536	830398	1	6
MP 39	565036	89536	565036	1	
MP 40	381533	06383	PLT1M	1	
MP 41	802033	89536	802033	1	7
MP 42	782623	89536	782623	8	
MP 43	782631	89536	782631	8	
MP 44	806703	89536	806703	2	1
MP 45	472795	89536	472795	1	
MP 46	809103	89536	809103	1	
MP 47	819680	89536	819680	1	10
MP 48	757229	89536	757229	1	
MP 49	809038	89536	809038	1	
MP 50	809046	89536	809046	1	
MP 51	809053	89536	809053	1	
MP 52	809129	89536	809129	1	
SW 1	799551	89536	799551	1	1
SW 2	800649	89536	800649	1	1
TM 1	787960	89536	787960	1	
TM 2	809228	89536	809228	1	
TM 3	813832	89536	813832	1	
TM 4	813840	89536	813840	1	
TM 5	822866	89536	822866	1	
W 3	749903	89536	749903	1	
W 4	773267	89536	773267	1	
W 5	773424	89536	773424	1	
W 6	773432	89536	773432	2	
W 7	773846	89536	773846	1	8
W 8	773853	89536	773853	1	
W 9	773861	89536	773861	1	
W 10	773887	89536	773887	1	
W 11	783969	89536	783969	1	
W 12	787838	89536	787838	2	
W 13	787895	89536	787895	1	1
W 15	788448	89536	788448	1	1
W 16	788455	89536	788455	1	1
W 17	788471	89536	788471	1	
W 18	801944	89536	801944	1	
W 19	809178	89536	809178	1	
W 21	788430	89536	788430	1	9
XF 1	460329	89536	460329	1	

An * in 'S' column indicates a static-sensitive part.

NOTES:

- 1 - Not used on 9105A.
- 2 - For 9105A, quantity is 2.
- 3 - For 9105A S/Ns prior to 4352000, two 512K + two 256K (799833) were used.
- 4 - For 9105A, order p/n 805721.
- 5 - For 9105A, order p/n 805713, quantity 2.
- 6 - For 9105A, order p/n 787853.
- 7 - For 9105A, order p/n 788521.
- 8 - For 9105A, order p/n 788547.
- 9 - For 9105A, order p/n 805705.
- 10 - For 9105A, order p/n 802009.

A101 through A105 are Original Equipment Manufacturer (OEM) assemblies. List of replaceable parts is not available.

5/List of Replaceable Parts

FUSE CHART			3	
VOLTAGE	FUSE	CAP		CONFIGURATION
100/120V	109314	460238	115V	763649
220/240V	543504	461020	230V	763656

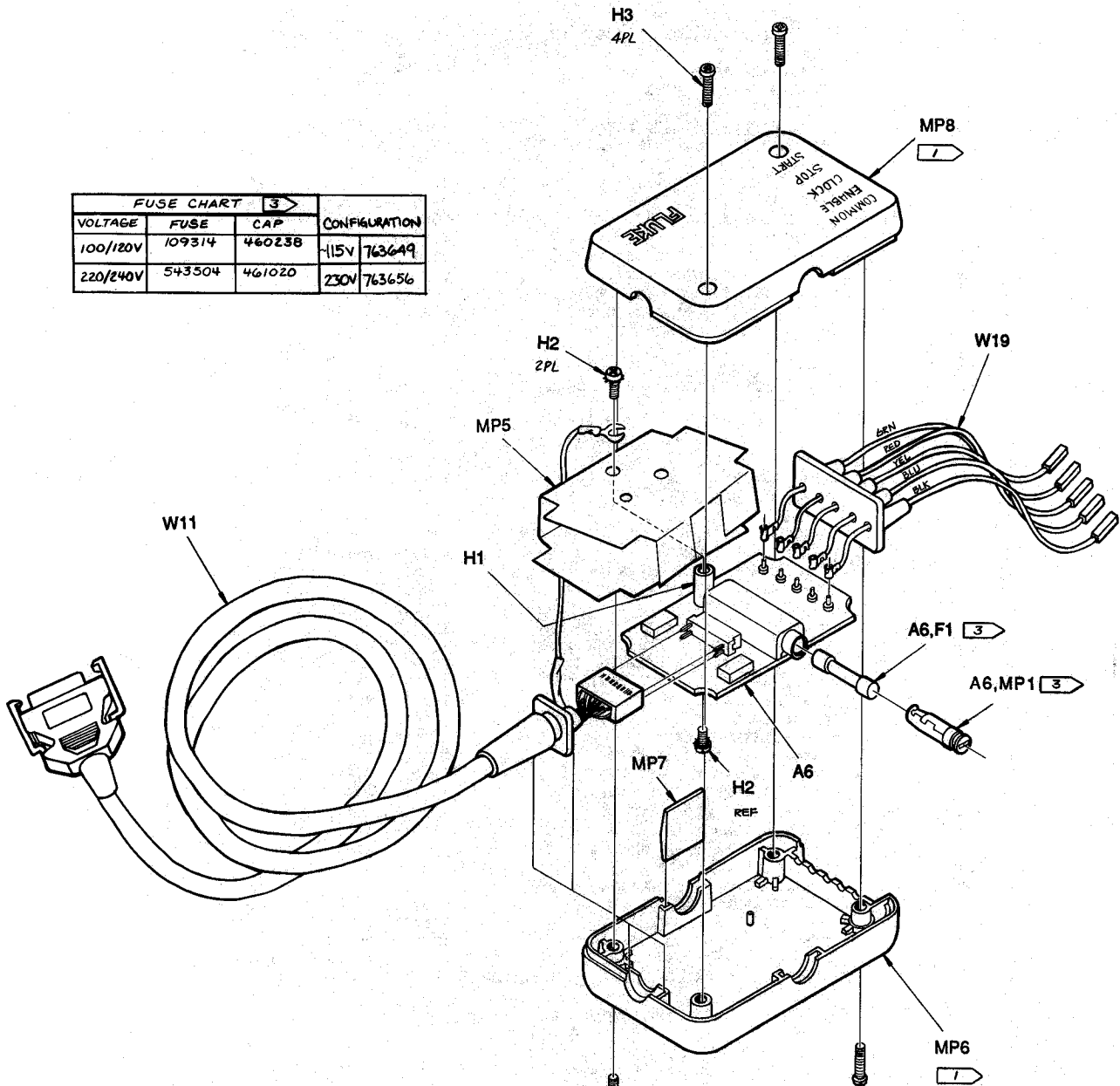

NOTES: UNLESS OTHERWISE SPECIFIED

- 1 NOTE PROPER ORIENTATION OF MP8 & MP6 CABLE NOMENCLATURE ON MP8 & MP6 MUST MATCH UP WITH COLORS OF W19 AS NOTED:
 COMMON - BLACK WIRE
 UNABLE - BLUE WIRE
 CLOCK - YELLOW WIRE
 STOP - RED WIRE
 START - GREEN WIRE

2. **WARNING:** ⚡ INDICATES USAGE OF MOS DEVICE(S) WHICH MAY BE DAMAGED BY STATIC DISCHARGE. USE SPECIAL HANDLING PER S.O.P. 19.1

3 FUSE & FUSE CAP VARY FOR DIFFERENT VOLTAGE CONFIGURATIONS: SEE FUSE CHART FOR FUSE & CAP PART NO.'S.



CAUTION
SUBJECT TO DAMAGE BY
STATIC ELECTRICITY

9100A T&B
(1 of 9)

Figure 5-1. 9100 Series Final Assembly

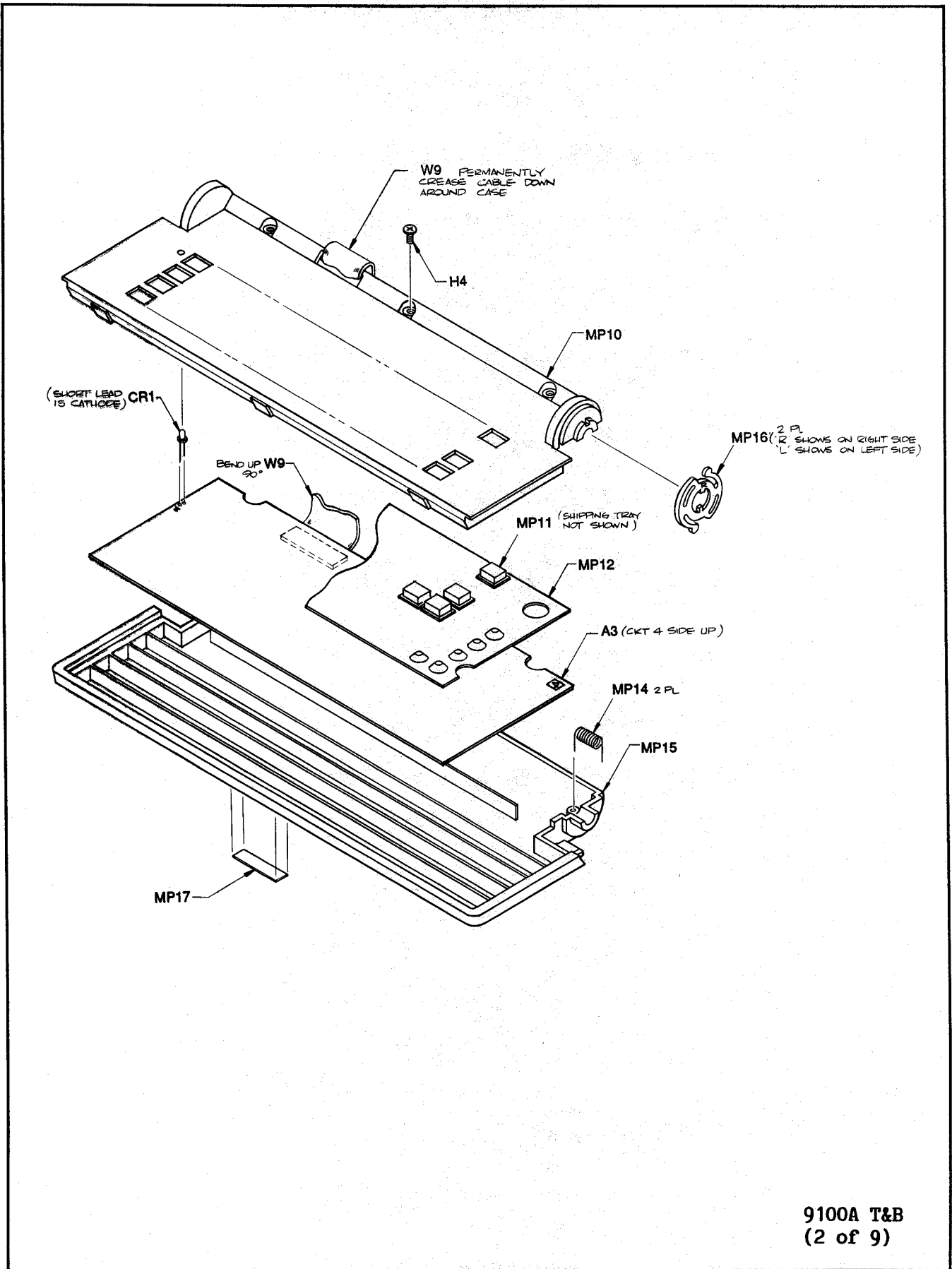

Figure 5-1. 9100 Series Final Assembly (cont.)

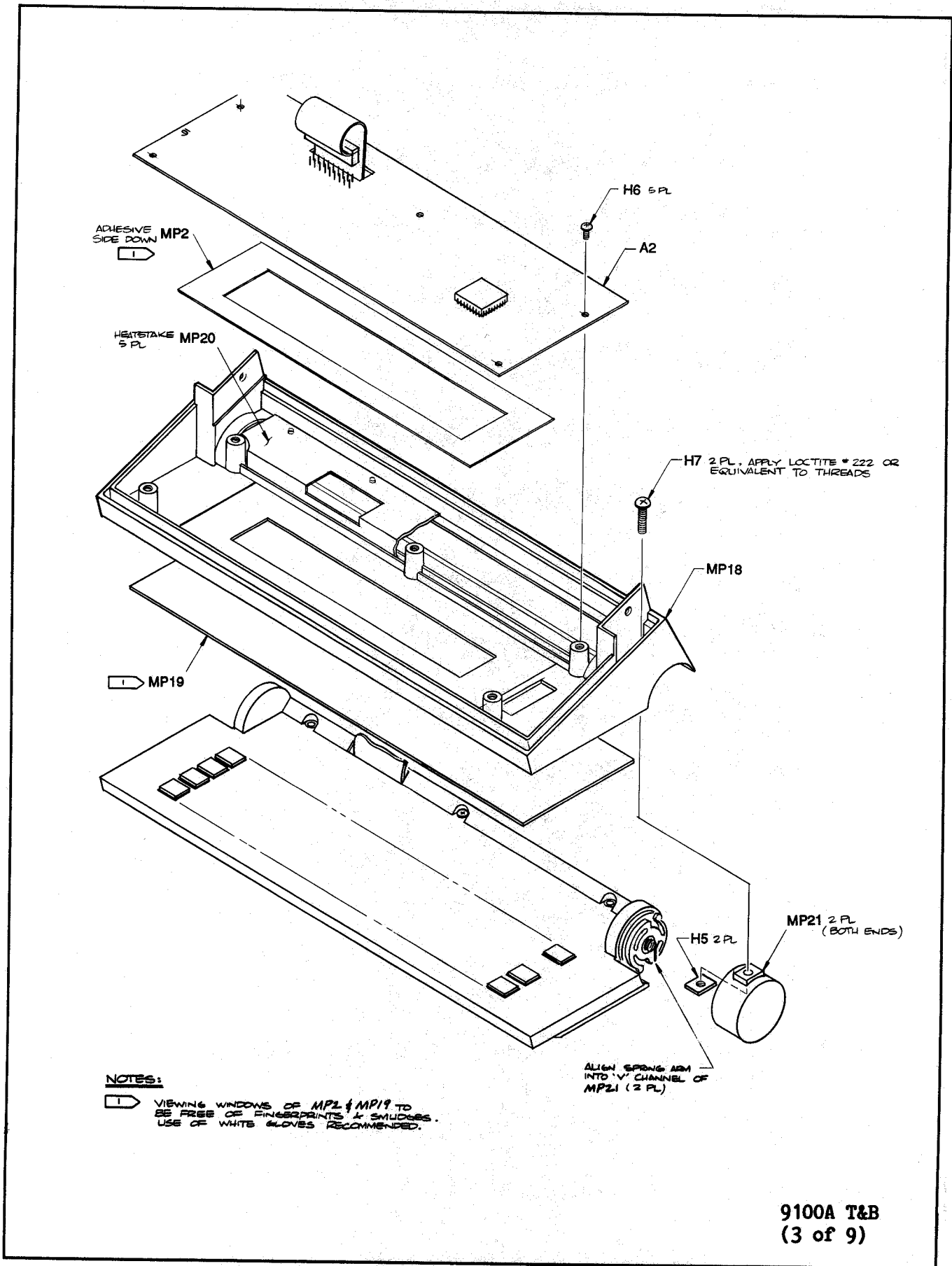
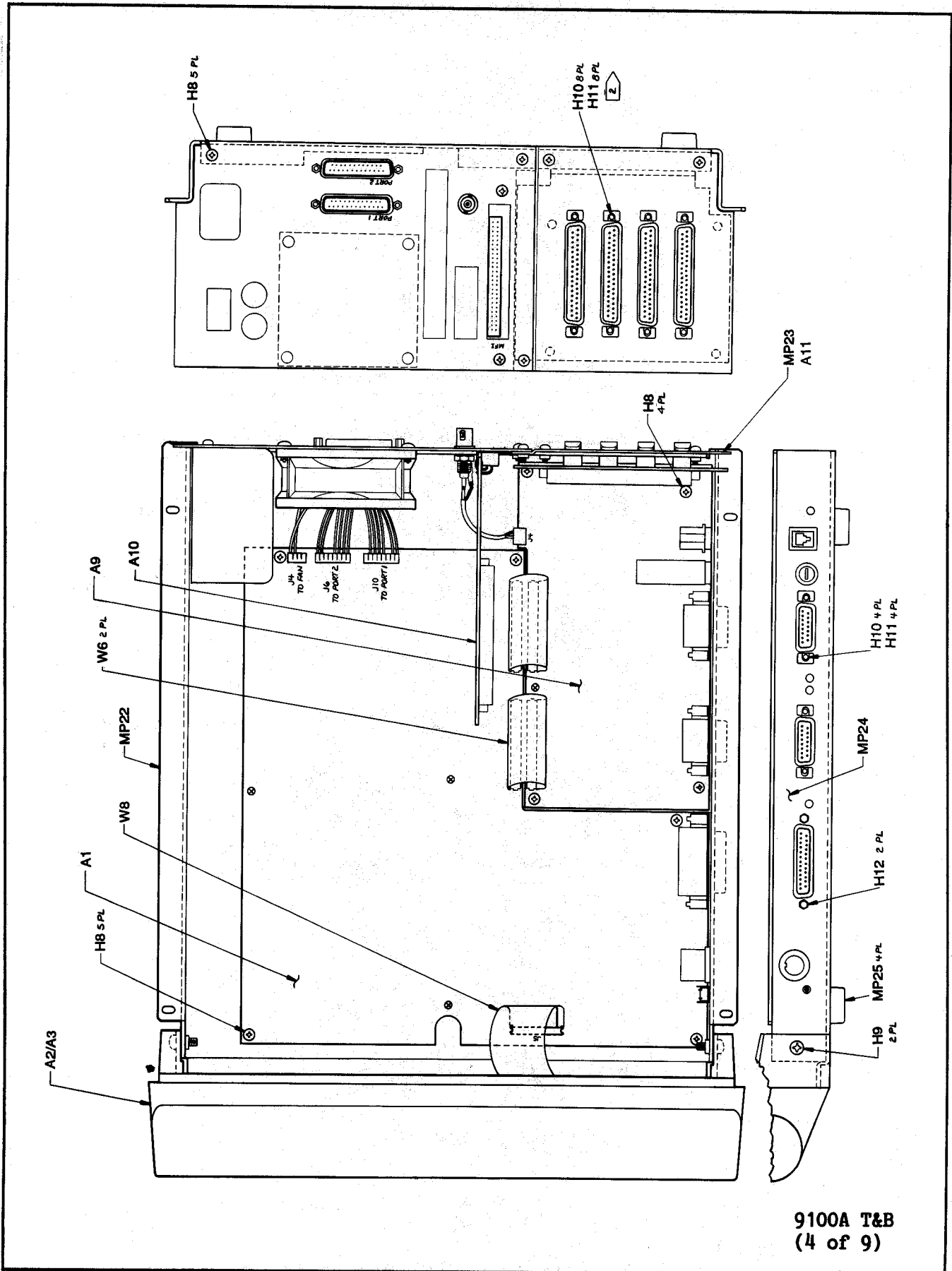

Figure 5-1. 9100 Series Final Assembly (cont.)



9100A T&B
(4 of 9)

Figure 5-1. 9100 Series Final Assembly (cont.)

5/List of Replaceable Parts

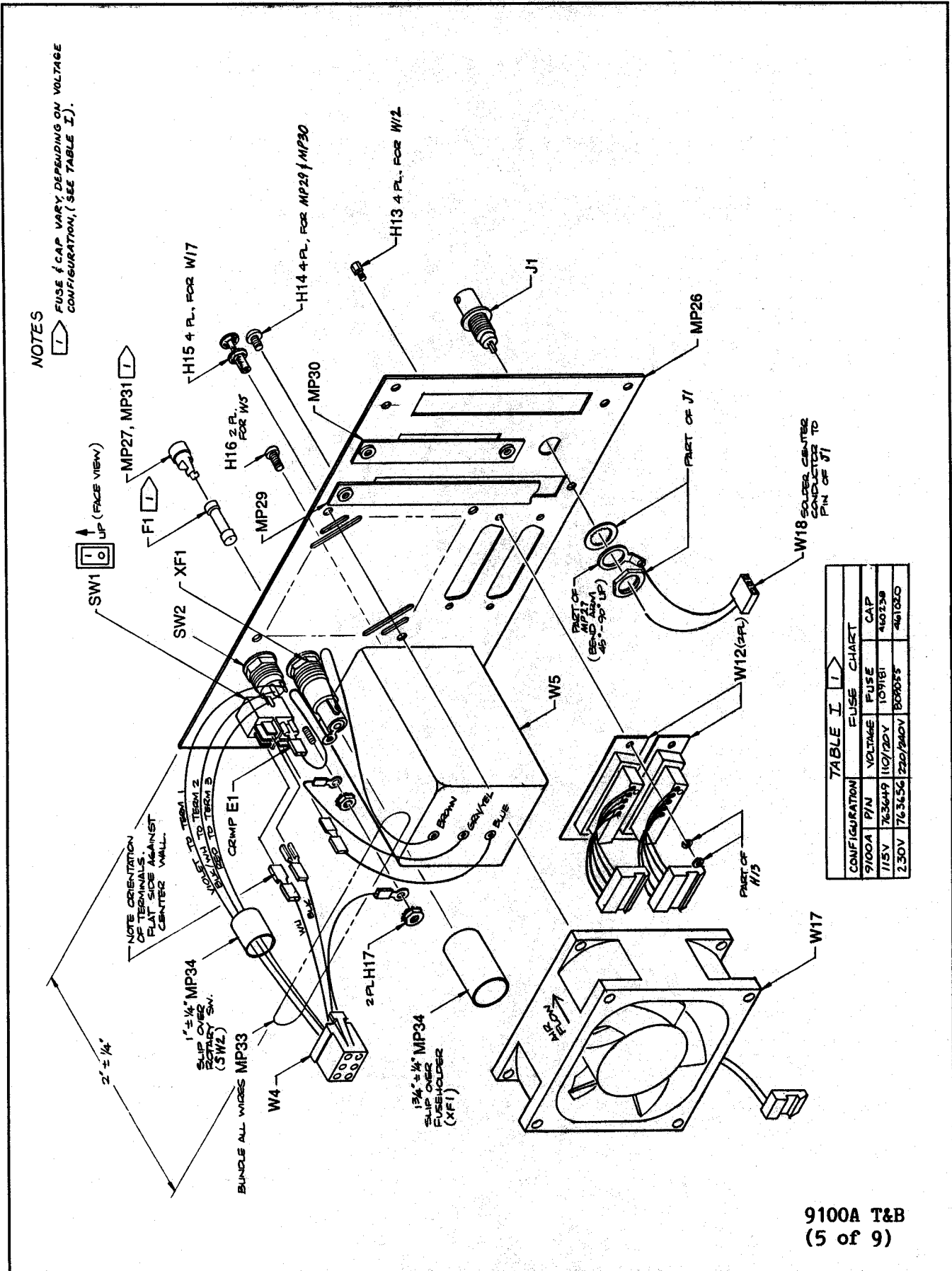
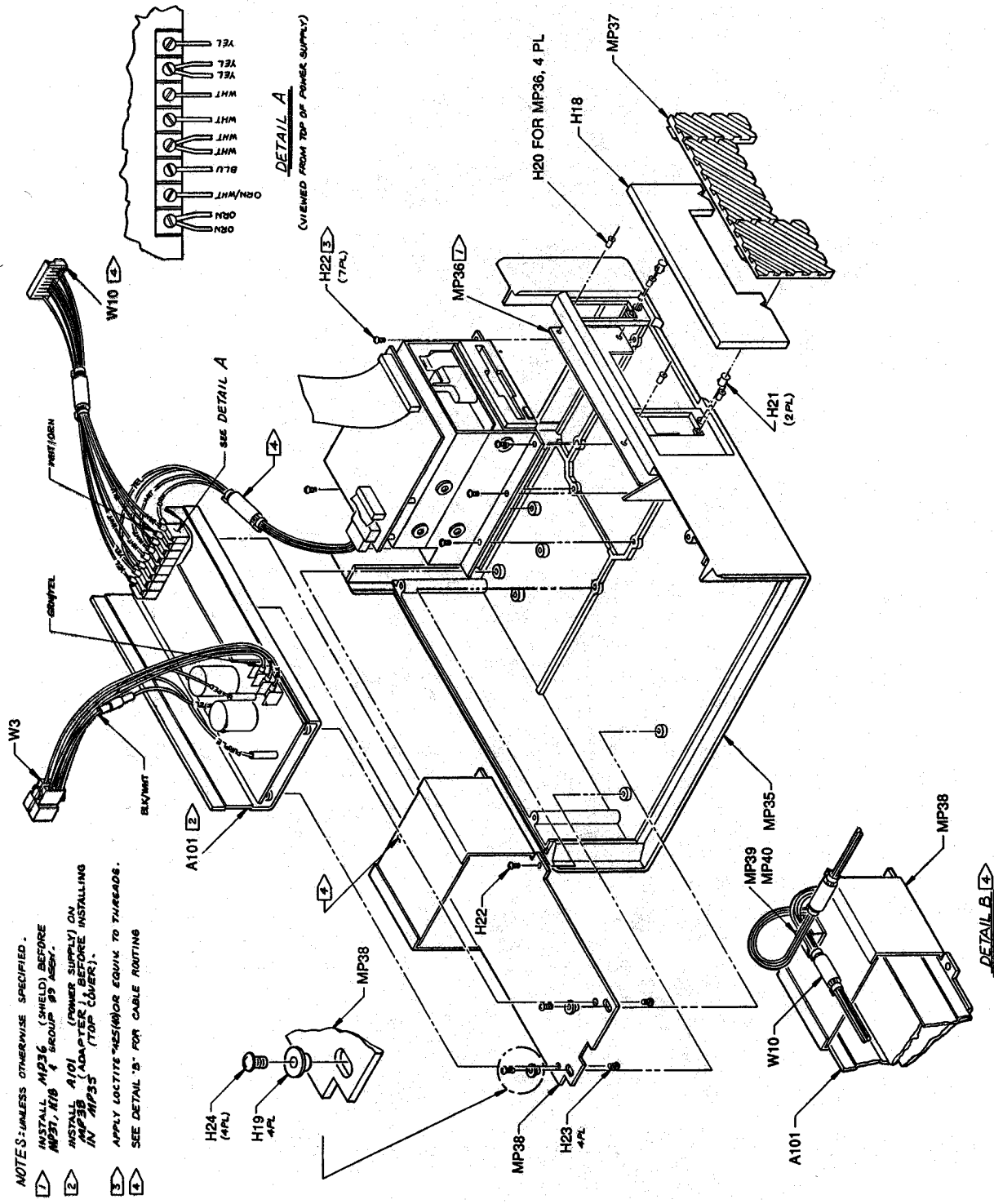

Figure 5-1. 9100 Series Final Assembly (cont.)



- NOTES: UNLESS OTHERWISE SPECIFIED.
- 1 INSTALL MP36 (SHIELD) BEFORE MP37, H18 & GROUP 33 ASSEMBLY.
 - 2 INSTALL A101 (POWER SUPPLY) ON MP35 (ADAPTOR) BEFORE INSTALLING IN MP35 (TOP COVER).
 - 3 APPLY LOCTITE MESH/ROTOR EQUIV TO THREADS.
 - 4 SEE DETAIL 'B' FOR CABLE ROUTING.

9100A T&B
(6 of 9)

Figure 5-1. 9100 Series Final Assembly (cont.)

5/List of Replaceable Parts

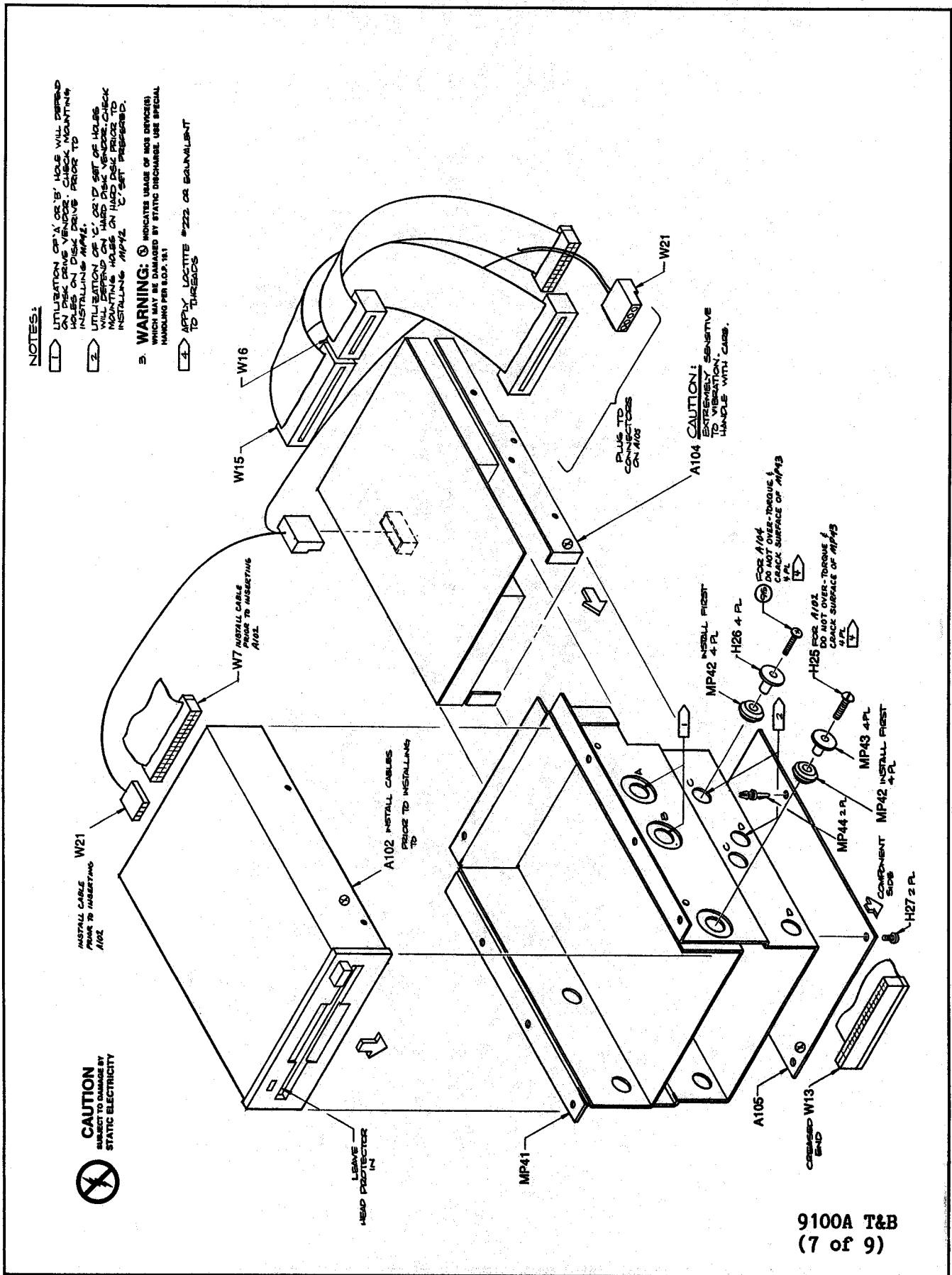
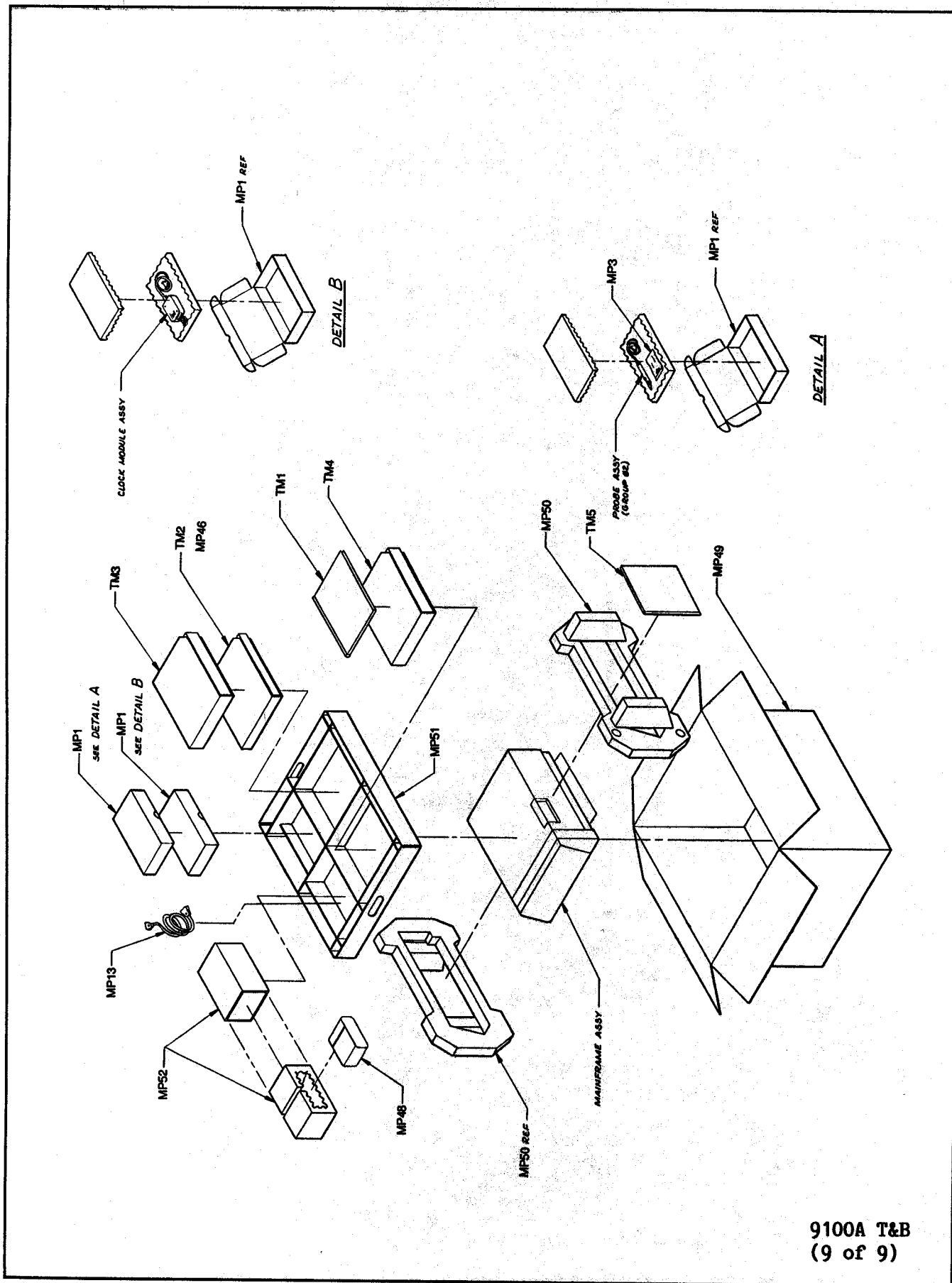

Figure 5-1. 9100 Series Final Assembly (cont.)



9100A T&B
(9 of 9)

Figure 5-1. 9100 Series Final Assembly (cont.)

5/List of Replaceable Parts

Table 5-3. AI Main PCA
(See Figure 5-2.)

REFERENCE DESIGNATOR	FLUKE STOCK	MFRS SPLY CODE	MANUFACTURERS PART NUMBER	TOT QTY	R O S T	N O T E
A> NUMERICS	NO	CODE	OR GENERIC TYPE	QTY	Q	E
C 1- 4, 6,	CAP, TA, 10UF, +-20%, 25V	772491	89536 772491	10		
C 23, 100-103		772491				
C 5	CAP, TA, 3.3UF, +-20%, 25V	780486	89536 780486	1	1	
C 10, 11, 18,	CAP, CER, 0.01UF, +-10%, 50V, X7R, 1206	747261	89536 747261	121		
C 19, 24, 110-		747261				
C 113, 120, 121,		747261				
C 130, 131, 200-		747261				
C 208, 300-310,		747261				
C 320, 321, 340-		747261				
C 343, 360, 361		747261				
C 12	CAP, CER, 1000PF, +-10%, 50V, COG, 1206	747378	89536 747378	1		
C 13	CAP, CER, 0.1UF, +-10%, 25V, X7R, 1206	747287	89536 747287	1		
C 14	CAP, CER, 10PF, +-10%, 50V, COG, 1206	747311	89536 747311	1		
C 16, 17, 20,	CAP, CER, 47PF, +-10%, 50V, COG, 1206	747352	89536 747352	4		
C 21		747352				
C 380	CAP, CER, 0.01UF, +-20%, 100V, X7R, 1206	742981	89536 742981	1		
CR 1- 3, 6-	DIODE, SI, BV=200V, IO=10A, DUAL, SOT89	742973	89536 742973	6	1	
CR 8		742973				
CR 4, 5	DIODE, SI, BV=75.0V, IO=100MA, MLF	742064	89536 742064	2	2	
CR 9, 10	DIODE, SI, SCHOTTKY, 30V, 1.1A, SOT89	782573	89536 782573	2	1	
F 1	FUSE, 5X20MM, FAST, 0.125A, 250V	573733	89536 573733	1	5	
J 1	HEADER, 1 ROW, 0.100CTR, 4 PIN	631184	89536 631184	1		
J 2, 3	HEADER, 1 ROW, 0.100CTR, 8 PIN	520502	22526 65502-408	2		
J 4, 6	CONN, DIN41612, TYPE R, 96 PIN	747808	89536 747808	2		
J 5	CONN, DIN41612, TYPE R, 64 PIN	782094	89536 782094	1		
J 7, 8	HEADER, 2 ROW, 0.100 CTR, 40 PIN	603670	89536 603670	2		
J 9	CONN, D-SUB, PWB, RT ANG, 25 SCKT	782144	89536 782144	1		
J 10	CONN, CIRC, DIN, RT ANG, PWB, 5 PIN @ 180	772178	89536 772178	1		
J 11	HEADER, 2 ROW, 0.100CTR, 20 PIN	782185	89536 782185	1		
J 14	HEADER, 2 ROW, 0.100CTR, 34 PIN	658047	89536 658047	1		
J 15	HEADER, 1 ROW, 0.156 CTR, 10 PIN	446724	27264 09-65-1101	1		
L 1, 2	CHOKO	502138	89536 502138	2		
Q 1, 2	* TRANSISTOR, SI, N-MOS, 1W, 4 PIN DIP	800391	89536 800391	2	1	
R 1	RES, CHIP, CERM, 56K, +-5%, 0.125W, 1206	746701	89536 746701	1		
R 2, 3, 6,	RES, CHIP, CERM, 10K, +-5%, 0.125W, 1206	746610	89536 746610	42		
R 7, 11- 15,		746610				
R 27- 29, 31-		746610				
R 35, 40, 43,		746610				
R 45- 48, 56-		746610				
R 63, 67, 70,		746610				
R 75, 76, 80,		746610				
R 83- 85, 87,		746610				
R 89, 90		746610				
R 4, 100-111,	RES, CHIP, CERM, 10, +-5%, 0.125W, 1206	746214	89536 746214	14		
R 116		746214				
R 5, 8- 10,	RES, CHIP, CERM, 4.7K, +-5%, 0.125W, 1206	740522	89536 740522	12		
R 21, 22, 30,		740522				
R 65, 69, 72,		740522				
R 82, 86		740522				
R 16, 17, 51-	RES, CHIP, CERM, 1.2K, +-5%, 0.125W, 1206	746412	89536 746412	10		
R 55, 71, 78,		746412				
R 88		746412				
R 18, 19, 36,	RES, CHIP, CERM, 39K, +-5%, 0.125W, 1206	746677	89536 746677	5		
R 37, 74		746677				
R 20, 38, 77	RES, CHIP, CERM, 3K, +-5%, 0.125W, 1206	746511	89536 746511	3		
R 23, 24	RES, CHIP, CERM, 390, +-5%, 0.125W, 1206	740498	89536 740498	2		
R 25, 26	RES, CHIP, CERM, 220, +-5%, 0.125W, 1206	746347	89536 746347	2		
R 39, 44, 79	RES, CHIP, CERM, 750, +-5%, 0.125W, 1206	746404	89536 746404	3		
R 41, 64, 66,	RES, CHIP, CERM, 33, +-5%, 0.125W, 1206	746248	89536 746248	9		
R 68, 91, 112-		746248				
R 115		746248				
R 42, 73	RES, CHIP, CERM, 100K, +-5%, 0.125W, 1206	740548	89536 740548	2		
R 49, 50	RES, CHIP, CERM, 510K, +-5%, 0.125W, 1206	746800	89536 746800	2		
R 81	RES, CHIP, CERM, 2.2K, +-5%, 0.125W, 1206	746479	89536 746479	1		
S 1	SWITCH, PUSHBUTTON, SPST, MOMENTARY	782433	89536 782433	1		
T 1	TRANSFORMER, CONVERTER	775932	89536 775932	1		
TP 1- 11	TERM, UNINSUL, WIRE FORM, TEST POINT	781237	89536 781237	11		
U 1, 4	* IC, BIPOLAR, DUAL RS-232 RECEIVER, SOIC	742395	89536 742395	2	1	
U 2, 3	* IC, BIPOLAR, DUAL RS-232 DRIVER, SOIC	742403	89536 742403	2	1	
U 5, 6	* ISOLATOR, HI-SPEED DUAL	742841	89536 742841	2	1	

An * in 'S' column indicates a static-sensitive part.

5/List of Replaceable Parts

Table 5-3. A1 Main PCA (cont.)

REFERENCE DESIGNATOR	FLUKE STOCK	MFRS SPLY	MANUFACTURERS PART NUMBER	TOT QTY	R O T	N S T
-A>-NUMERICS-----S-----DESCRIPTION-----	NO--	CODE-	OR GENERIC TYPE-----		-Q-	-E-
U 8, 35	* IC, LSTTL, HEX INVERTER, SOIC	741017	89536 741017	2	1	
U 9	* IC, CMOS, OCTL LINE DRVR, SOIC	742593	89536 742593	1	1	
U 10	* IC, LSTTL, 8BIT P/S-IN, S-OUT SHFT, SOIC	741983	89536 741983	1	1	
U 11	* IC, NMOS, EEPROM 2444	834416	89536 834416	1	1	
U 13- 16	* ASSEMBLY, RAM MODULE	809079	89536 809079	4		1
U 17	* IC, ALSTTL, 3-8 LINE DCDR W/ENABLE, SOIC	741686	89536 741686	1	1	
U 18	OSCILLATOR, 32MHZ, TTL CLOCK	742338	89536 742338	1		
U 19	* IC, FTTL, DUAL D F/F, +EDG TRG, SOIC	742163	89536 742163	1	1	
U 20	* IC, ASTTL, QUAD 2 INPUT NAND GATE, SOIC	782250	89536 782250	1	1	
U 21, 57	* IC, ALSTTL, QUAD 2 INPUT AND GATE, SOIC	741827	89536 741827	2	1	
U 22, 41, 82	* IC, LSTTL, QUAD 2 INPUT OR GATE, SOIC	740878	89536 740878	3	1	
U 23, 24	* IC, FTTL, 9 BIT PARITY GEN/CHECKER, SOIC	742478	89536 742478	2	1	
U 25, 91	* IC, ALSTTL, QUAD 2 INPUT NAND GATE, SOIC	782268	89536 782268	2	1	
U 26	* IC, LSTTL, 8-BIT BINARY CNTR W/REG, SOIC	782243	89536 782243	1	1	
U 27	* IC, LSTTL, OCTAL BUFFER INVERTED, SOIC	742627	89536 742627	1	1	
U 28	* IC, 16L8 LOGIC ARRAY	818203	89536 818203	1	1	
U 29- 31	* IC, ASTTL, QUAD 2-INPUT MUX, SOIC	811984	89536 811984	3	1	
U 32	* IC, NMOS, 16 BIT MICROPROCESSOR, PLCC	742429	89536 742429	1	1	
U 33	* IC, LSTTL, QUAD BUS, SOIC	740977	89536 740977	1	1	
U 34, 54	* IC, LSTTL, DUAL 4 INPUT NAND GATE, SOIC	742528	89536 742528	2	1	
U 36, 67, 74	* IC, ALSTTL, QUAD 2 INPUT NOR GATE, SOIC	782284	89536 782284	3	1	
U 37, 61- 63	* IC, LSTTL, OCTAL D F/F, +EDG TRG, SOIC	741975	89536 741975	4	1	
U 38, 89	* IC, ALSTTL, HEX INVERTERS, SOIC	782300	89536 782300	2	1	
U 39	* IC, ALSTTL, QUAD 2 INPUT OR GATE, SOIC	742460	89536 742460	1	1	
U 40, 50, 81	* IC, LSTTL, 8BIT S-IN, P-OUT R-SHFT, SOIC	742106	89536 742106	3	1	
U 42, 58	* IC, LSTTL, OCTL LINE DRVR, SOIC	742122	89536 742122	2	1	
U 43	* IC, NMOS, FLOPPY DISK FORMTR CNTLR, PLCC	782870	89536 782870	1	1	
U 44	* IC, NMOS, FLOPPY DISK INT CKT, PLCC	782888	89536 782888	1	1	
U 46	* PROGRAMMED 27256 V3.0	828897	89536 828897	1	1	
U 47	* PROGRAMMED 27256 V3.0	828905	89536 828905	1	1	
U 49, 75	* IC, LSTTL, 8 TO 3 LINE ENCODER, SOIC	782326	89536 782326	2	1	
U 51, 64	* IC, LSTTL, QUAD 2 INPUT NAND GATE, SOIC	741033	89536 741033	2	1	
U 52	* IC, LSTTL, TRIPLE 3-INPUT AND GATE, SOIC	741264	89536 741264	1	1	
U 53, 60	* IC, LSTTL, OCTAL D F/F, +EDG TRG, SOIC	740928	89536 740928	2	1	
U 55, 90	* IC, ALSTTL, 8 INPUT NAND GATE, SOIC	782334	89536 782334	2	1	
U 56, 65, 78	* IC, LSTTL, QUAD 2 INPUT NOR GATE, SOIC	741025	89536 741025	3	1	
U 59	* IC, COMPARATOR, QUAD, 14 PIN, SOIC	741561	89536 741561	1	1	
U 66	* IC, LSTTL, TRIPLE 3 INPUT NOR GATE, SOIC	740993	89536 740993	1	1	
U 68	* IC, ALSTTL, DUAL 4 INPUT NAND GATE, SOIC	741645	89536 741645	1	1	
U 69	* IC, ALSTTL, TRIPLE 3INPUT NOR GATE, SOIC	782318	89536 782318	1	1	
U 70	* IC, LSTTL, 2-4 LINE DEMUX, SOIC	740951	89536 740951	1	1	
U 71	* IC, CMOS, HEX INVERTER W/SCHT TRIG, SOIC	780965	89536 780965	1	1	
U 72	* IC, TTL, HEX BUFFER W/OPEN COLL, SOIC	742387	89536 742387	1	1	
U 73	* IC, LSTTL, DUAL JK F/F, -EDG TRIG, SOIC	741256	89536 741256	1	1	
U 76	* IC, LSTTL, QUAD 2IN O/C NAND GATE, SOIC	782292	89536 782292	1	1	
U 77, 80	* IC, LSTTL, DUAL D F/F, +EDG TRG, SOIC	740985	89536 740985	2	1	
U 79	* IC, ALSTTL, DUAL D F/F, +EDG TRG, SOIC	742452	89536 742452	1	1	
U 83	SWITCH, MODULE, SPST, DIP, 8 POS	414490	00779 435166-5	1		
U 84	* IC, LSTTL, QUAD 2 INPUT AND GATE, SOIC	740860	89536 740860	1	1	
U 85	* IC, LSTTL, DUAL J-F F/F, +EDG TRIG, SOIC	742502	89536 742502	1	1	
U 86	* IC, LSTTL, DELAY ELEMENTS, SOIC	773077	89536 773077	1	1	
U 87	* IC, VOLT SUPERVISOR, 10V SENSE, SOIC	780502	89536 780502	1	1	
U 88	* IC, LSTTL, MONOSTAB MULTIVB W/CLR, SOIC	742494	89536 742494	1	1	
XF 1	HOLDER, FUSE, 5X20MM, PCB	772475	89536 772475	2		
XU 13- 16	CONN, PWB EDGE, REC, 0.100CTR, 30 POS	806828	89536 806828	4	1	
XU 18	SPACER, DIP SOCKET, 14 PIN, PLASTIC	441865	32559 814-060	1		
XU 28	SOCKET, IC, 20 PIN	454421	09922 DILB20P-108	1		
XU 45- 48	SOCKET, IC, 28 PIN	448217	91506 328-AG39D	4		
Y 1	CRYSTAL, 3.6864MHZ, +/-50PPM, SURF.MNT.	800193	89536 800193	1	1	

An * in 'S' column indicates a static-sensitive part.

NOTES:

1 - See A16 on the Final Assembly for quantities and part numbers.

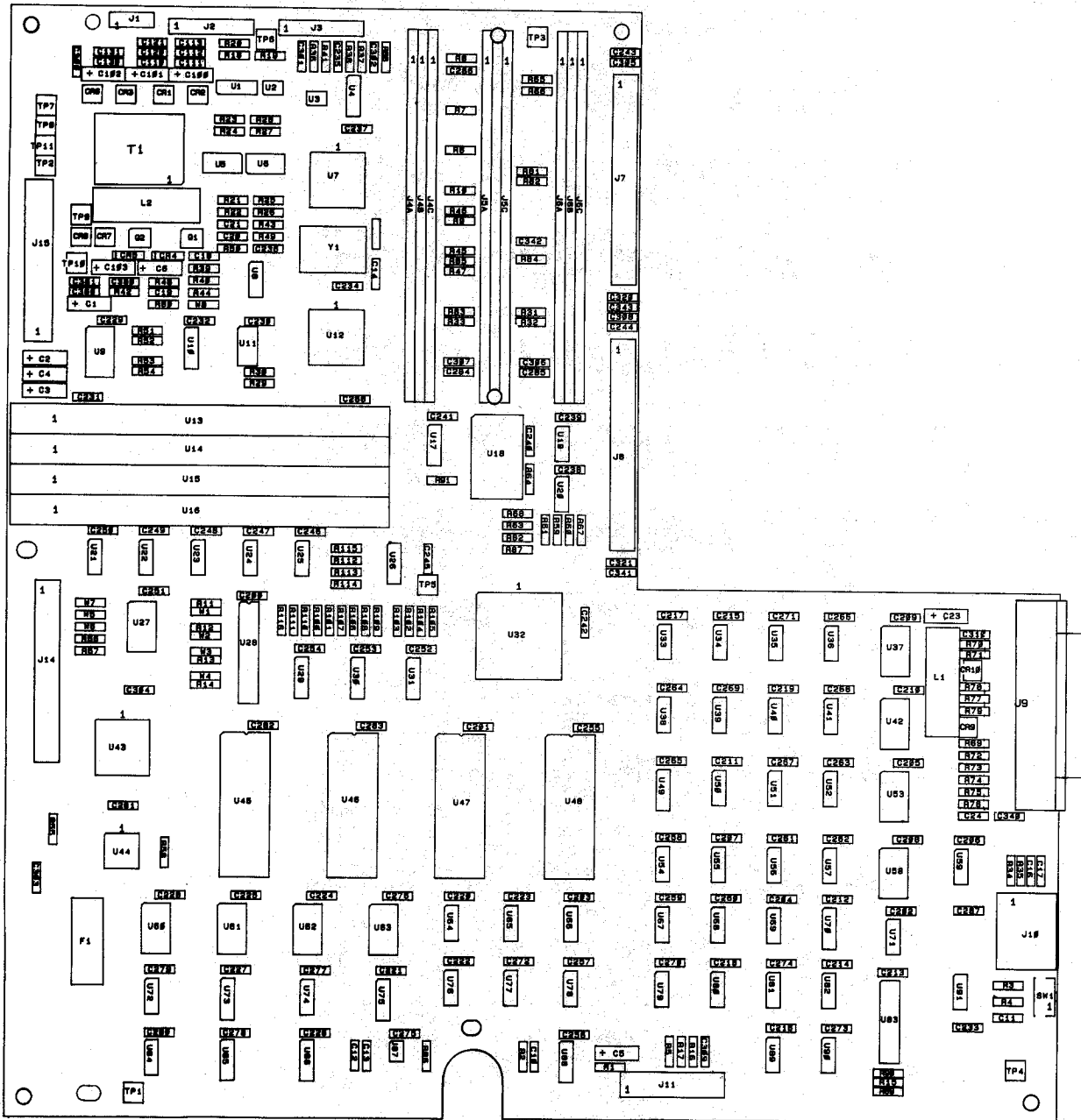

 **CAUTION**
SUBJECT TO DAMAGE BY
STATIC ELECTRICITY

9100A-1601

Figure 5-2. A1 Main PCA

5/List of Replaceable Parts

Table 5-4. A2 Display Interface PCA
(See Figure 5-3.)

REFERENCE DESIGNATOR	FLUKE STOCK	MFRS SPLY	MANUFACTURERS PART NUMBER	TOT QTY	R O T
-A>-NUMERIC->	DESCRIPTION	-NO--	-OR GENERIC TYPE--	-Q-	-E-
C 1, 8	CAP, CER, 5.6PF, +-10%, 50V, COG, 1206	782409	89536 782409	2	
C 2	CAP, TA, 1.5UF, +-20%, 50V	780478	89536 780478	1	1
C 3, 4	CAP, TA, 10UF, +-20%, 25V	772491	89536 772491	2	
C 5, 70- 78,	CAP, CER, 0.01UF, +-20%, 100V, X7R, 1206	742981	89536 742981	41	
C 101-131		742981			
C 6, 7	CAP, CER, 0.1UF, +-10%, 25V, X7R, 1206	747287	89536 747287	2	
CR 1- 7	* LED, RED, RECTANGLE, PCB MOUNT	504761	14936 MV57124	7	2
E 1	AF TRANSD, PIEZO, 24 MM	602490	51406 EFB-RD24C01	1	
J 1, 2	HEADER, 2 ROW, 0.100CTR, 20 PIN	782185	89536 782185	2	
MP 1	DISPLAY ALIGNMENT FIXTURE	788570	89536 788570	1	
Q 1- 4	TRANSISTOR, SI, PNP, SMALL SIGNAL, SOT23	742023	89536 742023	4	1
Q 5- 8	TRANSISTOR, SI, NPN, SMALL SIGNAL, SOT23	742031	89536 742031	4	1
R 1- 4, 6-	RES, CHIP, CERM, 1.1K, +-5%, 0.125W, 1206	746008	89536 746008	16	
R 13, 15, 16,		746008			
R 48, 49		746008			
R 5	RES, CHIP, CERM, 100K, +-5%, 0.125W, 1206	740548	89536 740548	1	
R 14, 17	RES, CHIP, CERM, 6.8K, +-5%, 0.125W, 1206	746024	89536 746024	2	
R 18, 19	RES, CHIP, CERM, 620, +-5%, 0.125W, 1206	745984	89536 745984	2	
R 20	RES, CHIP, CERM, 330, +-5%, 0.125W, 1206	746370	89536 746370	1	
R 21	RES, CHIP, CERM, 470, +-5%, 0.125W, 1206	740506	89536 740506	1	
R 22- 29	RES, CHIP, CERM, 10K, +-5%, 0.125W, 1206	746610	89536 746610	8	
R 30, 31	RES, CHIP, CERM, 6.2K, +-5%, 0.125W, 1206	746016	89536 746016	2	
R 32, 42- 47	RES, CHIP, CERM, 180, +-5%, 0.125W, 1206	746321	89536 746321	7	
R 33, 34, 41,	RES, CHIP, CERM, 4.7K, +-5%, 0.125W, 1206	740522	89536 740522	4	
R 50		740522			
R 35, 36	RES, CHIP, CERM, 100, +-5%, 0.125W, 1206	746297	89536 746297	2	
R 37	RES, CHIP, CERM, 3K, +-5%, 0.125W, 1206	746511	89536 746511	1	
R 38	RES, CHIP, CERM, 7.5K, +-5%, 0.125W, 1206	746586	89536 746586	1	
R 39	RES, CHIP, CERM, 2K, +-5%, 0.125W, 1206	746461	89536 746461	1	
R 40	RES, CHIP, CERM, 1.8K, +-5%, 0.125W, 1206	746453	89536 746453	1	
TP 1- 7	TERM, UNINSUL, WIRE FORM, TEST POINT	781237	89536 781237	7	
U 1	* IC, NMOS, 8 BIT MICROCOMP W/SOCKET	800607	89536 800607	1	1
U 1	* PROGRAMMED 2732-2 V1.0	818187	89536 818187	1	1
U 2	* IC, LSTTL, OCTAL D F/F, +EDG TRG, SOIC	741975	89536 741975	1	1
U 3	* IC, 2K X 8 STATIC RAM, 120NSEC, SOIC	742783	89536 742783	1	2
U 4	* IC, LSTTL, DUAL DIV BY 2, 5 CNTR, SOIC	741967	89536 741967	1	1
U 5- 12	* IC, BIMOS, DISPLAY DRIVER, 80V, PLCC	741231	89536 741231	8	2
U 13, 14	* IC, LSTTL, DUAL D F/F, +EDG TRG, SOIC	740985	89536 740985	2	1
U 15, 27	* IC, ALSTTL, DUAL JK F/F, -EDG TRG, SOIC	807578	89536 807578	2	1
U 16	* IC, LSTTL, QUAD 2 INPUT NAND GATE, SOIC	741033	89536 741033	1	1
U 17, 31	* IC, LSTTL, QUAD 2 INPUT NOR GATE, SOIC	741025	89536 741025	2	1
U 18	* IC, CMOS, HEX INVERTER, SOIC	742585	89536 742585	1	1
U 19, 20	* IC, LSTTL, TRIPLE 3-INPUT AND GATE, SOIC	741264	89536 741264	2	1
U 21	* IC, LSTTL, QUAD 2 INPUT OR GATE, SOIC	740878	89536 740878	1	1
U 22	* IC, TTL, HEX INVERTER, W/OPEN COLL, SOIC	741249	89536 741249	1	1
U 23, 24	* IC, CMOS, 8 BIT P/S-IN, S-OUT SHFT, SOIC	782904	89536 782904	2	1
U 25, 30	* IC, ALSTTL, OCTAL D F/F, +EDG TRG, SOIC	741769	89536 741769	2	1
U 26	* IC, LSTTL, BCD-DEC, DECODER/DRIVER, SOIC	742007	89536 742007	1	1
U 28	* IC, LSTTL, DIV BY 16 BINARY COUNTR, SOIC	741991	89536 741991	1	1
U 29	* IC, BPLR, DUAL TIMER, SOIC	741959	89536 741959	1	1
VF 1	TUBE, DISPLAY, VAC FLUOR, PATTERN DIS	742056	89536 742056	1	
VR 1- 2	ZENER, UNCOMP, 3.3V, 5%, 76MA, 1W, MLF	800599	89536 800599	2	1
XU 1	SOCKET, IC, 40 PIN	429282	09922 DILB40P-108	1	
Y 1	CRYSTAL, 9.8304MHZ, +-50PPM, SURFACE MT.	800383	89536 800383	1	

An * in 'S' column indicates a static-sensitive part.

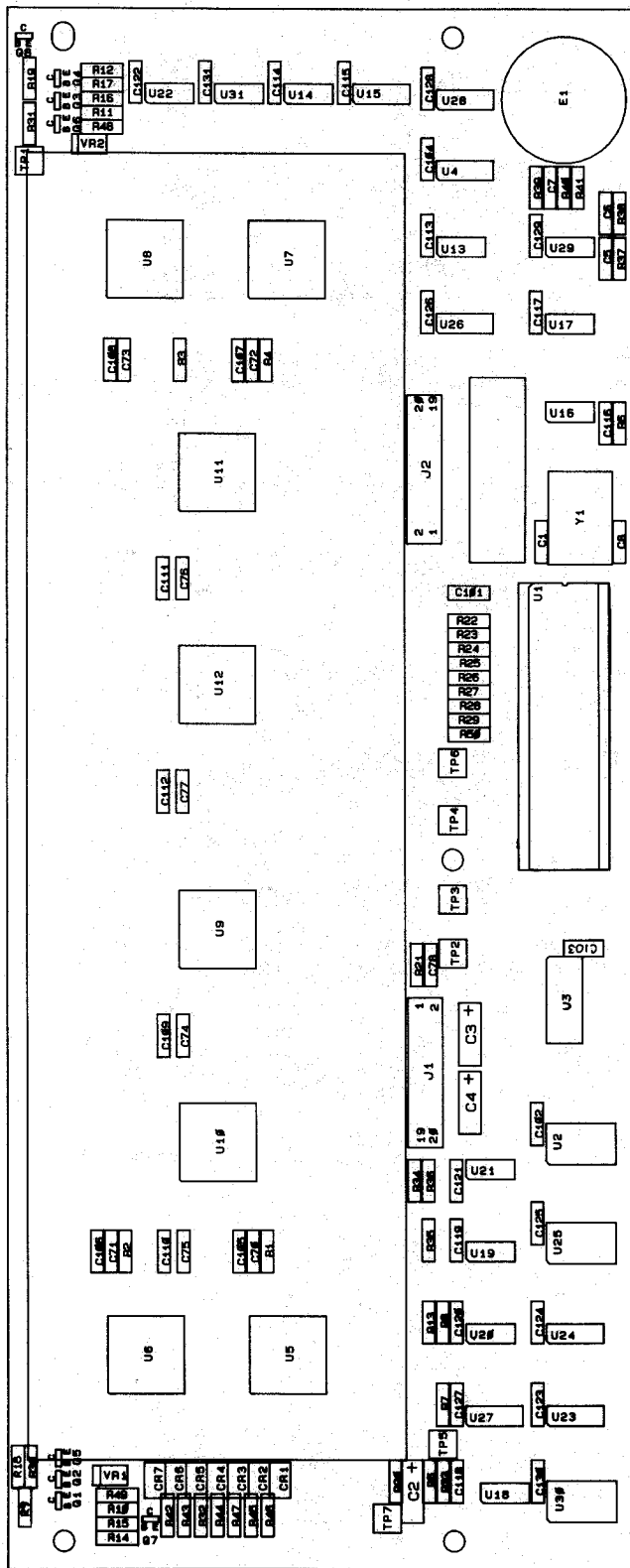

9100A-1602

Figure 5-3. A2 Display Interface PCA

5/List of Replaceable Parts

Table 5-5. A4 Video Controller PCA
(See Figure 5-4.)

REFERENCE DESIGNATOR	FLUKE STOCK	MFRS SPLY	MANUFACTURERS PART NUMBER	TOT QTY	R S T	N O E
-A>-NUMERICS-----> S-----DESCRIPTION-----	--NO--	-CODE-	-OR GENERIC TYPE-----	QTY-	-Q-	-E-
C 1, 101-131	747261	89536	747261	32		
C 2, 8	747287	89536	747287	2		
C 3, 7	772491	89536	772491	2	1	
C 4- 6	769240	89536	769240	3		
C 9, 10	740589	89536	740589	2		
H 1	183574	89536	183574	2		
J 1	782102	89536	782102	1		
J 2	782789	89536	782789	1		
Q 1	742676	89536	742676	1	1	
Q 2	742684	89536	742684	1	1	
R 1- 5, 14, 15	746370	89536	746370	7		
R 6, 13	746388	89536	746388	2		
R 7- 11	769828	89536	769828	5		
R 12	745992	89536	745992	1		
R 16	740506	89536	740506	1		
R 17	746263	89536	746263	1		
R 18	746347	89536	746347	1		
R 19	746495	89536	746495	1		
R 20	746446	89536	746446	1		
R 21	746560	89536	746560	1		
R 22, 23	746230	89536	746230	2		
R 24, 25	746610	89536	746610	2		
TP 1- 10	781237	89536	781237	10		
U 1	742734	89536	742734	1	1	
U 2	742742	89536	742742	1	1	
U 3, 4	742783	89536	742783	2	1	
U 5	818195	89536	818195	1	1	
U 6- 8	773028	89536	773028	3	1	
U 9, 10	742122	89536	742122	2	1	
U 11, 12	742726	89536	742726	2	1	
U 13	741975	89536	741975	1	1	
U 14	742619	89536	742619	1	1	
U 15	742700	89536	742700	1	1	
U 16- 19	741033	89536	741033	4	1	
U 20, 21	741264	89536	741264	2	1	
U 22	741017	89536	741017	1	1	
U 23	742510	89536	742510	1	1	
U 24	807578	89536	807578	1	1	
U 25	742692	89536	742692	1	1	
U 26	740860	89536	740860	1	1	
U 27	742627	89536	742627	1	1	
U 28	418285	28480	5082-4364	1	1	
U 29- 31	742817	89536	742817	3	1	
XU 5	448217	91506	328-AG39D	1		
XY 1	441865	32559	814-060	1		
XZ 1, 2	276535	91506	316-AG39D	2		
Y 1	800029	89536	800029	1		

An * in 'S' column indicates a static-sensitive part.

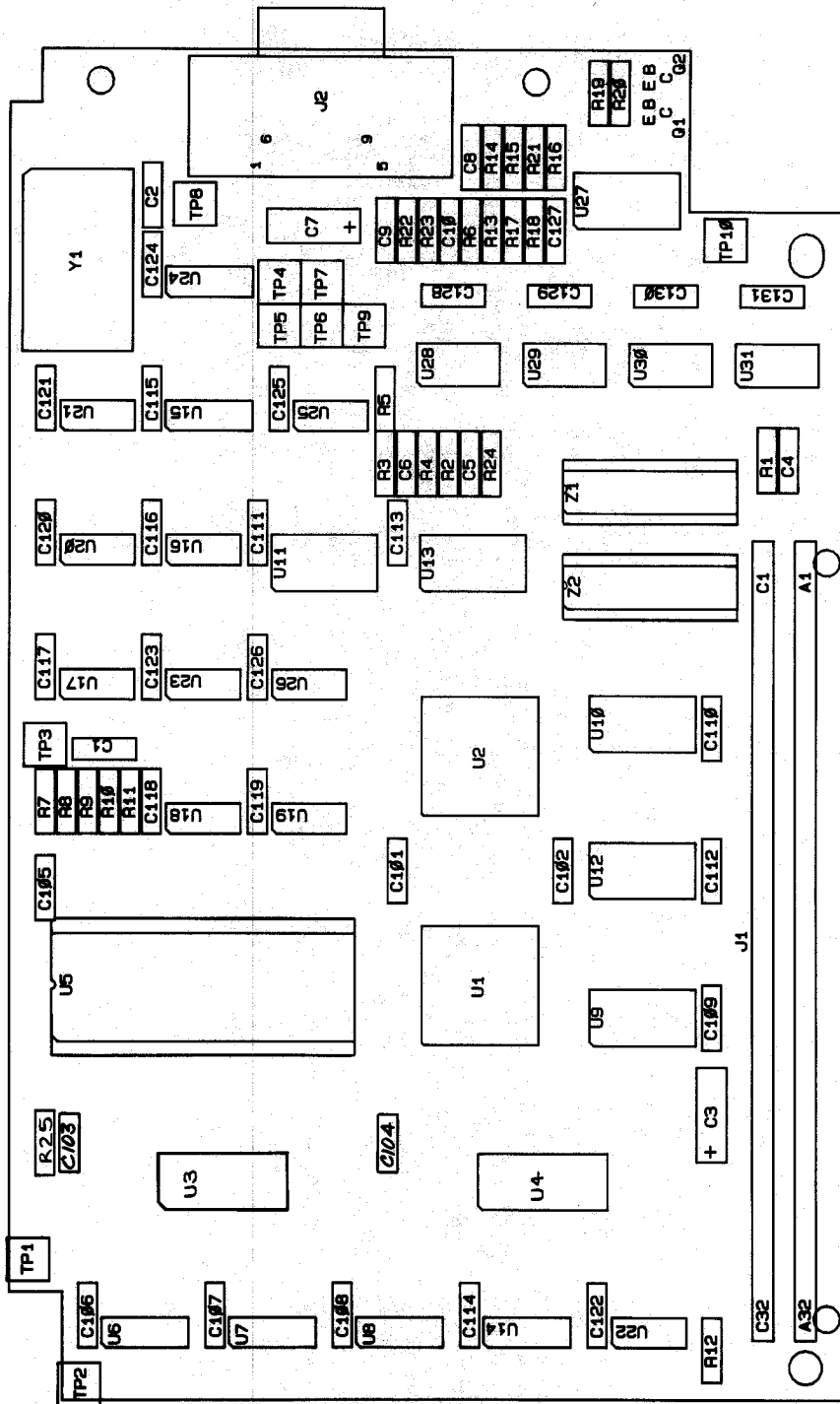

9100A-1604

Figure 5-4. A4 Video Controller PCA

5/List of Replaceable Parts

Table 5-6. A5 Probe Assembly
(See Figure 5-5.)

REFERENCE DESIGNATOR		FLUKE STOCK	MFRS SPLY	MANUFACTURERS PART NUMBER	TOT QTY	N R O S T -O -E-
-A>-NUMERICS----->	S-----DESCRIPTION-----	--NO--	-CODE-	-OR GENERIC TYPE-----		
C 1	CAP, CER, 27PF, +-10%, 50V, COG, 1206	800508	89536	800508	1	
C 2, 5	CAP, CER, 1000PF, +-10%, 50V, COG, 1206	747378	89536	747378	2	
C 3, 4	CAP, CER, 0.22UF, +80-20%, 50V, Y5V, 1206	740597	89536	740597	2	
C 6	CAP, CER, 0.22UF, +80-20%, 50V, Y5V, 1206	740597	89536	740597	1	
CR 1- 4	DIODE, SI, BV=75.0V, IO=100MA, MLF	742064	89536	742064	4	1
CR 5	DIODE, SI, BV=75.0V, IO=100MA, MLF	742064	89536	742064	1	1
L 1- 3	LAMP, SUB-MIN, 5V, 20MA	836239	89536	836239	3	5
MP 1	CONNECTOR, GROUND CLIP, FINISHED	788026	89536	788026	1	1
MP 2	COVER, PROBE	773309	89536	773309	1	
MP 3	KEYTOP	773333	89536	773333	1	
MP 4	BODY, PROBE	773317	89536	773317	1	
MP 5	DECAL, PROBE CONNECTOR	773929	89536	773929	1	
Q 1, 2	TRANSISTOR, SI, PNP, SMALL SIGNAL, SOT23	742023	89536	742023	2	1
Q 3, 4	TRANSISTOR, SI, NPN, SMALL SIGNAL, SOT23	742031	89536	742031	2	1
R 1	RES, CHIP, CERM, 220, +-5%, 0.125W, 1206	746347	89536	746347	1	
R 2	RES, CHIP, CERM, 100K, +-1%, 0.125W, 1206	769802	89536	769802	1	1
R 3, 8, 10	RES, CHIP, CERM, 200, +-5%, 0.125W, 1206	746339	89536	746339	3	
R 4	RES, CHIP, CERM, 330, +-5%, 0.125W, 1206	746370	89536	746370	1	
R 5, 7	RES, CHIP, CERM, 470, +-5%, 0.125W, 1206	740506	89536	740506	2	
R 6	RES, CHIP, CERM, 470, +-5%, 0.125W, 1206	740506	89536	740506	1	
R 9	RES, CHIP, CERM, 205K, +-1%, 0.125W, 1206	769836	89536	769836	1	1
R 11- 13	RES, CHIP, CERM, 1K, +-5%, 0.125W, 1206	745992	89536	745992	3	
S 1	SWITCH, PUSHBUTTON, SPST, MOMENTARY	782656	89536	782656	1	3
U 1	* IC, FTTL, HEX INVERT W/SCHMT TRIG, SOIC	742825	89536	742825	1	1
W 1	WIRE, TEF, E, 28AWG, STRN, BLU	558320	89536	558320	1	
W 2	CABLE ASSY, PROBE	783951	89536	783951	1	

An * in 'S' column indicates a static-sensitive part.

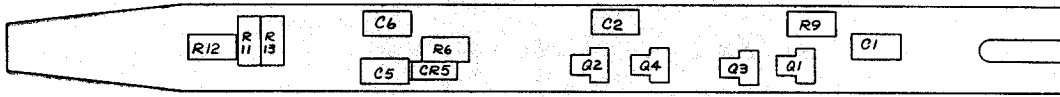

CKT 1

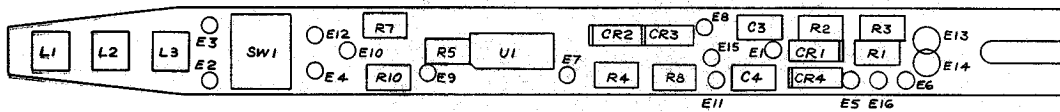

CKT 2

9100A-1605

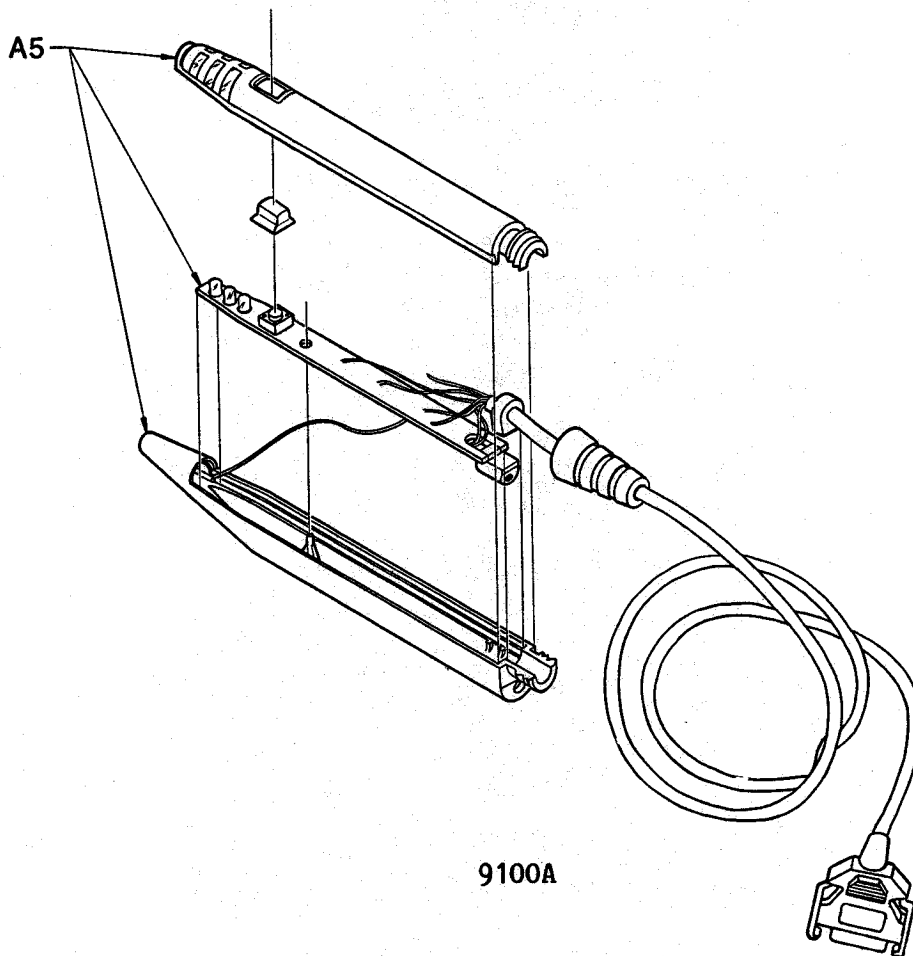

9100A

Figure 5-5. A5 Probe PCA

5/List of Replaceable Parts

Table 5-7. A6 Clock Module PCA
(See Figure 5-6.)

REFERENCE DESIGNATOR	FLUKE STOCK	MFRS SPLY	MANUFACTURERS PART NUMBER	TOT QTY	N R S T
-A>-NUMERICS--> S-----DESCRIPTION-----	--NO--	-CODE-	-OR GENERIC TYPE-----	-Q-	-E-
C 1- 4					
C 5- 12, 14	747303	89536	747303	4	
C 13	747261	89536	747261	9	
CR 1- 4	772491	89536	772491	1	
F 1	742320	89536	742320	4	
F 1	109314	71400	AGC1-4	1	5
F 1	543504	71400	GMA1-4	1	5
J 1- 5	233411	00779	60599-3	5	
J 6	417030	89536	417030	1	
MP 1	460238	61935	031.1666	1	
MP 1	461020	89536	461020	1	
R 1- 8	746651	89536	746651	8	
R 9- 12	769752	89536	769752	4	
R 13, 24- 27	746297	89536	746297	5	1
R 14	769745	89536	769745	1	
R 15- 22	746370	89536	746370	8	
R 23	746610	89536	746610	1	
U 1, 2	782219	89536	782219	2	1
XF 1	602763	89536	602763	1	
XU 1, 2	276535	91506	316-AG39D	2	

An * in 'S' column indicates a static-sensitive part.

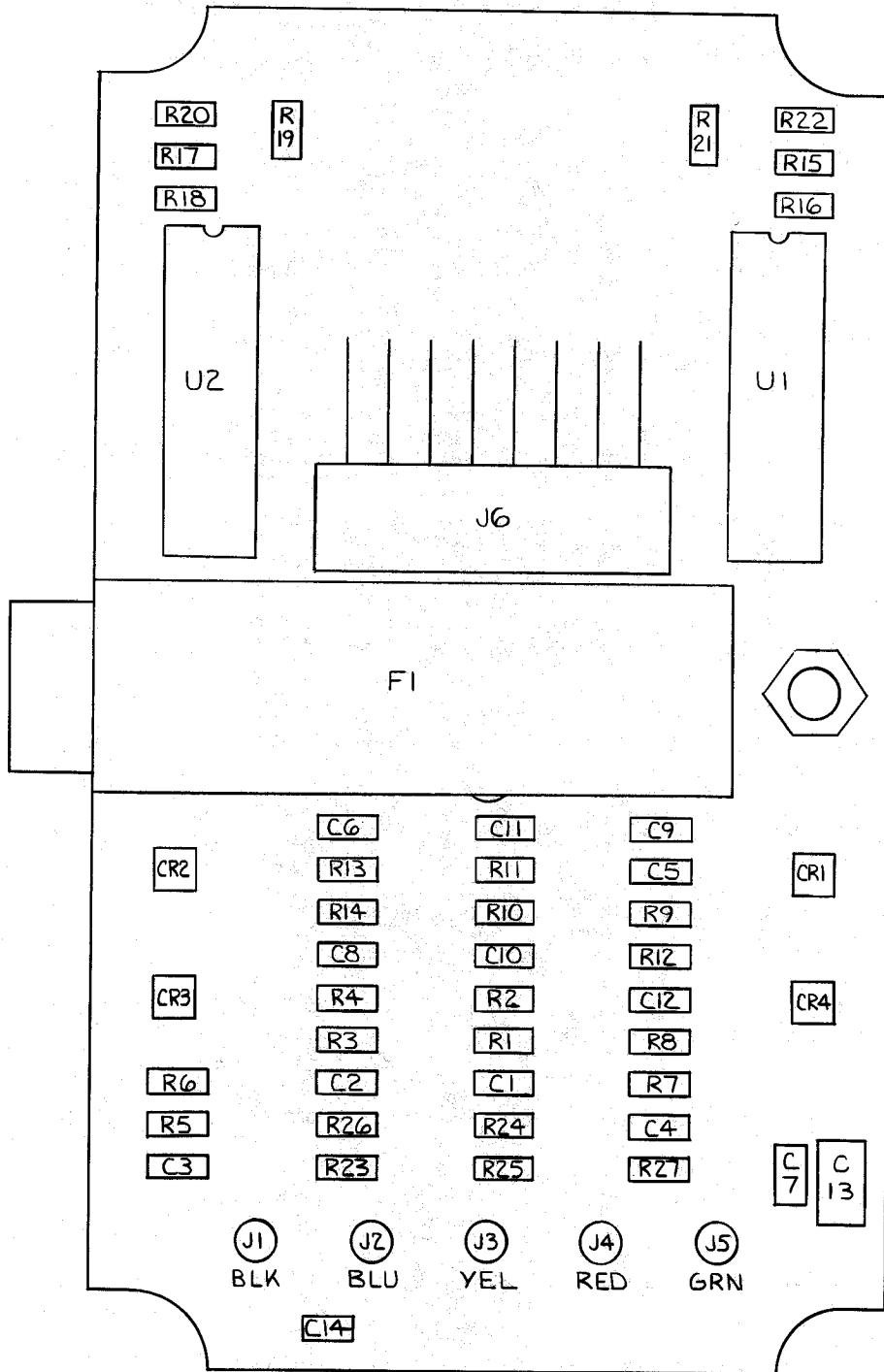

9100A-1606

Figure 5-6. A6 Clock Module PCA

5/List of Replaceable Parts

Table 5-8. A7 I/O Module Main PCA
(See Figure 5-7.)

REFERENCE DESIGNATOR	FLUKE STOCK	MFRS SPLY	MANUFACTURERS PART NUMBER	TOT QTY	R S T	N O T
-A>-NUMERICS--> S-----DESCRIPTION-----	--NO--	-CODE-	-OR GENERIC TYPE-----		-Q-	-E-
C 1, 2, 9-	772491	89536	772491	27		
C 24, 27, 37,	772491					
C 42- 44, 61,	772491					
C 62, 67, 68	772491					
C 3- 7, 28-	747261	89536	747261	31		
C 36, 38, 39,	747261					
C 46- 60	747261					
C 45	747287	89536	747287	1		
CR 1- 4, 7,	742320	89536	742320	85	5	
CR 100-179	742320					
CR 5, 6	742064	89536	742064	2	1	
CR 8	782573	89536	782573	1	1	
E 1- 5	233411	00779	60599-3	5		
F 1	109272	89536	109272	1	5	
F 1	808055	89536	808055	1	5	
H 1	178533	89536	178533	1		
J 1	782748	89536	89536	1		
J 2, 3	783795	89536	783795	2		
MP 1	104448	89536	104448	1		
P 1	783803	89536	783803	1		
Q 1, 2	742684	89536	742684	2	1	
R 1, 2	746297	89536	746297	2		
R 3, 5, 6,	769794	89536	769794	4		
R 10	769794					
R 4, 9	769851	89536	769851	2		
R 7	811463	89536	811463	1		
R 8	811455	89536	811455	1		
R 13, 14	746602	89536	746602	2		
R 15, 17	769299	89536	769299	2		
R 16, 18	769257	89536	769257	2		
R 19, 20, 23-	740522	89536	740522	10		
R 30	740522					
R 21, 22, 31,	745992	89536	745992	7		
R 33, 34, 39,	745992					
R 40	745992					
R 32	769752	89536	769752	1		
TP 1- 8	781237	89536	781237	8		
U 1	634113	89536	634113	1		
U 2	742569	89536	742569	1	1	
U 3, 5	740860	89536	740860	2	1	
U 4	742585	89536	742585	1	1	
U 6	740969	89536	740969	1	1	
U 7	742726	89536	742726	1	1	
U 8	742577	89536	742577	1	1	
U 9	801274	89536	801274	1	1	
U 10	740878	89536	740878	1	1	
U 11, 12	741256	89536	741256	2	1	
U 13, 16, 17	742593	89536	742593	3	2	
U 14	740928	89536	740928	1	1	
U 15	742510	89536	742510	1	1	
U 18	780767	89536	780767	1	1	
U 100,110,120,	760785	89536	760785	5	1	
U 130,140	760785					
U 101,103,111,	800185	89536	800185	10	2	
U 113,121,123,	800185					
U 131,133,141,	800185					
U 143	800185					
U 102,104,112,	782557	89536	782557	10	2	
U 114,122,124,	782557					
U 132,134,142,	782557					
U 144	782557					
U 105,106,115,	801043	89536	801043	10	1	
U 116,125,126,	801043					
U 135,136,145,	801043					
U 146	801043					
XF 1	602763	89536	602763	1		
XY 1	441865	32559	814-060	1		
Z 1,100,110,	780460	89536	780460	6	1	
Z 120,130,140	780460					

An * in 'S' column indicates a static-sensitive part.

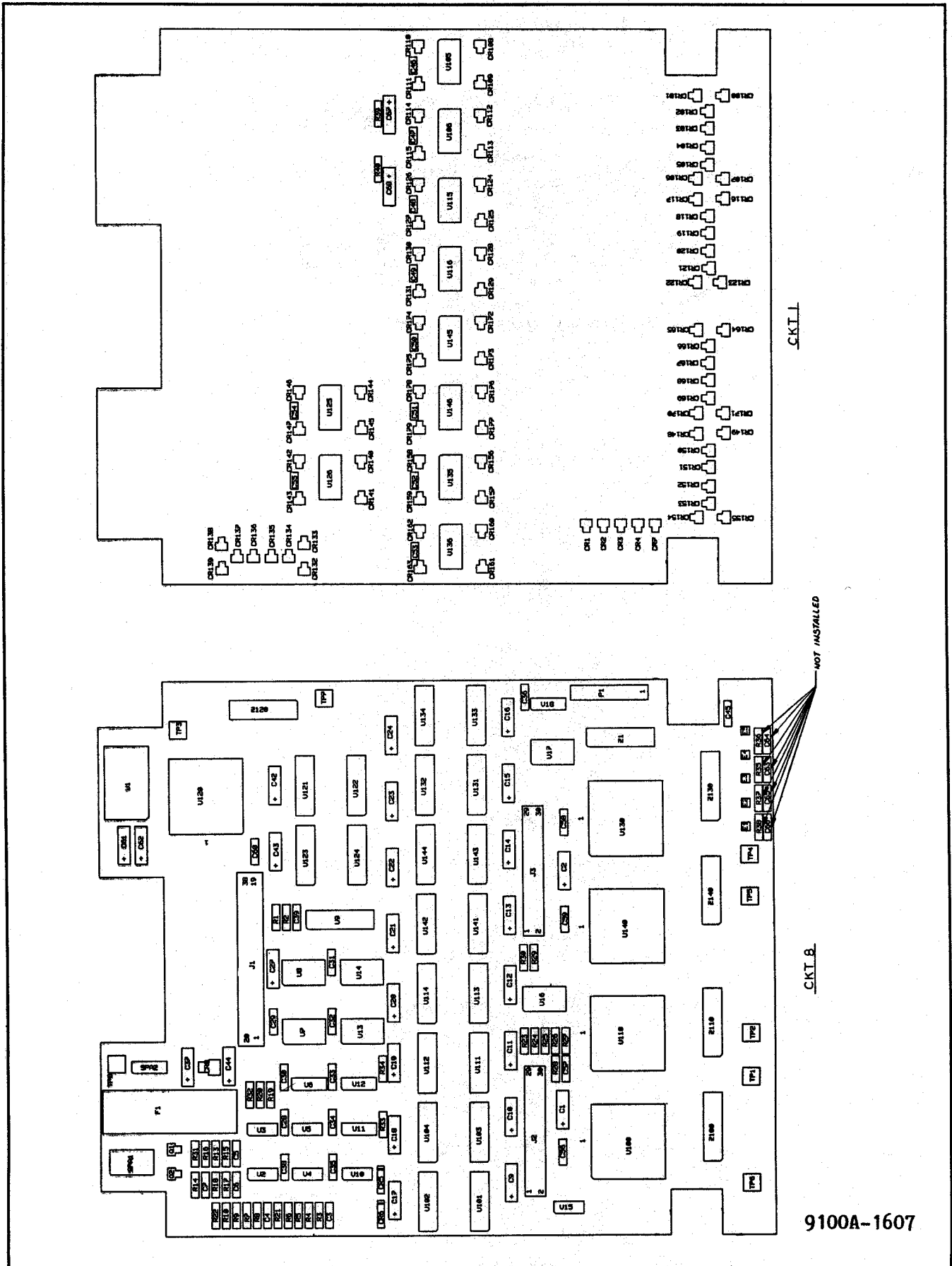

Figure 5-7. A7 I/O Module (Main) PCA

9100A-1607

5/List of Replaceable Parts

Table 5-9. A8 I/O Module (Top) PCA
(See Figure 5-8.)

REFERENCE DESIGNATOR			FLUKE STOCK	MFRS SPLY	MANUFACTURERS PART NUMBER	TOT	R	N
-A>-NUMERICS-->	S	-----DESCRIPTION-----	--NO--	-CODE-	-OR GENERIC TYPE-----	QTY-	-Q-	-E-
C	1- 4	CAP, AL, 4700UF, +-20%, 16V, SOLV PROOF	800904	89536	800904	4	1	
CR	1- 4	* DIODE, SI, 100 PIV, 1.0 AMP	343491	01295	1N4002	4	1	
H	1	SCREW, MACH, PHP SEMS, STL, 6-32X1/4	178533	89536	178533	2		
H	2	SCREW, MACH, PHP SEMS, STL, 4-40X3/16	732750	89536	732750	4		
J	1, 4	HEADER, 2 ROW, 0.100CTR, 30 PIN	801233	89536	801233	2		
J	2, 3	CONN, RECT, PWB, REC, 33 POS	800672	89536	800672	2		
MP	1	COVER, SHIELD I/O MODULE	768036	89536	768036	1		
MP	2	SPACER, SWAGED, RND, BRASS, 6-32X0.590	811224	89536	811224	5		
MP	3	SPACER, SWAGED, RND, BRASS, 6-32X0.250	446351	89536	446351	2		
P	1- 4	GUIDE SOCKET	805648	89536	805648	4		

An * in 'S' column indicates a static-sensitive part.

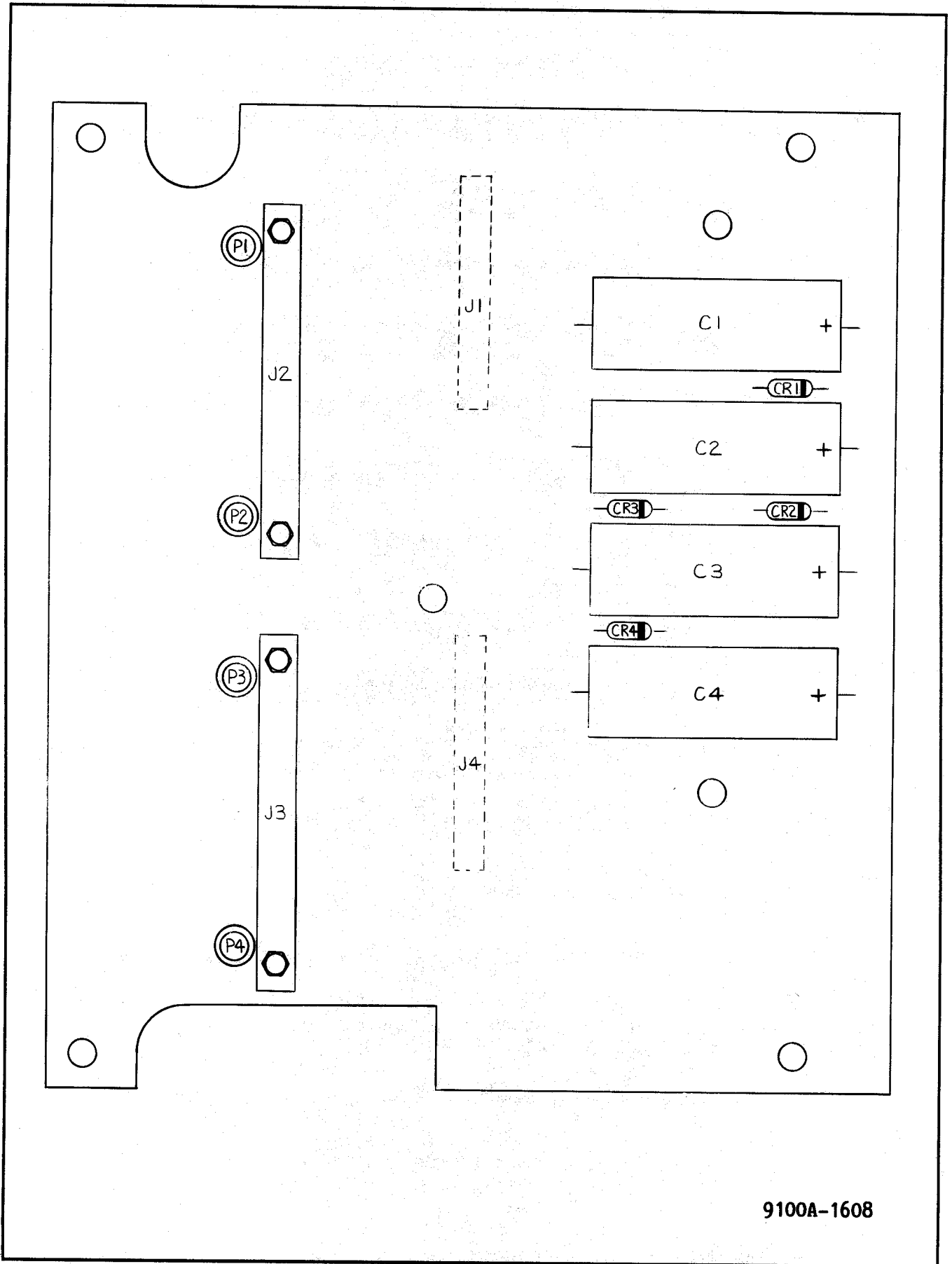

9100A-1608

Figure 5-8. A8 I/O Module (Top) PCA

5/List of Replaceable Parts

Table 5-10. A9 Probe I/O Interface PCA
(See Figure 5-9.)

REFERENCE DESIGNATOR	FLUKE STOCK	MFRS SPLY CODE	MANUFACTURERS PART NUMBER OR GENERIC TYPE	TOT QTY	R O S T
-A>-NUMERICS-----> S-----DESCRIPTION-----> --NO--		-CODE-			-Q--E-
C 1, 3, 4,					
C 8- 11, 16,					
C 17, 19, 21,					
C 23, 25- 33,					
C 39, 40					
C 2					
C 5, 7, 20,					
C 22, 24, 35					
C 6, 14, 18					
C 12					
C 13					
C 15					
C 34					
C 36					
C 37, 38					
C 41, 42					
CR 1- 6, 8,					
CR 11					
CR 7, 9, 10					
CR 12					
F 1					
F 1					
J 1					
J 2					
J 3					
J 4					
J 5					
J 6, 7					
MP 1					
MP 1					
Q 1					
Q 2, 6, 7,					
Q 9					
Q 3, 4, 5,					
Q 8					
Q 10, 11					
R 1					
R 2					
R 3- 6, 48,					
R 49					
R 7					
R 8					
R 9					
R 10- 12, 14,					
R 21, 28					
R 13, 15					
R 16, 46, 51,					
R 59					
R 17, 20, 26,					
R 31, 36, 41,					
R 54, 78					
R 18, 22, 23,					
R 27, 32- 34,					
R 37, 38, 42,					
R 52, 53, 55,					
R 56, 58, 61-					
R 63, 67, 72,					
R 80, 82, 86					
R 19, 35, 84,					
R 85					
R 24, 29, 30					
R 25					
R 39					
R 40, 43, 45,					
R 47, 79, 81					
R 44					
R 50, 57					
R 60					
R 64					
R 65					

An * in 'S' column indicates a static-sensitive part.

5/List of Replaceable Parts

Table 5-10. A9 Probe I/O Interface PCA (cont.)

REFERENCE DESIGNATOR	FLUKE STOCK	MFRS SPLY	MANUFACTURERS PART NUMBER	TOT QTY	R S T	N O T
-A>-NUMERICS--> S	DESCRIPTION	--NO--	-OR CODE- -OR GENERIC TYPE----	QTY-	-Q	-E-
R 68, 75	RES,CHIP,CERM,30.1K,+1%,0.125W,1206	801258	89536 801258	2		
R 69	RES,CHIP,CERM,47,+5%,0.125W,1206	746263	89536 746263	1		
R 70	RES,CHIP,CERM,3.4K,+1%,0.125W,1206	769844	89536 769844	1		
R 71, 74, 76,	RES,CHIP,CERM,10K,+1%,0.125W,1206	769794	89536 769794	4		
R 77		769794				
R 73	RES,CHIP,CERM,620,+5%,0.125W,1206	745984	89536 745984	1		
R 83	RES,CF,2.2,+5%,0.25W	354944	80031 CR251-4-5P2E2	1	1	
R 87	RES,CHIP,CERM,1.30K,+1%,0.125W,1206	780999	89536 780999	1		
R 88	RES,CHIP,CERM,243,+1%,0.125W,1206	810606	89536 810606	1	1	
R 90	RES,CHIP,CERM,22,+5%,0.125W,1206	746230	89536 746230	1		
TP 1- 7	TERM,UNINSUL,WIRE FORM,TEST POINT	781237	89536 781237	7		
U 1	ISOLATOR, 20 MHZ OPTOCOUPLER	742817	89536 742817	1	1	
U 2	* IC,FTTL,QUAD 2 INPUT XOR GATE,SOIC	742171	89536 742171	1	1	
U 3	* IC,LSTTL,QUAD 2 INPUT NOR GATE,SOIC	741025	89536 741025	1	1	
U 4, 12	* IC,FTTL,HEX INVERTER,SOIC	742148	89536 742148	2	1	
U 5	* IC,FTTL,QUAD DUAL AND GATE,SOIC	780957	89536 780957	1	1	
U 6	* IC,CMOS,HEX INVERTER W/SCHT TRIG,SOIC	780965	89536 780965	1	1	
U 7, 13	* IC,LSTTL,QUAD 2 INPUT OR GATE,SOIC	740878	89536 740878	2	1	
U 8	* IC,LSTTL,2-4 LINE DEMUX,SOIC	740951	89536 740951	1	1	
U 9	* IC,FTTL,QUAD 2-1 LINE MUX,SOIC	773028	89536 773028	1	1	
U 10	* IC,FTTL,DUAL D F/F,+EDG TRG,SOIC	742163	89536 742163	1	1	
U 11	* IC,FTTL,QUAD 2 INPUT OR GATE,SOIC	743237	89536 743237	1	1	
U 14, 15	* IC,LSTTL,OCTL LINE DRVR,SOIC	742122	89536 742122	2	1	
U 16	* IC,FTTL,DUAL 4-1 LINE MUX,SOIC	772806	89536 772806	1	1	
U 17	* IC,LSTTL,QUAD D F/F,+EDG TRG,SOIC	742619	89536 742619	1	1	
U 18	* IC,STTL,600 GATE ARY,9100A-99100,PLCC	741546	89536 741546	1	1	
U 19	* IC,STTL,600 GATE ARY,9100A-99101,PLCC	741553	89536 741553	1	1	
U 20, 23	* IC,BIPOLAR,8-BIT DAL,UP-COMPATIBLE	743112	89536 743112	2	1	
U 21, 22	* IC,LSTTL,8-BIT BINARY CNTR W/REG,SOIC	782243	89536 782243	2	1	
U 24, 37	* IC,COMPARATOR,QUAD,14 PIN,SOIC	741561	89536 741561	2	1	
U 25	* IC,LSTTL,QUAD BUS,SOIC	740977	89536 740977	1	1	
U 26, 32, 33	* IC,LSTTL, 4 BIT UP/DOWN CNTR,SOIC	742114	89536 742114	3	1	
U 27	* IC,LSTTL,DUAL D F/F,+EDG TRG,SOIC	740985	89536 740985	1	1	
U 28, 29	* IC,ECL,QUAD ECL-TTL TRANSLATOR	801274	89536 801274	2	1	
U 30	* IC,COMPRTR,DUAL,HI-SPEED,16 PIN DIP	782219	89536 782219	1	1	
U 31	* IC,FTTL,QUAD D F/F,+EDG TRG,SOIC	801399	89536 801399	1	1	
U 34	* IC,FTTL, 4 BIT UP/DOWN COUNTER	782235	89536 782235	1	1	
U 35, 36, 39	* IC,LSTTL,OCTL BUS TRNSCVR W/3-ST,SOIC	781195	89536 781195	3	1	
U 38	* IC,FTTL,DUAL 4 INPUT NAND GATE,SOIC	742155	89536 742155	1	1	
U 40	* IC,VOLT REG,FIXED,+5 VOLTS,0.1 AMPS	429910	07263 uA78L05AWC	1	1	
U 41	* IC,OP AMP,QUAD,LOW POWER,SOIC	742569	89536 742569	1	1	
XF 1	HLDR PART,FUSE,BODY,PWB MT	602763	89536 602763	1		

An * in 'S' column indicates a static-sensitive part.

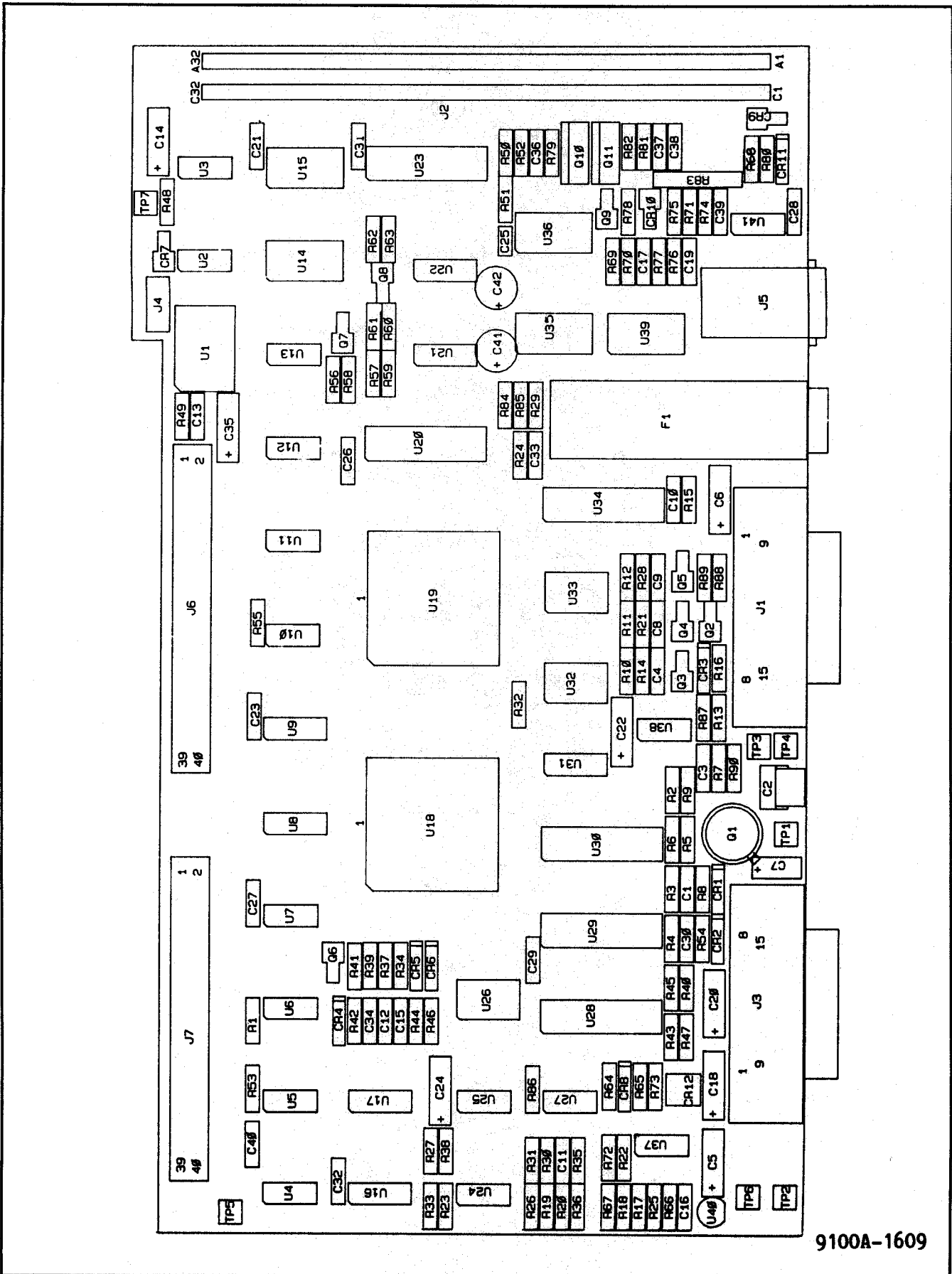

9100A-1609

Figure 5-9. A9 Probe I/O Interface PCA

5/List of Replaceable Parts

Table 5-11. A10 Multi-Function Interface PCA
(See Figure 5-10.)

REFERENCE DESIGNATOR	FLUKE STOCK	MFRS SPLY	MANUFACTURERS PART NUMBER	TOT QTY	R S	O T	N T
-A>-NUMERICS--> S	-----	NO--	OR GENERIC TYPE----				
	DESCRIPTION-----						
B 1	BATTERY, LITHIUM, 3.5V, 0.75AH	782953	89536 782953	1			
C 1, 2	CAP, CER, 15PF, +-2%, 100V, COG	369074	89536 369074	2			
C 3, 10- 21	CAP, CER, 0.01UF, +-20%, 100V, X7R	407361	72982 8121-A100-W5R-103M	13			
CR 1	* DIODE, SI, BV= 75.0V, IO=150MA, 500 MW	203323	07910 1N4448	1			1
H 1	SCREW, THD CUT, PHP, S. STL. 4-24X3/8	183574	89536 183574	2			
H 2	RIVET, POP, DOME, AL, 0.125X0.316	423616	89536 423616	2			
J 1	CONN, DIN41614, TYPE R, RT ANG, 96 SCRT	747816	89536 747816	1			
J 2	HEADER, 2 ROW, 0.100 CTR, RT ANG, 50 PIN	783464	89536 783464	1			
J 3	HEADER, 2 ROW, 0.100CTR, 50 PIN	782201	89536 782201	1			
MP 1	SCSI CONNECTOR BRACKET	768663	89536 768663	1			
Q 1	* TRANSISTOR, SI, PNP, SMALL SIGNAL	195974	64713 2N3906	1			1
Q 2	* TRANSISTOR, SI, NPN, SMALL SIGNAL	218396	04713 2N3904	1			1
R 1- 3, 6,	RES, CF, 10K, +-5%, 0.25W	348839	80031 CR251-4-5P10K	7			
R 7, 9, 12		348839					
R 4	RES, CC, 22M, +-5%, 0.25W	221986	01121 CB2265	1			
R 5	RES, CF, 51K, +-5%, 0.25W	376434	80031 CR251-4-5P51K	1			
R 8, 10	RES, CF, 200K, +-5%, 0.25W	441485	80031 CR251-4-5P200K	2			
RN 1, 2	RES, NET, SIP, 10PIN, 9RES, 220, +-2%	769356	89536 769356	2			
RN 3, 4	RES, NET, SIP, 10PIN, 9RES, 330, +-2%	769364	89536 769364	2			
RN 5	RES, NET, SIP, 10PIN, 9RES, 10K, +-2%	414003	80031 95081002CL	1			
TP 1- 3	TERM, UNINSUL, WIRE FORM, TEST POINT	781237	89536 781237	3			
U 2	* IC, NMOS, SMALL COMPTR SYS INT	742858	89536 742858	1			1
U 3	* IC, 20LS, PROGRAMMED LOGIC ARRAY	818211	89536 818211	1			1
U 9	* IC, CMOS, PARALLEL, I/O CALENDER & CLOCK	604181	12040 MM58167N	1			1
U 10	* IC, LSTTL, 8BIT S-IN, P-OUT R-SHIFT RGS	408732	01295 SN74LS164N	1			1
U 11	* IC, CMOS, HEX INVERTERS	799924	89536 799924	1			1
U 12	* IC, CMOS, QUAD 2-INPUT NAND GATE	741280	89536 741280	1			1
XU 2	SOCKET, IC, 40 PIN	429282	09922 DILB40P-108	1			
XU 3	SOCKET, IC, 24 PIN,	643999	89536 643999	1			
XU 9	SOCKET, IC, 24 PIN	376236	91506 324-AG39D	1			
Y 1	* CRYSTAL, 32.768KHZ, +-0.003%	501817	89536 501817	1			1

An * in 'S' column indicates a static-sensitive part.

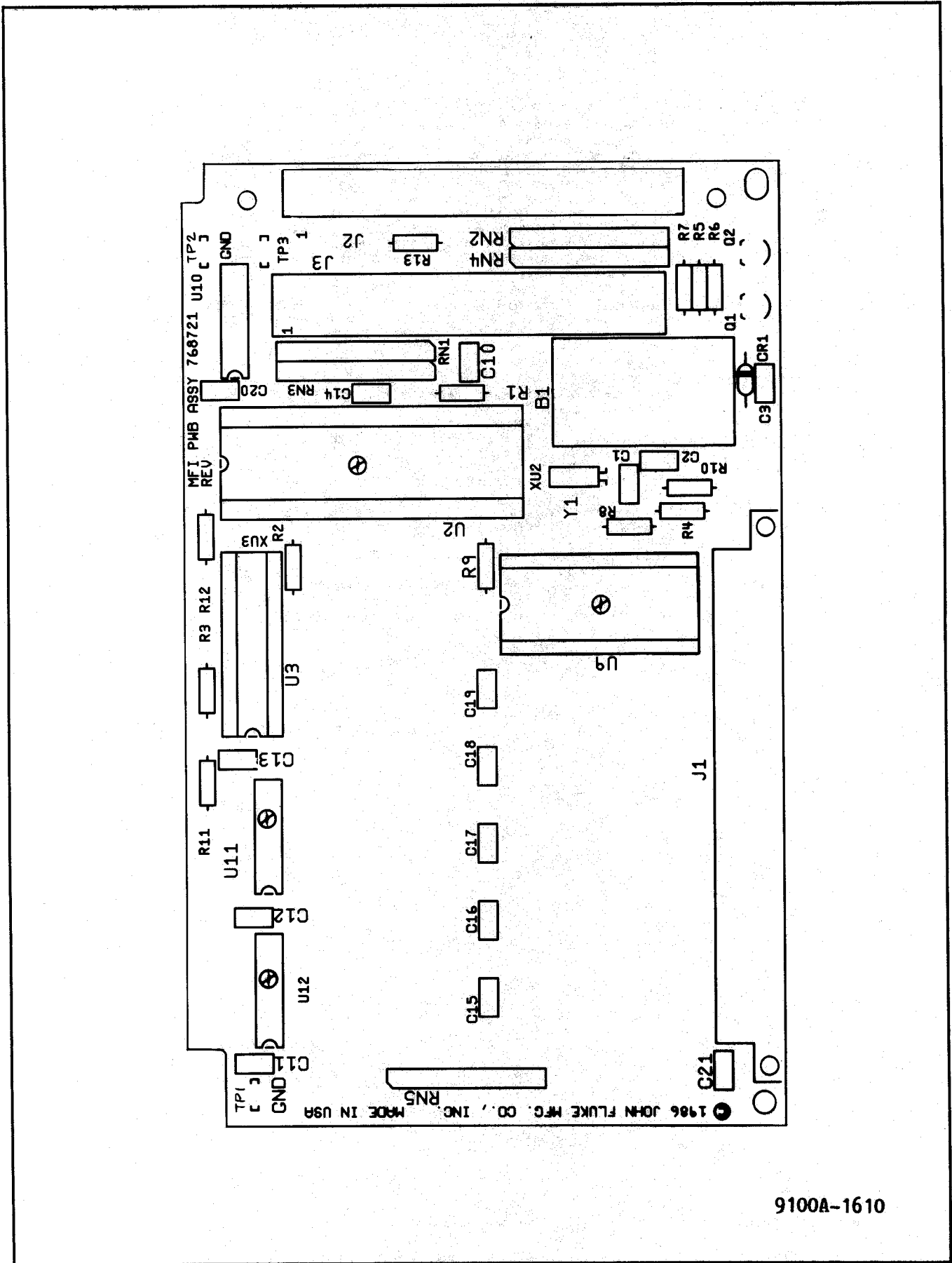

Figure 5-10. A10 Multi-Function Interface PCA

5/List of Replaceable Parts

Table 5-12. All I/O Connector PCA
(See Figure 5-11.)

REFERENCE DESIGNATOR	FLUKE STOCK	MFRS SPLY	MANUFACTURERS PART NUMBER	TOT	R	N
-A>-NUMERICS-->	NO	CODE	-OR GENERIC TYPE----	QTY-	-Q	-E-
C 1, 17	641217	57640	SM/VB	2		
C 2- 15	407361	72982	8121-A100-W5R-103M	14	1	
C 16	800045	89536	800045	1		
CR 1, 2	* 343491	01295	1N4002	2	1	
H 1	152140	89536	152140	2		
H 2	183574	89536	183574	2		
J 1	782102	89536	782102	1		
J 2- 5	782177	89536	782177	4		
MP 1	799965	89536	799965	1		
R 1	348839	80031	CR251-4-5P10K	1		
R 3	219360	89536	219360	1	1	
R 4	512228	89536	512228	1		
R 5	294884	89536	294884	1		
TP 1	781237	89536	781237	1		
U 1, 2	* 801266	89536	801266	2	1	
U 3	* 393280	01295	SN74LS20N	1	1	
U 4	* 585497	12040	LM338K	1	1	
Z 1, 3	769364	89536	769364	2		
Z 2	484063	80031	95081002CL	1		

An * in 'S' column indicates a static-sensitive part.

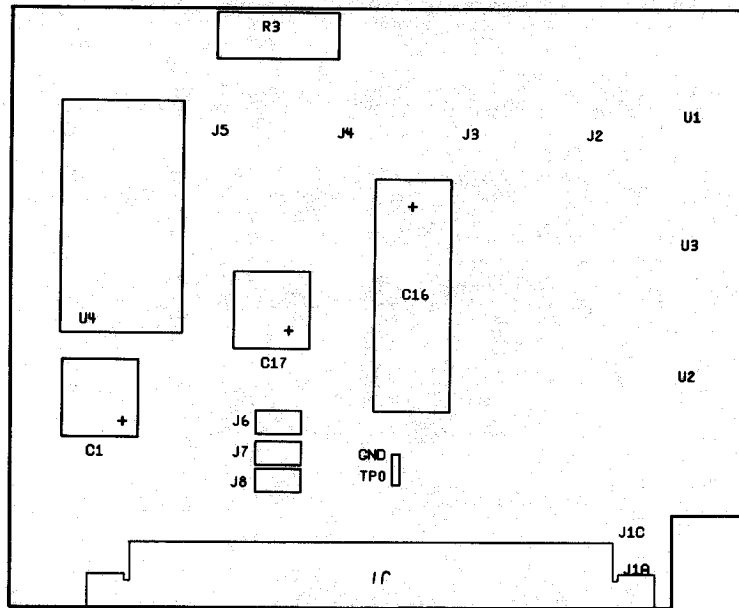

CKT 1 SIDE

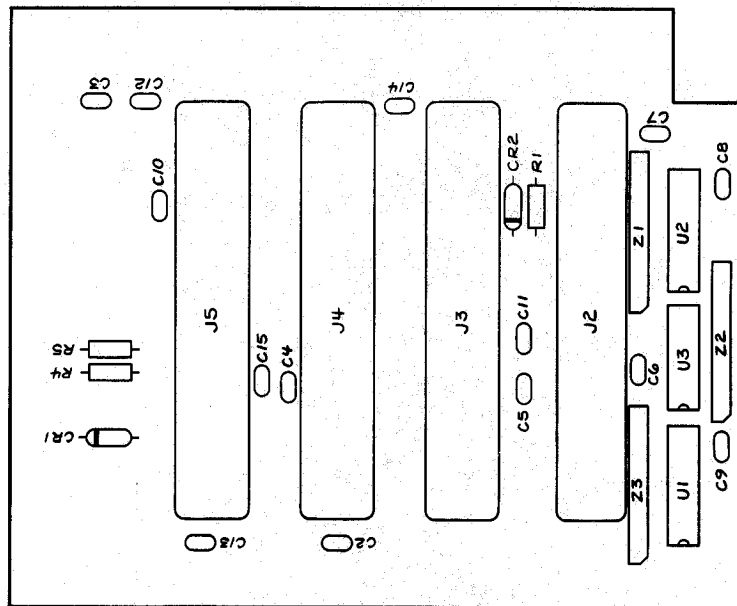

CKT 4 SIDE

9100A-1611

Figure 5-11. A11 I/O Connector PCA

5/List of Replaceable Parts

Table 5-13. A12 Half-Width Clip Modules

REFERENCE DESIGNATOR		DESCRIPTION	FLUKE STOCK NO	MFRS SPLY CODE	MANUFACTURERS PART NUMBER OR GENERIC TYPE	TOT QTY	R S T	N O E
C	1	CAP, CER, 0.1UF, +-20%, 50V, Z5U	597575	89536	597575	1		
C	2	CAP, CER, 0.01UF, +-20%, 100V, X7R	407361	72982	8121-A100-W5R-103M	1		
H	1	SCREW, MACH, PHP, STL, 4-40 X 5/8	800656	89536	800656	4		
J	1	CONN, RECT, PWB, PLUG, 33 POS	800680	89536	800680	1	1	
J	2, 3	CONNECTOR ASSY		89536		2		1
MP	1	CLIP, TEST, IC		89536		1	2	1
MP	2	CLIP, HOOK, W/0.025 PIN INTERFACE, BLACK	757500	89536	757500	1	2	
MP	3	BUTTON, SWITCH	773895	89536	773895	1		
MP	4	MODULE BOTTOM, SINGLE	768697	89536	768697	1		
MP	5	MODULE TOP, SINGLE	774034	89536	774034	1		
MP	6	KEY		89536		2		1
MP	7	MODULE DECAL		89536		1		1
P	1, 2	BANANA PLUG, PWB, SOLDER OR SWAGE TYPE	800698	89536	800698	2		
S	1	SWITCH, PUSHBUTTON, SPST, MOMENTARY	782433	89536	782433	1	1	
S	2	SWITCH, DIP, SPST, 4 POS	408559	00779	435166-2	1		
W	1	CABLE SET ASSY		89536		1		1
W	2	WIRE ASSY, GROUND CLIP	801704	89536	801704	1	1	

An * in 'S' column indicates a static-sensitive part.

NOTES:

1 - Refer to the table below for appropriate part numbers for each type of Clip Module:

	MODULE								
	-14D	-14S	-16D	-16S	-18D	-20D	-20S	-24D	-24S
MP1	800052	817429	800060	817437	800078	800086	817445	800094	817478
W1	801639	801639	801647	801647	801654	801662	801662	801670	801670
J2,3	801878	801878	801886	801886	801894	801902	801902	801910	801910
MP6	-	-	-	-	773952	773952	773952	767954	767954
MP7	802140	819631	802157	819649	802165	802173	819656	802181	819664

5/List of Replaceable Parts

Table 5-14. A13 Full-Width Clip Modules

REFERENCE DESIGNATOR	FLUKE STOCK	MFRS SPLY	MANUFACTURERS PART NUMBER	TOT QTY	R S T	N O E
-A>-NUMERICS--> S-----DESCRIPTION-----	--NO--	-CODE-	-OR GENERIC TYPE-----	QTY-	-Q-	-E-
C 1, 4	407361	72982	8121-A100-W5R-103M	2		
C 2, 3	597575	89536	597575	2		
H 1	800656	89536	800656	4		
J 1, 2	800680	89536	800680	2	1	
J 3, 4		89536		2		1
MP 1		89536		1	2	1
MP 2	757500	89536	757500	1	2	
MP 3	773895	89536	773895	1		
MP 4	802132	89536	802132	1		
MP 5	802124	89536	802124	1		
MP 6	767954	89536	767954	2		
MP 7		89536		1		1
P 1- 4	800698	89536	800698	2		
S 1	782433	89536	782433	1	1	
S 2	414490	00779	435166-5	1		
W 1		89536		1		1
W 2	801704	89536	801704	1	1	

An * in 'S' column indicates a static-sensitive part.

NOTES:

1 - Refer to the table below for appropriate part numbers for each type of Clip Module:

	MODULE		
	-28D	-28S	-40D
MP1	800102	821975	800110
W1	801688	801688	801696
J3,4	801928	801928	801936
MP7	802199	819672	802207

5/List of Replaceable Parts

Table 5-15. A14 Calibration Module

REFERENCE DESIGNATOR		FLUKE STOCK	MFRS SPLY	MANUFACTURERS PART NUMBER	TOT	R	N
-A>-NUMERICS----->	S-----	NO--	CODE-	-OR GENERIC TYPE-----	QTY-	-Q	-E-
H	1						
		800656	89536	800656	7		
J	1, 2						
		800680	89536	800680	2	1	
MP	2						
		801050	89536	801050	1	1	
MP	3						
		172080	89536	172080	2		
MP	4						
		773895	89536	773895	1		
MP	5						
		802132	89536	802132	1		
MP	6						
		802124	89536	802124	1		
MP	7						
		767954	89536	767954	2		
MP	8						
		802223	89536	802223	1		
P	1- 4						
		800698	89536	800698	2		
S	1						
		782433	89536	782433	1	1	

An * in 'S' column indicates a static-sensitive part.

5/List of Replaceable Parts

Table 5-16. A15 Flying Lead Module

REFERENCE DESIGNATOR	FLUKE STOCK	MFRS SPLY	MANUFACTURERS PART NUMBER	TOT	N R O
-A>-NUMERICS--> S	DESCRIPTION	NO	OR GENERIC TYPE	QTY	-Q -E-
C 1	CAP, CER, 0.1UF, +-20%, 50V, 25U	597575	89536 597575	1	
C 2	CAP, CER, 0.01UF, +-20%, 100V, X7R	407361	72982 8121-A100-W5R-103M	1	
H 1	SCREW, MACH, PHP, STL, 4-40 X 5/8	800656	89536 800656	4	
J 1	CONN, RECT, PWB, PLUG, 33 POS	800680	89536 800680	1	1
MP 1	BUTTON, SWITCH	773895	89536 773895	1	
MP 2	MODULE BOTTOM, SINGLE	768697	89536 768697	1	
MP 3	MODULE TOP, SINGLE	774034	89536 774034	1	
MP 4	KEY	773952	89536 773952	2	
MP 5	MODULE DECAL	802215	89536 802215	1	
MP 6	CLIP, HOOK	757500	89536 757500	25	10
P 1, 2	BANANA PLUG, PWB, SOLDER OR SWAGE TYPE	800698	89536 800698	2	
S 1	SWITCH, PUSHBUTTON, SPST, MOMENTARY	782433	89536 782433	1	1
S 2	SWITCH, DIP, SPST, 4 POS	408559	00779 435166-2	1	
W 1	CABLE ASSY, 10 PAIR, POS 1-10	801712	89536 801712	1	
W 2	CABLE ASSY, 10 PAIR, POS 1-10	801720	89536 801720	1	

An * in 'S' column indicates a static-sensitive part.

5/List of Replaceable Parts

Table 5-17. A16 512K RAM Module
(See Figure 5-12.)

REFERENCE DESIGNATOR	FLUKE STOCK	MFRS SPLY	MANUFACTURERS PART NUMBER	TOT QTY	R S	O T
-A>-NUMERICS--> S	DESCRIPTION	NO	CODE	OR GENERIC TYPE	Q	E
C 1- 22	CAP, CER, 0.1UF, +/-10%, 25V, X7R, 1206	747287	89536	747287	22	
C 23	CAP, CER, 47PF, +/-10%, 50V, COG, 1206	747352	89536	747352	1	
U 1- 9, 11-	* IC, NMOS, 256K X 1 DRAM, 120NSEC, PLC	808212	89536	808212	18	1
U 19	*	808212				
U 10	* IC, ALSTTL, OCTAL BUS TRANSCEIVER, SOIC	799593	89536	799593	1	1
U 20	* IC, ALSTTL, QUAD 2 INPUT NAND GATE, SOIC	782268	89536	782268	1	1
U 21	* IC, ALSTTL, QUAD 2 INPUT OR GATE, SOIC	742460	89536	742460	1	1
U 22	* IC, ALSTTL, DUAL JK F/F, -EDG TRG, SOIC	807578	89536	807578	1	1

An * in 'S' column indicates a static-sensitive part.

NOTE

The 9105A-007 uses two A16 512K RAM Modules.

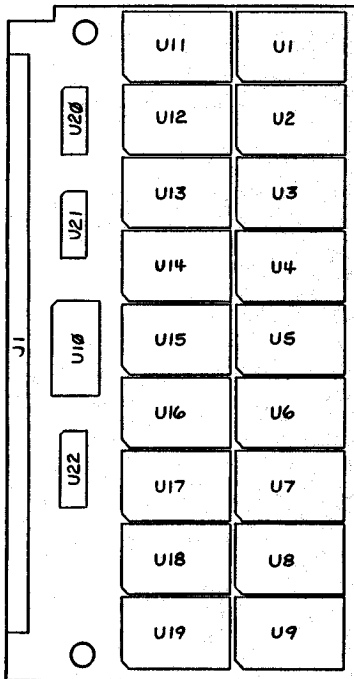

CKT 4

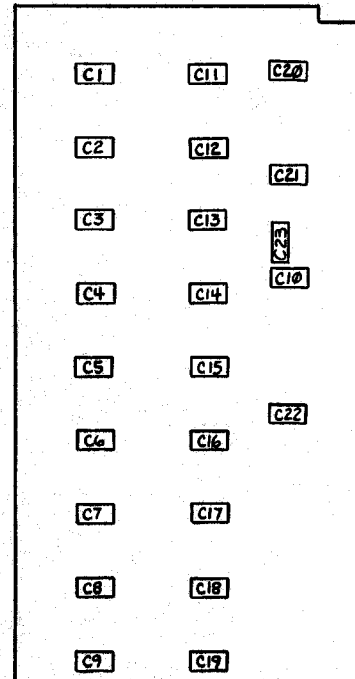

CKT 1

9100A-1616

Figure 5-12. A16 512K RAM Module

5/List of Replaceable Parts

Table 5-18. A19 Monochrome Monitor

REFERENCE DESIGNATOR	FLUKE STOCK	MFRS SPLY	MANUFACTURERS PART NUMBER	TOT	R	O	N
-A>-NUMERICS--> S	NO	CODE	OR GENERIC TYPE	QTY	Q	S	T
BT 1	POWER SUP, 40W, +5@3.5A, +12@2A, -12@1A	769406	89536 769406	1			
H 1	SCREW, MACH, PH, P, STL, 10-32X0.375	114314	73734 19084	4			
H 2	WASHER, FLAT, STEEL, 0.203X0.434X0.031	110262	89536 110262	3			
H 3	WASHER, FLAT, STL, .149, .375, .031	110270	89536 110270	8			
H 4	SCREW, MACH, PH, P, STL, 6-32X0.375	152165	89536 152165	8			
H 5	SCREW, MACH, SEMS, PH, P, STL, 6-32X0.375	177022	89536 177022	3			
H 6	SCREW, MACH, SEMS, PH, P, STL, 6-32X0.375	177022	89536 177022	5			
H 7	SCREW, MACH, PHP SEMS, STL, 4-40X1/4	185918	89536 185918	6			
H 8	CONN ACC, D-SUB, LATCH BLOCK, SHORT, 4-40	783480	89536 783480	2			
H 9	SCREW, MACH, PH, P, STL, 6-32X1.000	114215	89536 114215	3			
H 10	WASHER, FLAT, STL, .149, .375, .031	110270	89536 110270	3			
H 11	SCREW, MACH, SEMS, PH, P, STL, 6-32X0.375	177022	89536 177022	4			
MP 1	BRACKET, CRT, FINISHED	794149	89536 794149	4	1		
MP 2	LABEL, BAR-CODE, 9.4 CPI, 0.245X1.25	807099	89536 807099	2			
MP 3	CHASSIS, FINISHED	794156	89536 794156	1			
MP 4	SPACER, PWB, NYL, .312	780619	89536 780619	3			
MP 5	BEZEL ASSY, 9100	792903	89536 792903	1			
MP 6	GASKET, TOUCH PANEL, DUST	843250	89536 843250	1			
MP 7	NAMEPLATE	787275	89536 787275	1			
MP 8	COVER, CHASSIS, 9100, FINISHED	794198	89536 794198	1			
MP 9	DAMPER, VIBRATION	805085	89536 805085	4			
MP 10	CABLE TIE ANCHOR, ADHSV, 0.160" TIE	407908	89536 407908	5			
MP 11	CABLE TIE, 4"L, 0.100"W, 0.75 DIA	172080	89536 172080	8			
MP 12	DECAL, COVER, 9100	792911	89536 792911	1			
MP 13	DECAL, FAN PANEL	785493	89536 785493	1			
MP 14	BRACKET, POT MOUNTING, FINISHED	794131	89536 794131	1			
MP 15	THUMBWHEEL, POTENTIOMETER	787358	89536 787358	1			
MP 16	SHIPPING BOX	776435	89536 776435	1			
MP 17	SHIPPING INSERT	777045	89536 777045	1			
MP 18	OPTION TRAY	801613	89536 801613	1			
MP 19	SHIPPING CARRIER/INSERT	777052	89536 777052	1			
MP 20	INSERT, OPTION TRAY	809616	89536 809616	1			
MP 21	ENCLOSURE W/GRILLS	802454	89536 802454	1			
MP 22	COVER, FAN	787366	89536 787366	1			
MP 23	DECAL, CAUTION	787242	89536 787242	1			
MP 24	BASE	747972	89536 747972	1			
MP 25	RETAINER, NUT	749655	89536 749655	1			
MP 26	BUSHING COVER RF OUTPUT	802553	89536 802553	1			
MP 27	SHOULDER WASHER	792861	89536 792861	2			
MP 28	RETAINER PIN	802520	89536 802520	1			
MP 29	BASE, MOUNTING PLATE	747998	89536 747998	1			
MP 30	FOOT, RUBBER, SELF-ADHESIVE, BLACK	513820	89536 513820	4			
MP 31	PIN, MECHANICAL, CLEVIS, 5/16 X 1-3/4	800524	89536 800524	1			
MP 32	SPRING, COIL, COMP, SQUARED END, M WIRE	800532	89536 800532	1			
MP 33	BUMPER, STEM, BUNA-S, 0.500X0.125	800839	89536 800839	4			
MP 34	ASSY, AC POWER PANEL	776377	89536 776377	1			
MP 35	DISPLAY, MONITOR GREEN	785444	89536 785444	1			
MP 36	CONTRAST OVERLAY	819987	89536 819987	0	1	1	
W 1	CORD, LINE, 5-15/IEC, 3-18AWG, SVT	284174	89536 284174	1			
W 2	CABLE ASSY, 9100	778613	89536 778613	1			

An * in 'S' column indicates a static-sensitive part.

NOTE 1 - Contrast overlay is part of the bezel assembly.

5/List of Replaceable Parts

Table 5-19. Option -003 Parallel I/O Module
(See Figure 5-13.)

REFERENCE DESIGNATOR	FLUKE STOCK	MFRS SPLY	MANUFACTURERS PART NUMBER	TOT QTY	R S T	N O T
-A>-NUMERICS-->	NO--	-CODE-	-OR GENERIC TYPE----		-Q-	-E-
A 7	* I/O MODULE (MAIN) PCA	768838	89536 768838	1		
A 8	* I/O MODULE (TOP) PCA	755611	89536 755611	1		
A 14	CALIBRATION MODULE	813980	89536 813980	1		
A 15	FLYING LEAD MODULE, 20 LEAD SET, TSTD	819763	89536 819763	1		
F 1	FUSE, 1/4 X 1-1/4, SLOW, 1.0A, 250V	109272	71400 MDL1A	1	5	
F 1	FUSE, 5X20MM, SLOW, 1A, 250V	808055	89536 808055	1	5	
H 1	SCREW, MACH, PHP, STL, 6-32 X 7/8	801241	89536 801241	4		
H 2	SCREW, MACH, PHP SEMS, STL, 6-32X1/4	178533	89536 178533	9		
MP 1	HLDR PART, FUSE, CAP, 1/4X1-1/4	460238	61935 031.1666	1		
MP 2	HLDR PART, FUSE, CAP, 5X20MM	461020	89536 461020	1		
MP 3	CASE TOP, I/O MODULE	773291	89536 773291	1		
MP 4	CASE BOTTOM, I/O MODULE	773283	89536 773283	1		
MP 5	DECAL, CASE TOP, I/O MODULE	805630	89536 805630	1		
MP 6	DECAL, CASE BOTTOM, I/O MODULE	773382	89536 773382	1		
MP 7	SHIELD, I/O MODULE	775866	89536 775866	1		
MP 8	FOOT, NON-SKID	774000	89536 774000	4		
MP 9	NAMEPLATE, SERIAL -REAR PANEL-	472795	89536 472795	1		
MP 10	CARTON KEYBOARD, I/O	805804	89536 805804	1		
MP 11	FOAM INSERT, KEYBOARD-I/O	805812	89536 805812	1		
MP 12	CONVOLUTED FOAM, KEYBOARD-I/O	805820	89536 805820	1		
W 1	CABLE ASSEMBLY, EXTERNAL EVENT	773945	89536 773945	1	1	
W 2	CABLE ASSY, I/O MODULE	783977	89536 783977	1		
W 3	WIRE, SHIELD CONTACT	803122	89536 803122	1		

An * in 'S' column indicates a static-sensitive part.

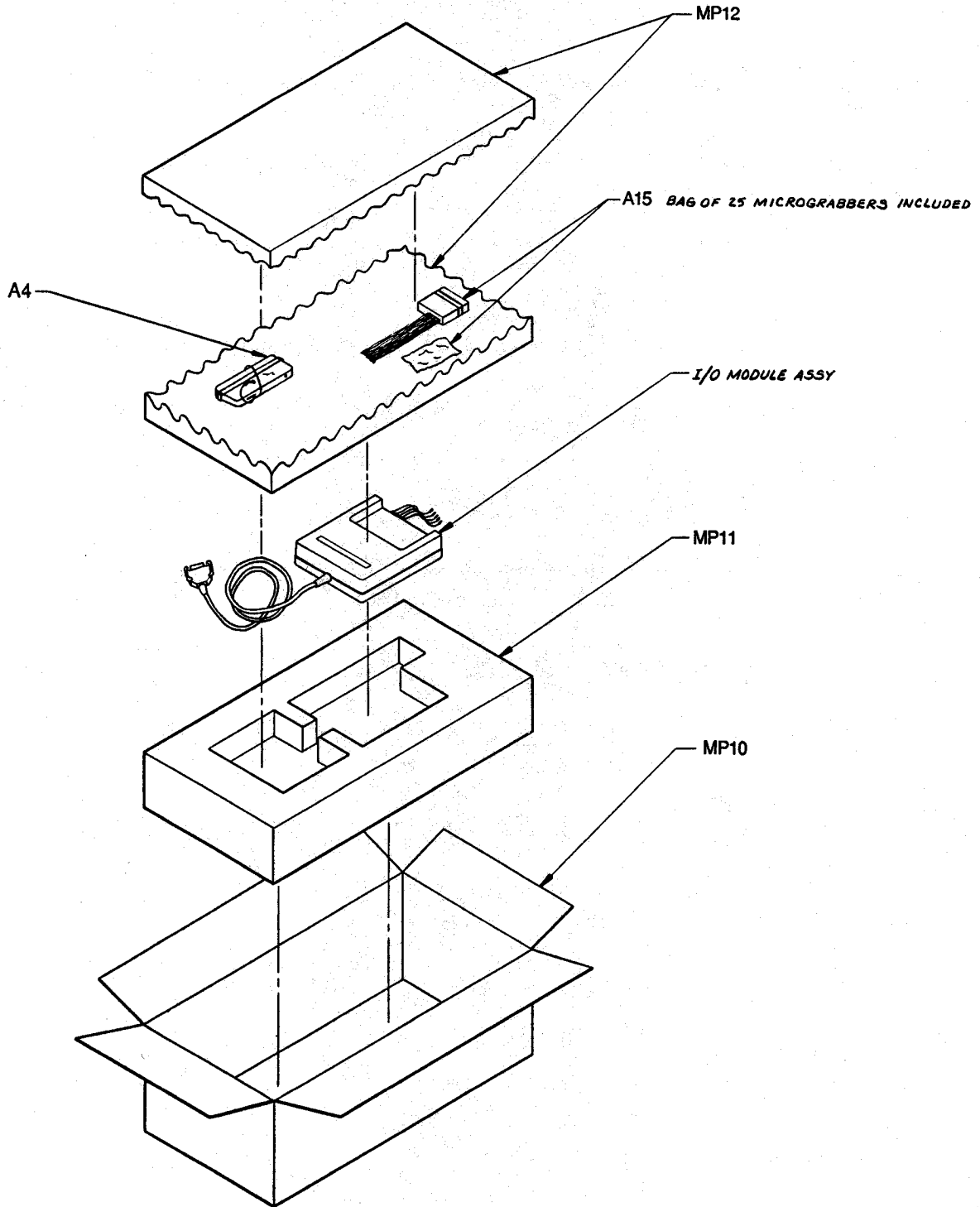

9100A-003
(1 of 3)

Figure 5-13. Option -003 Parallel I/O Module

5/List of Replaceable Parts

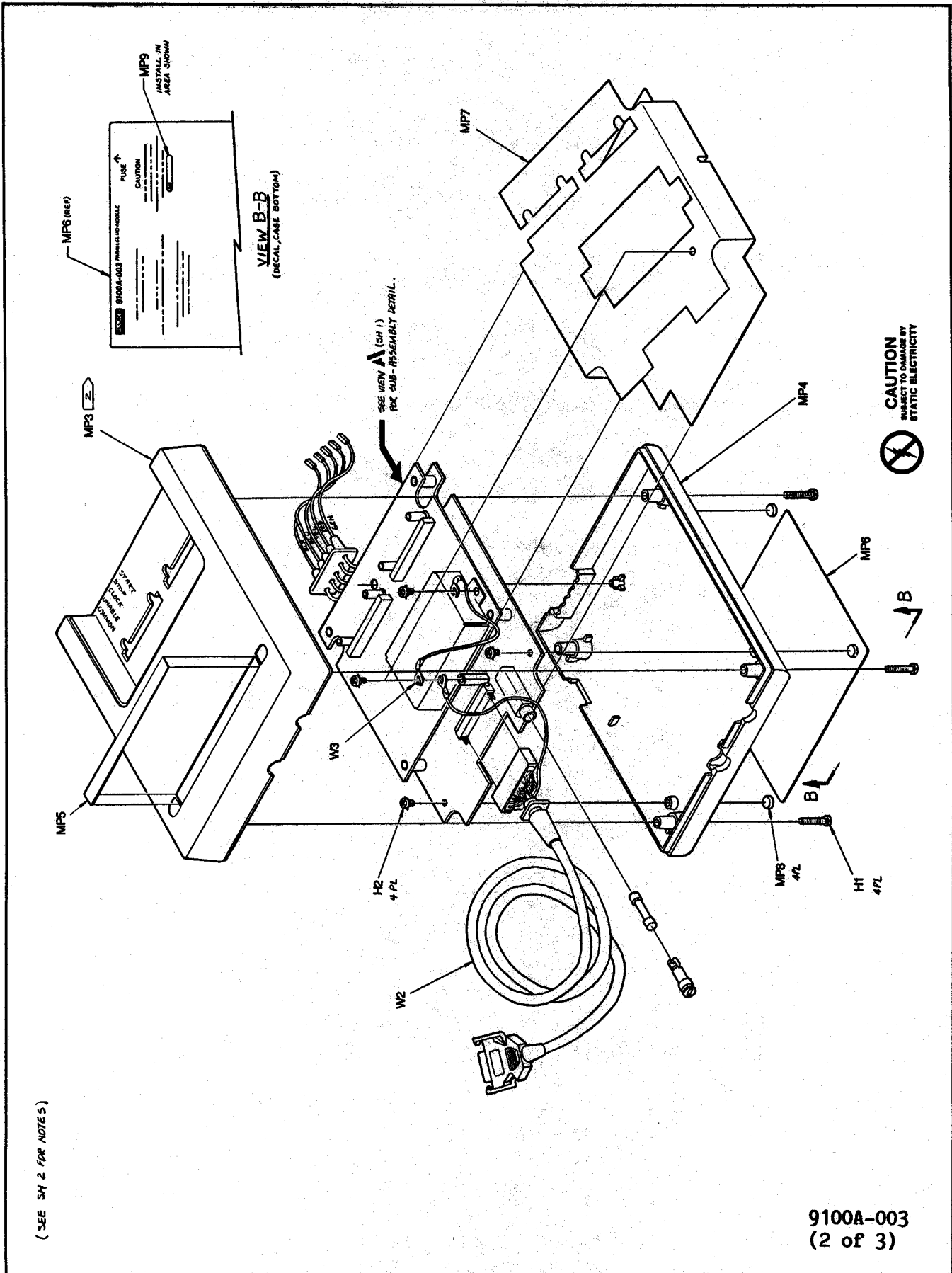
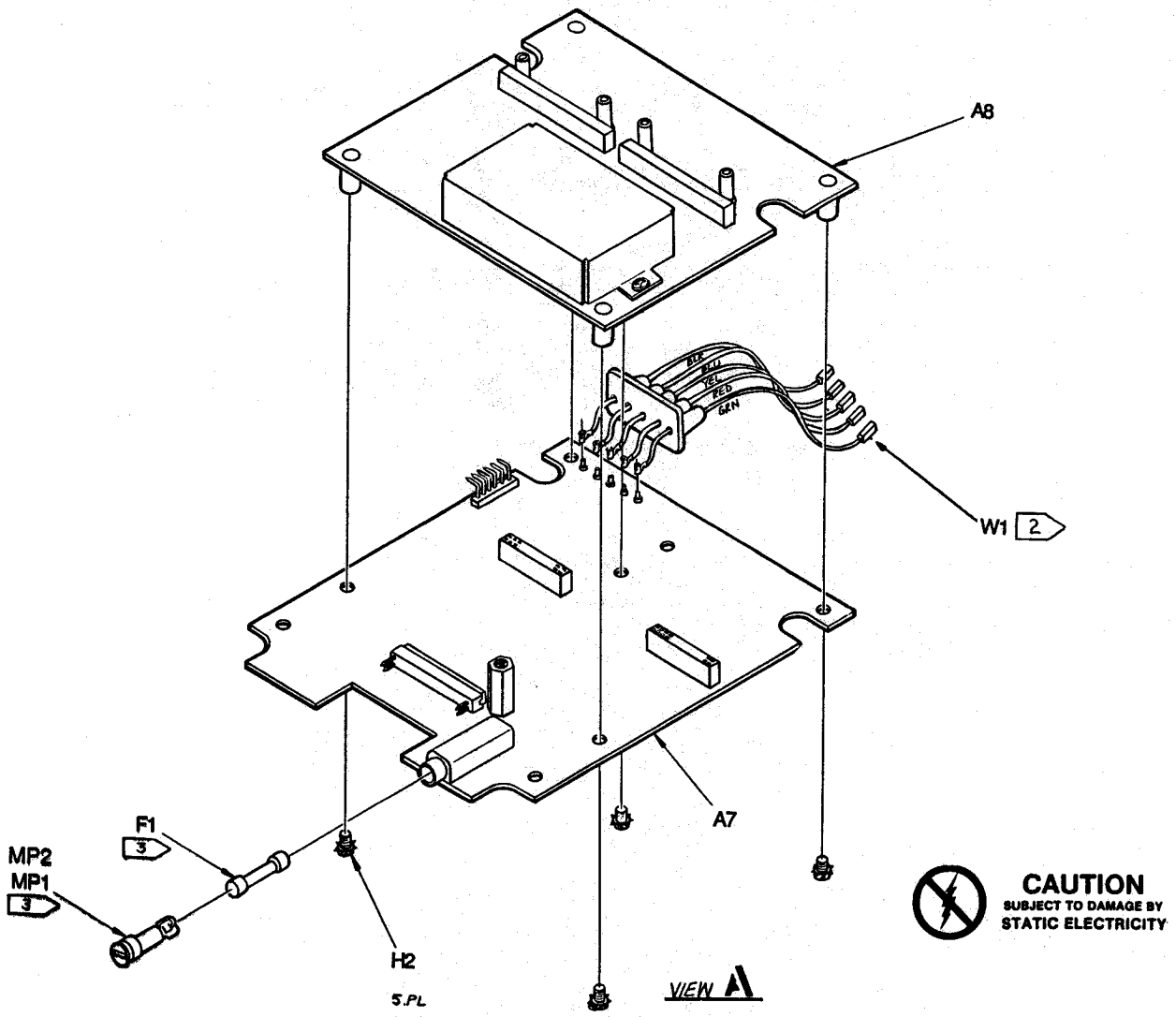

Figure 5-13. Option -003 Parallel I/O Module (cont.)



NOTES: UNLESS OTHERWISE SPECIFIED.

1. **WARNING:** Ⓢ INDICATES USAGE OF MOS DEVICE(S) WHICH MAY BE DAMAGED BY STATIC DISCHARGE. USE SPECIAL HANDLING PER S.O.P. 18.1

2. CABLE NOMENCLATURE ON MP3 CASE TOP SHALL MATCH UP WITH COLORS OF W1 AS NOTED:
 COMMON - BLACK WIRE
 UNABLE - BLUE WIRE
 CLOCK - YELLOW WIRE
 STOP - RED WIRE
 START - GREEN WIRE

3. FUSE & FUSE CAP VARY FOR DIFFERENT VOLTAGE CONFIGURATIONS: SEE FUSE CHART FOR FUSE & CAP PART NO.S.

FUSE CHART 3			CONFIGURATION
VOLTAGE	FUSE	CAP	
100/120V	109272	460238	115V 763649
220/240V	808055	461020	230V 763656

9100A-003
(3 of 3)

Figure 5-13. Option -003 Parallel I/O Module (cont.)

5/List of Replaceable Parts

Table 5-20. Option -004 Programmer's Station, Monochrome
(See Figure 5-14.)

REFERENCE DESIGNATOR	FLUKE STOCK	MFRS SPLY	MANUFACTURERS PART NUMBER	TOT QTY	R O S T
-A>-NUMERICS--> S	NO	CODE	-OR GENERIC TYPE	-Q	-E-
A 4	* 768762	89536	768762	1	
A 19	826362	89536	826362	1	
A 103	757120	89536	757120	1	1
H 1	423616	89536	423616	2	
MP 2	768648	89536	768648	1	
MP 3	472795	89536	472795	1	
MP 4		89536		1	2
MP 5	805804	89536	805804	1	
MP 6	805820	89536	805820	1	
MP 7	847066	89536	847066	1	
TM 1	818047	89536	818047	1	
TM 2	813857	89536	813857	1	
U 5	* 818195	89536	818195	1	
W 1	787903	89536	787903	1	
Z 1	783183	89536	783183	1	

An * in 'S' column indicates a static-sensitive part.

NOTES:

- 1 - See 9100A-013 option for replacement parts breakdown for A103.
- 2 - This software available only for 9100A's with Programmer's Station installed. Contact the factory if replacement is needed.

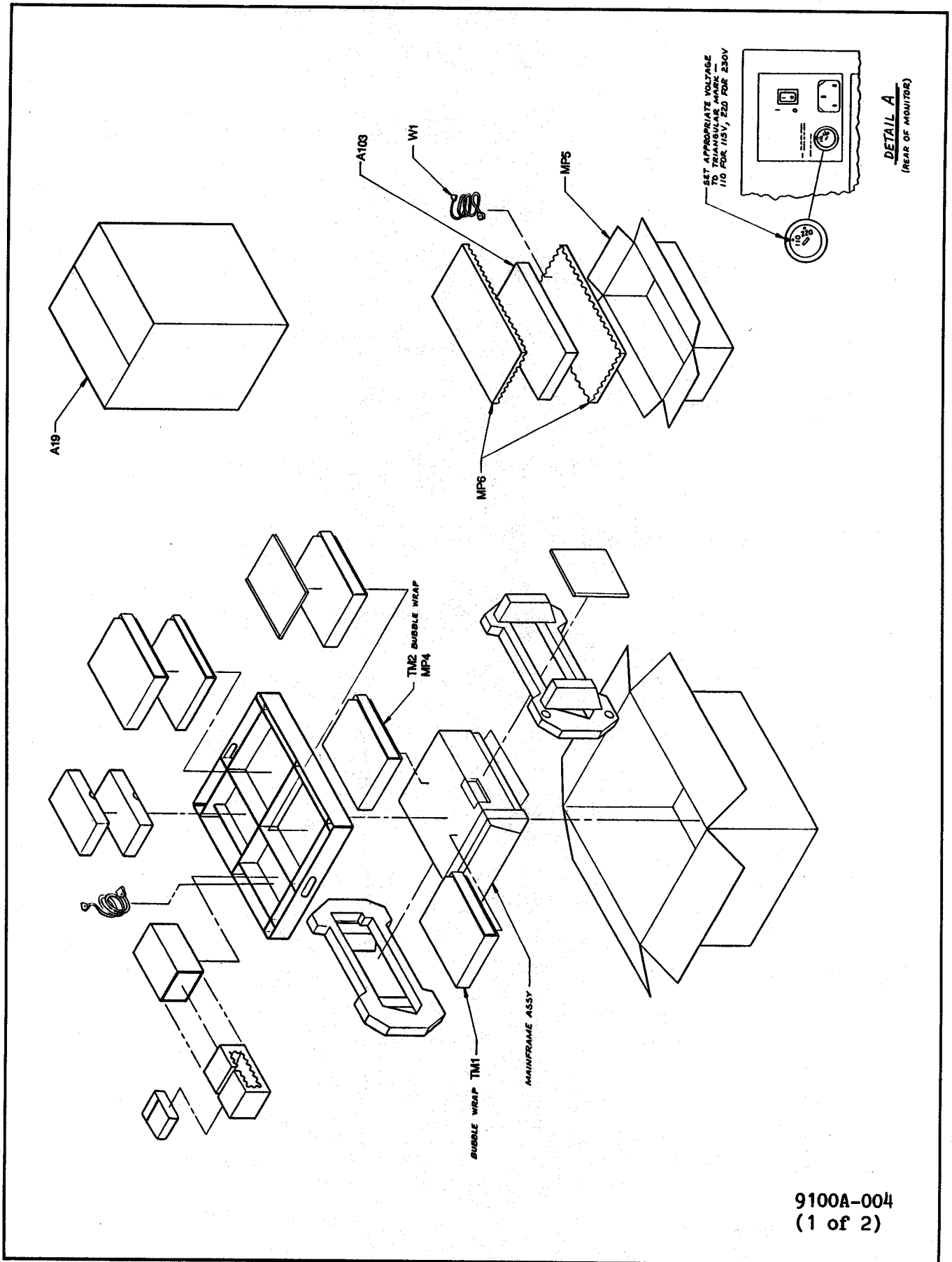

Figure 5-14. Option -004 Programmer's Station, Mono

5/List of Replaceable Parts

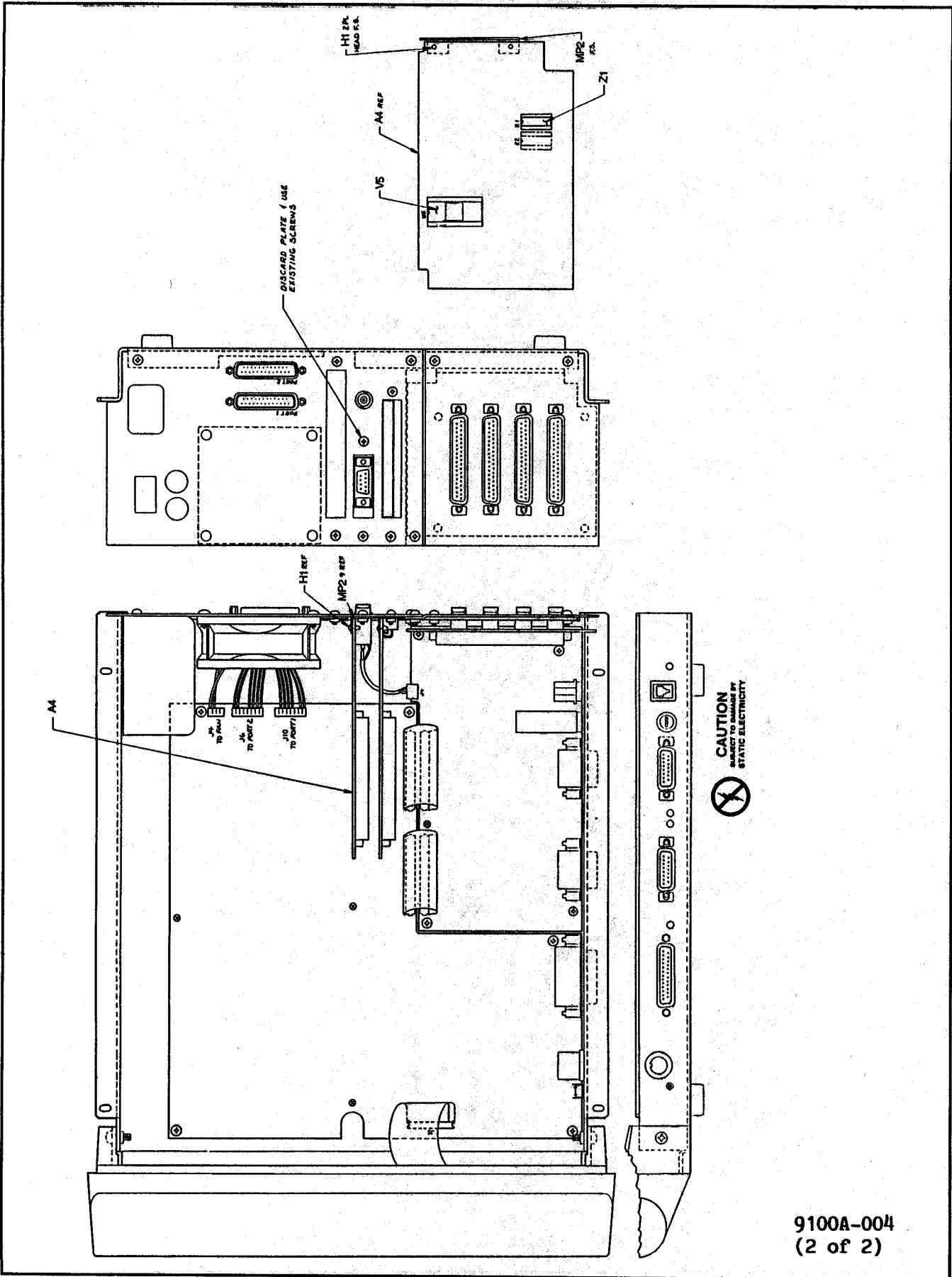

Figure 5-14. Option -004 Programmer's Station, Mono (cont.)

5/List of Replaceable Parts

Table 5-21. Option -005 Programmer's Station, Color
(See Figure 5-15.)

REFERENCE DESIGNATOR	FLUKE STOCK	MFRS SPLY	MANUFACTURERS PART NUMBER	TOT QTY	R O S T
-A>-NUMERICS--> S	--NO--	-CODE-	-OR GENERIC TYPE----		-Q -E-
A 4	* VIDEO CONTROLLER PCA	768762	89536 768762	1	
A 103	KEYBOARD, ASYNC ASCII, 1200 BAUD	757120	89536 757120	1	1
H 1	RIVET, POP, DOME, STL, 0.250X0.720	187625	89536 187625	2	
MP 2	VIDEO CONNECTOR BRACKET	768648	89536 768648	1	
MP 3	PROGRAMMER SOFTWARE SYSTEM, SLEEVED		89536	1	2
MP 4	CARTON KEYBOARD, I/O	805804	89536 805804	1	
MP 5	CONVOLUTED FOAM, KEYBOARD-I/O	805820	89536 805820	1	
MP 6	PROGRAM COPY PROTECTION SHEET	847066	89536 847066	1	
TM 1	9100A TL/1 REFERENCE MANUAL	818047	89536 818047	1	
TM 2	9100A PROGRAMMERS MANUAL	813857	89536 813857	1	
U 5	* PROGRAMMED 27128-150	818195	89536 818195	1	
Z 2	JUMPER, DIP, 0.300CTR, PROGRAM, 16 POS	783183	89536 783183	1	

An * in 'S' column indicates a static-sensitive part.

NOTES:

1 = See 9100A-013 option for replacement parts breakdown for A103.

2 = This software available only for 9100A's with Programmer's Station installed. Contact the factory if replacement is needed.

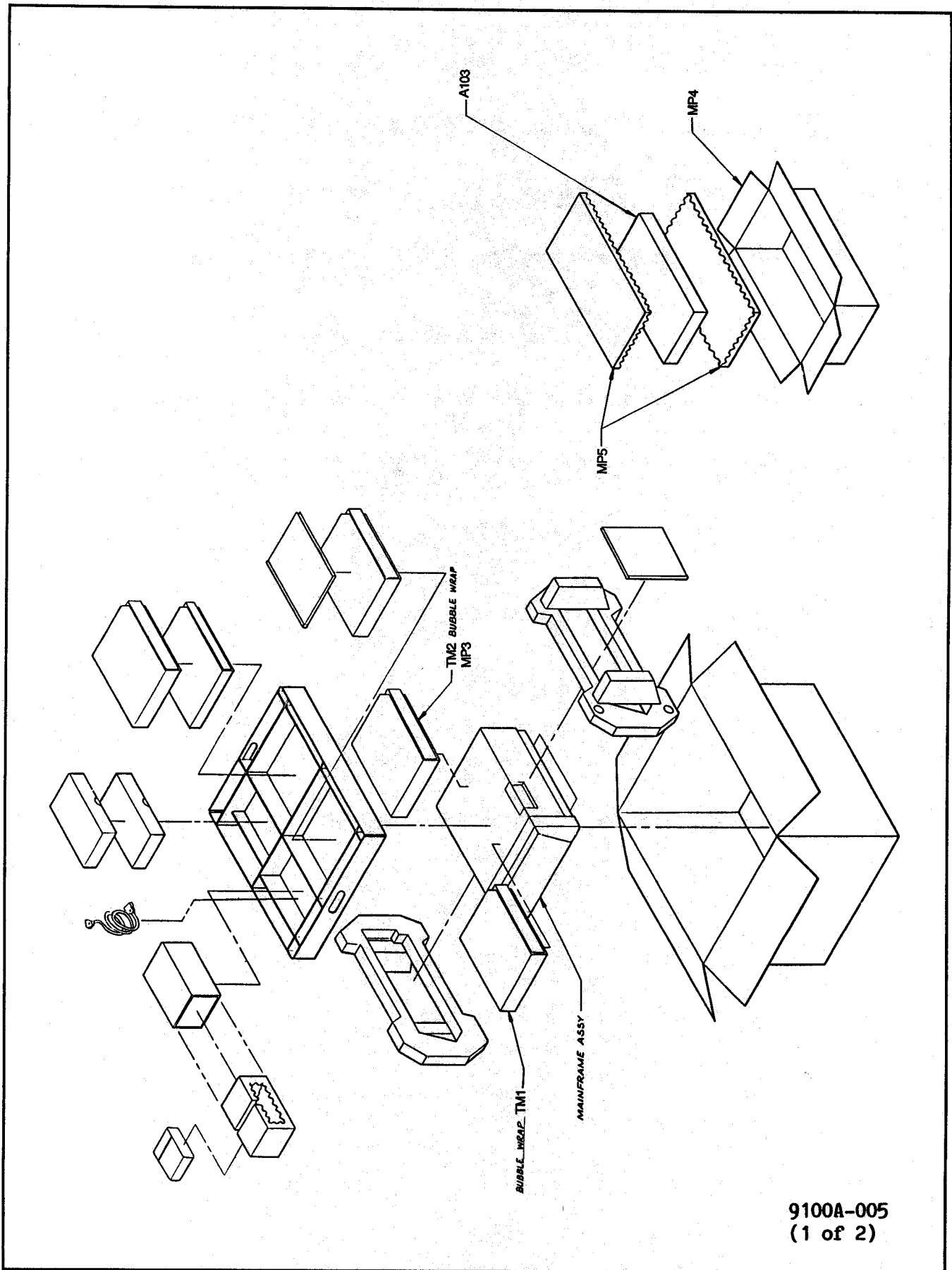

9100A-005
(1 of 2)

Figure 5-15. Option -005 Programmer's Station, Color

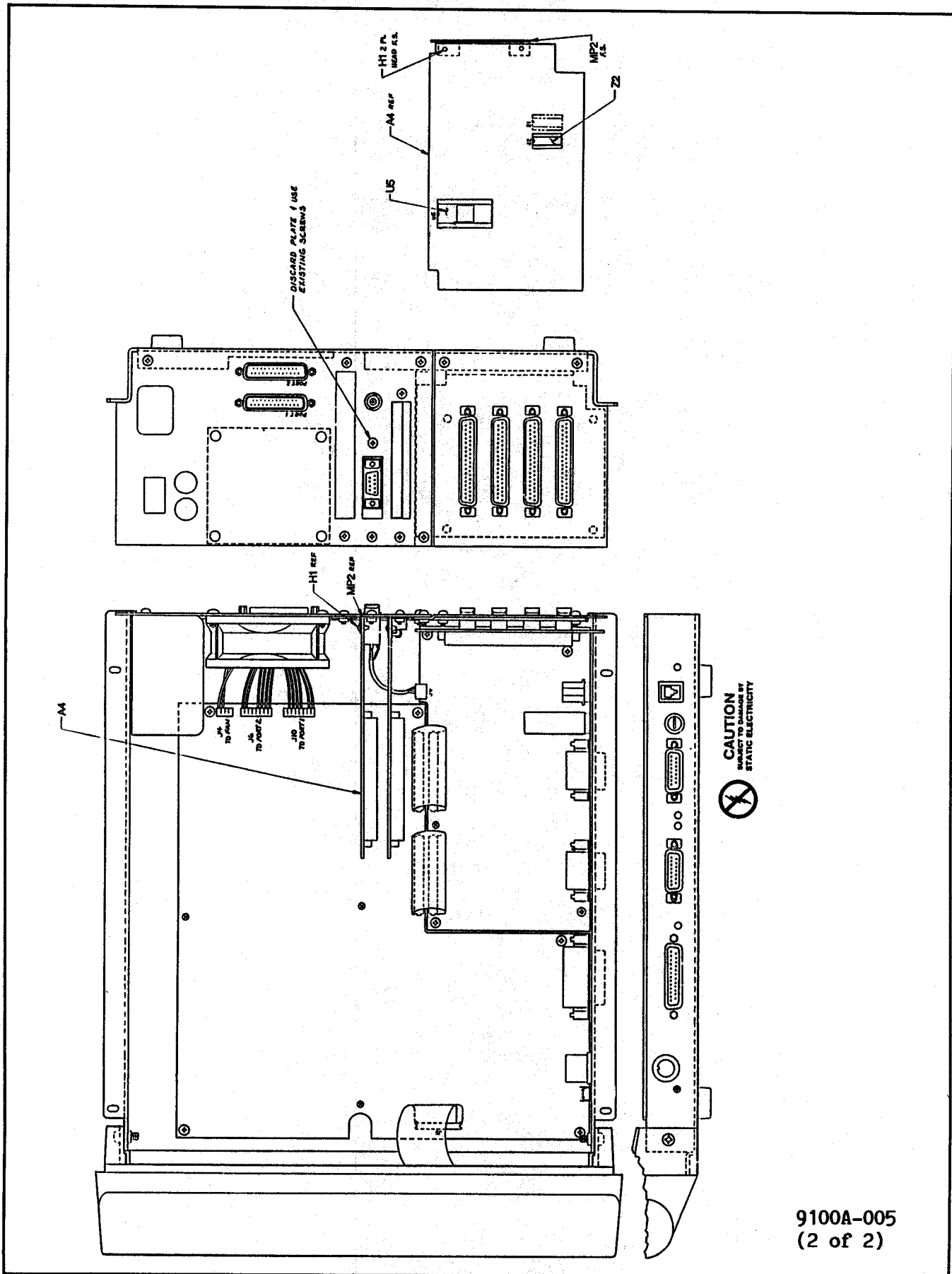

9100A-005
(2 of 2)

Figure 5-15. Option -005 Programmer's Station, Color (cont.)

5/List of Replaceable Parts

Table 5-22. Option -008 Real Time Clock PCA
(See Figure 5-16.)

REFERENCE DESIGNATOR	FLUKE STOCK	MFRS SPLY	MANUFACTURERS PART NUMBER	TOT QTY	R S T	N O T
-A>-NUMERICS-----	S-----DESCRIPTION-----	--NO--	-CODE-	-OR GENERIC TYPE-----	QTY-	-Q -E-
B 1		782953	89536	782953	1	1
C 1, 2		369074	89536	369074	2	1
C 3, 10- 21		407361	72982	8121-A100-W5R-103M	13	
CR 1	*	203323	07910	1N4448	1	1
H 1		183574	89536	183574	2	
H 2		423616	89536	423616	2	
J 1		747816	89536	747816	1	
MP 1		802009	89536	802009	1	
Q 1	*	195974	64713	2N3906	1	1
Q 2	*	218396	04713	2N3904	1	1
R 1, 2, 6,		348839	80031	CR251-4-5P10K	6	
R 7, 9, 12		348839				
R 4		221986	01121	CB2265	1	
R 5		376434	80031	CR251-4-5P51K	1	
R 8, 10		441485	80031	CR251-4-5P200K	2	
R 11		340075	80031	CR251-4-5P10E	1	
RN 5		414003	80031	95081002CL	1	
TP 1- 3		781237	89536	781237	3	
U 3	*	818211	89536	818211	1	1
U 9	*	604181	12040	MM58167N	1	1
U 10	*	408732	01295	SN74LS164N	1	1
U 11	*	799924	89536	799924	1	1
U 12	*	741280	89536	741280	1	1
XU 3		643999	89536	643999	1	
XU 9		376236	91506	324-AG39D	1	
Y 1	*	501817	89536	501817	1	1

An * in 'S' column indicates a static-sensitive part.

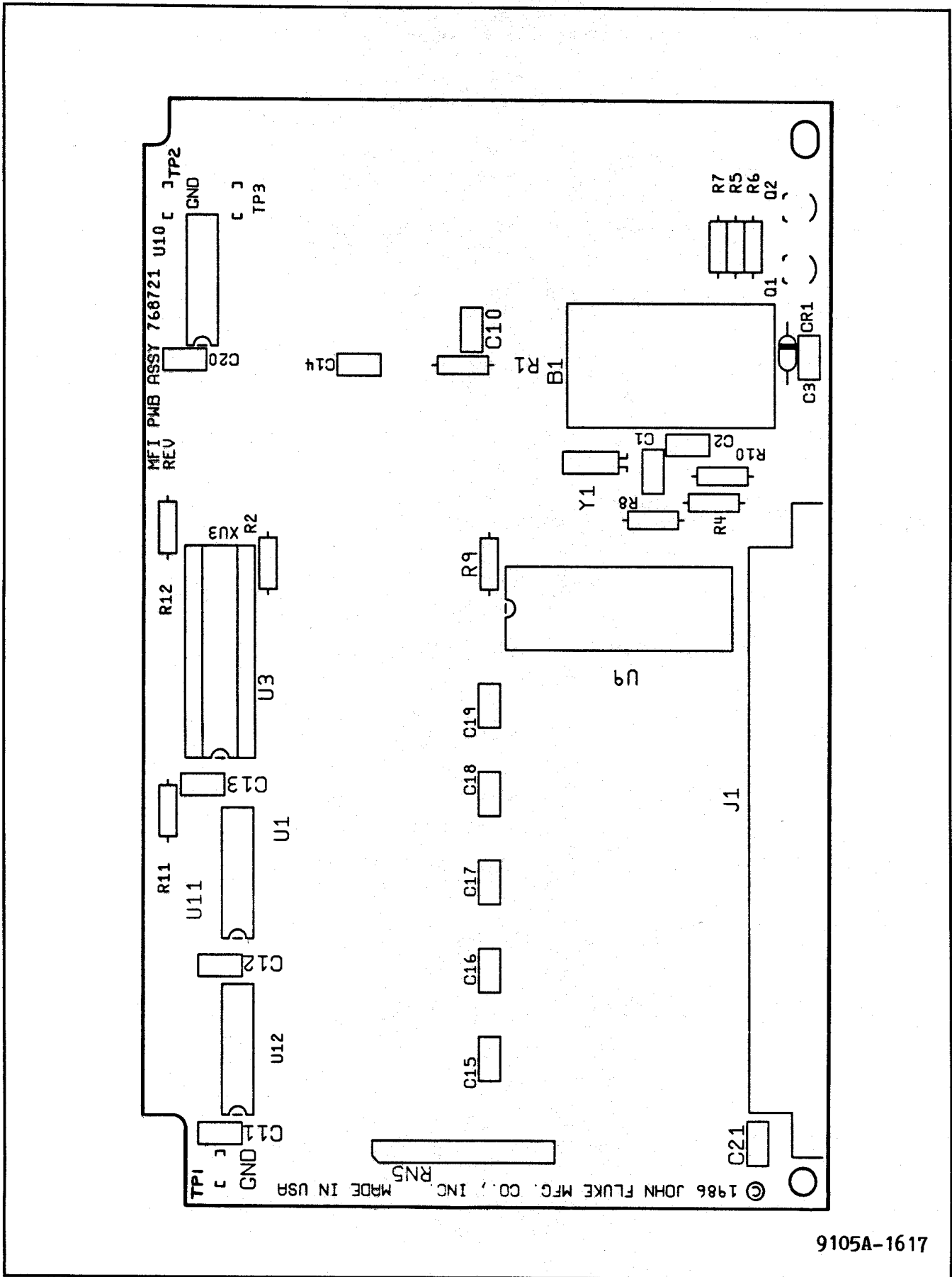

9105A-1617

Figure 5-16. Option -008 Real-Time Clock PCA

5/List of Replaceable Parts

Table 5-23. Option -009 Video, Monochrome
(See Figure 5-17.)

REFERENCE DESIGNATOR		DESCRIPTION	FLUKE STOCK	MFRS SPLY CODE	MANUFACTURERS PART NUMBER OR GENERIC TYPE	TOT QTY	R S	O T	N E
A	4	* VIDEO CONTROLLER PCA	768762	89536	768762	1			
A	19	MONOCHROME MONITOR	826362	89536	826362	1			
H	1	RIVET, POP, DOME, AL, 0.125X0.316	423616	89536	423616	2			
MP	2	VIDEO CONNECTOR BRACKET	768648	89536	768648	1			
MP	3	NAMEPLATE, SERIAL -REAR PANEL-	472795	89536	472795	1			
U	5	* PROGRAMMED 27128-150	818195	89536	818195	1			
W	1	CABLE, MONITOR	787903	89536	787903	1			
Z	1	JUMPER, DIP, 0.300CTR, PROGRAM, 16 POS	783183	89536	783183	1			

An * in 'S' column indicates a static-sensitive part.

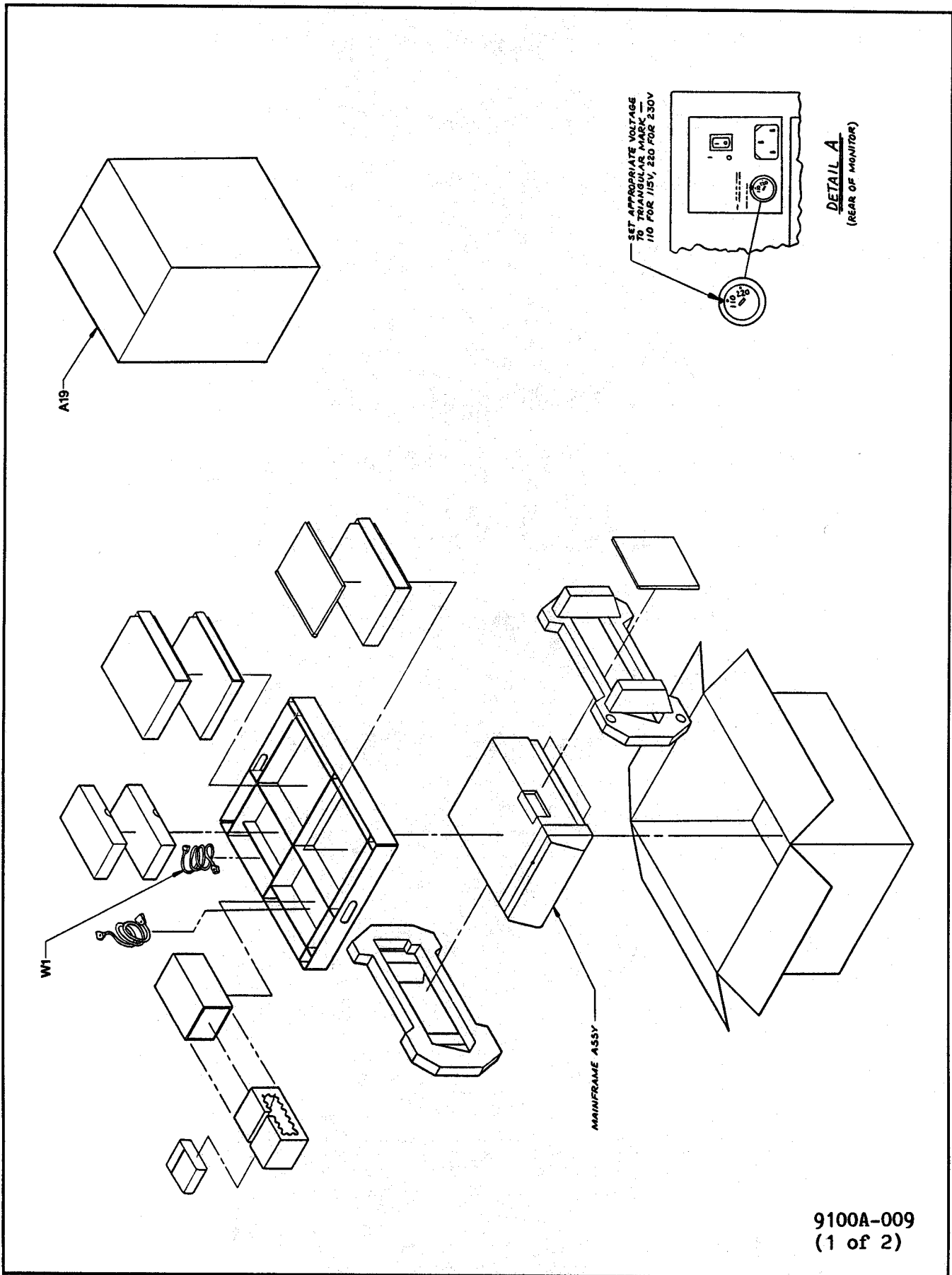

9100A-009
(1 of 2)

Figure 5-17. Option -009 Video, Monochrome
5-59

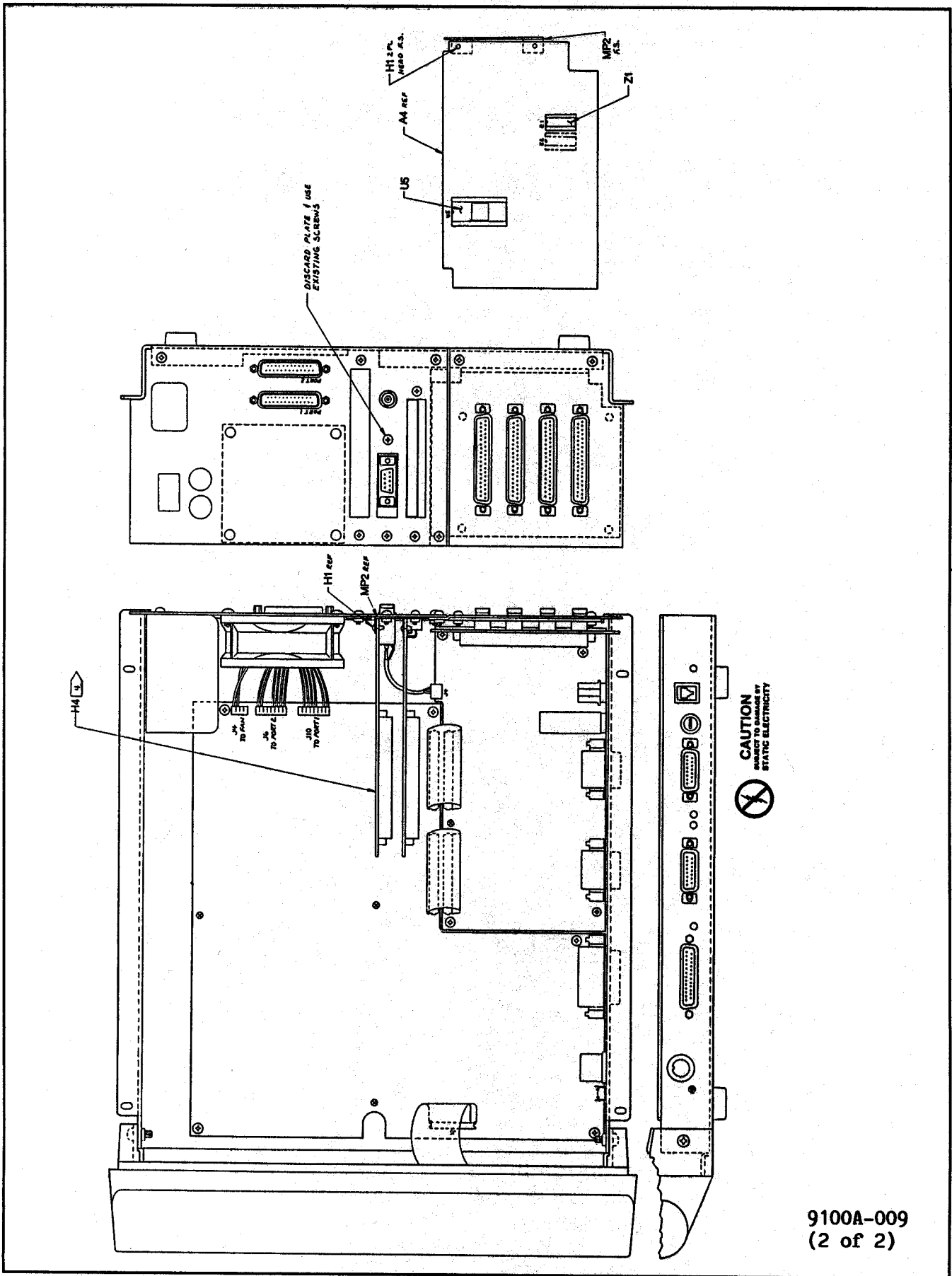

9100A-009
(2 of 2)

Figure 5-17. Option -009 Video, Monochrome (cont.)

5/List of Replaceable Parts

Table 5-24. Option -011 Video, Color
(See Figure 5-18.)

REFERENCE DESIGNATOR		FLUKE STOCK	MFRS SPLY	MANUFACTURERS PART NUMBER	TOT QTY	N R O S T -Q -E-
-A>-NUMERICS	S	--NO--	-CODE-	-OR GENERIC TYPE-		
A	4	*	VIDEO CONTROLLER PCA	768762 89536 768762	1	
H	1		RIVET, POP, DOME, AL, 0.125X0.316	423616 89536 423616	2	
MP	2		VIDEO CONNECTOR BRACKET	768648 89536 768648	1	
U	5	*	PROGRAMMED 27128-150	818195 89536 818195	1	
Z	2		JUMPER, DIP, 0.300CTR, PROGRAM, 16 POS	783183 89536 783183	1	

An * in 'S' column indicates a static-sensitive part.

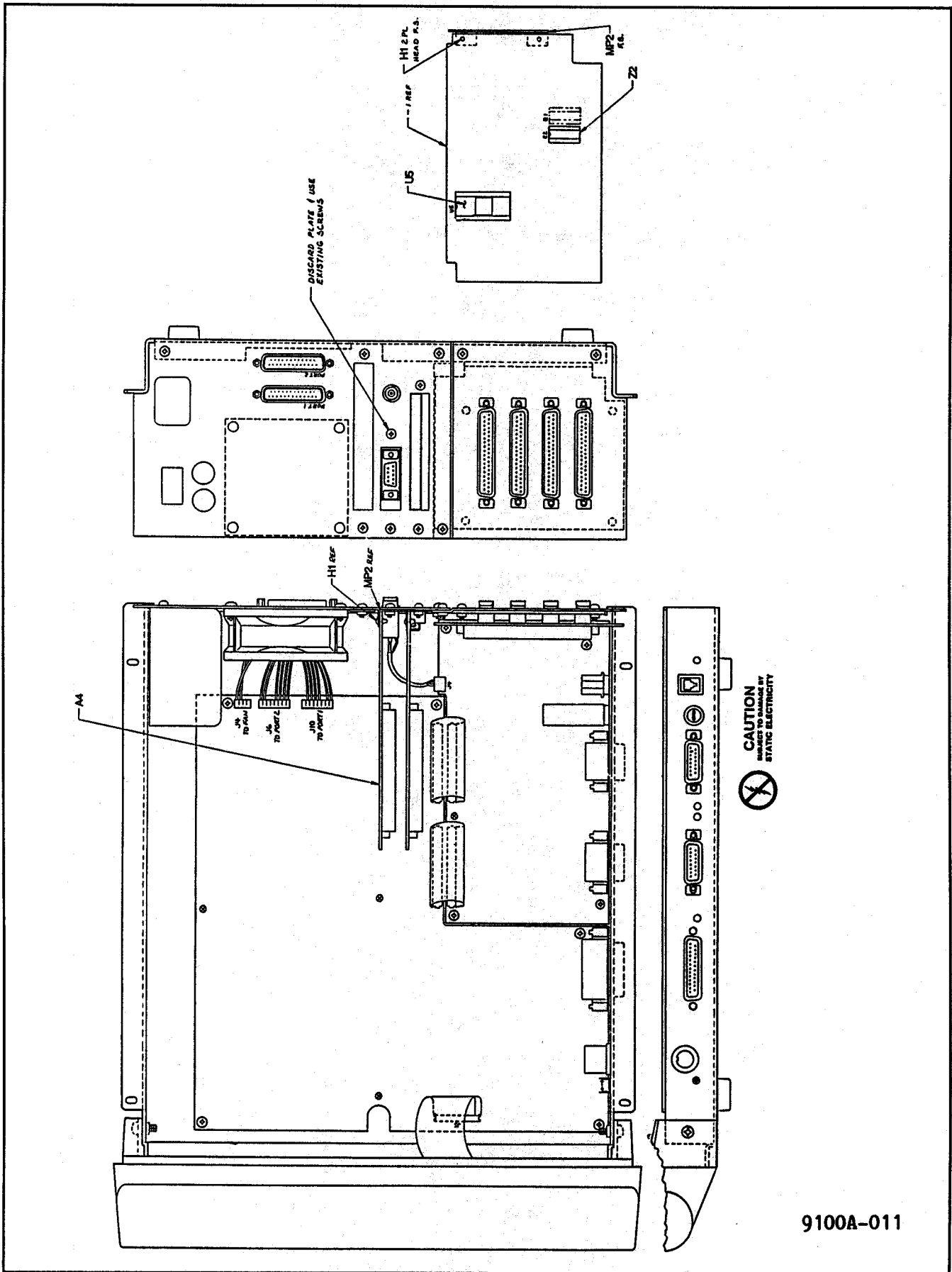

9100A-011

Figure 5-18. Option -011 Video, Color

5/List of Replaceable Parts

Table 5-25. Option -013 Programmer's Keyboard

REFERENCE DESIGNATOR		FLUKE STOCK	MFRS SPLY	MANUFACTURERS PART NUMBER	TOT QTY	R S	O T	N E
-A> NUMERICS	S	--NO--	-CODE-	-OR GENERIC TYPE-		-Q	-E-	
	DESCRIPTION							
MP 1	* ENCODER ASSEMBLY	783092	89536	783092	1			
MP 2	* MEMBRANE SWITCH ASSEMBLY	783076	89536	783076	1			
MP 3	KEYCAP SET	783118	89536	783118	1			
MP 4	TOP CASE	783035	89536	783035	1			
MP 5	BASE	783084	89536	783084	1			
W 1	CABLE	783043	89536	783043	1			

An * in 'S' column indicates a static-sensitive part.

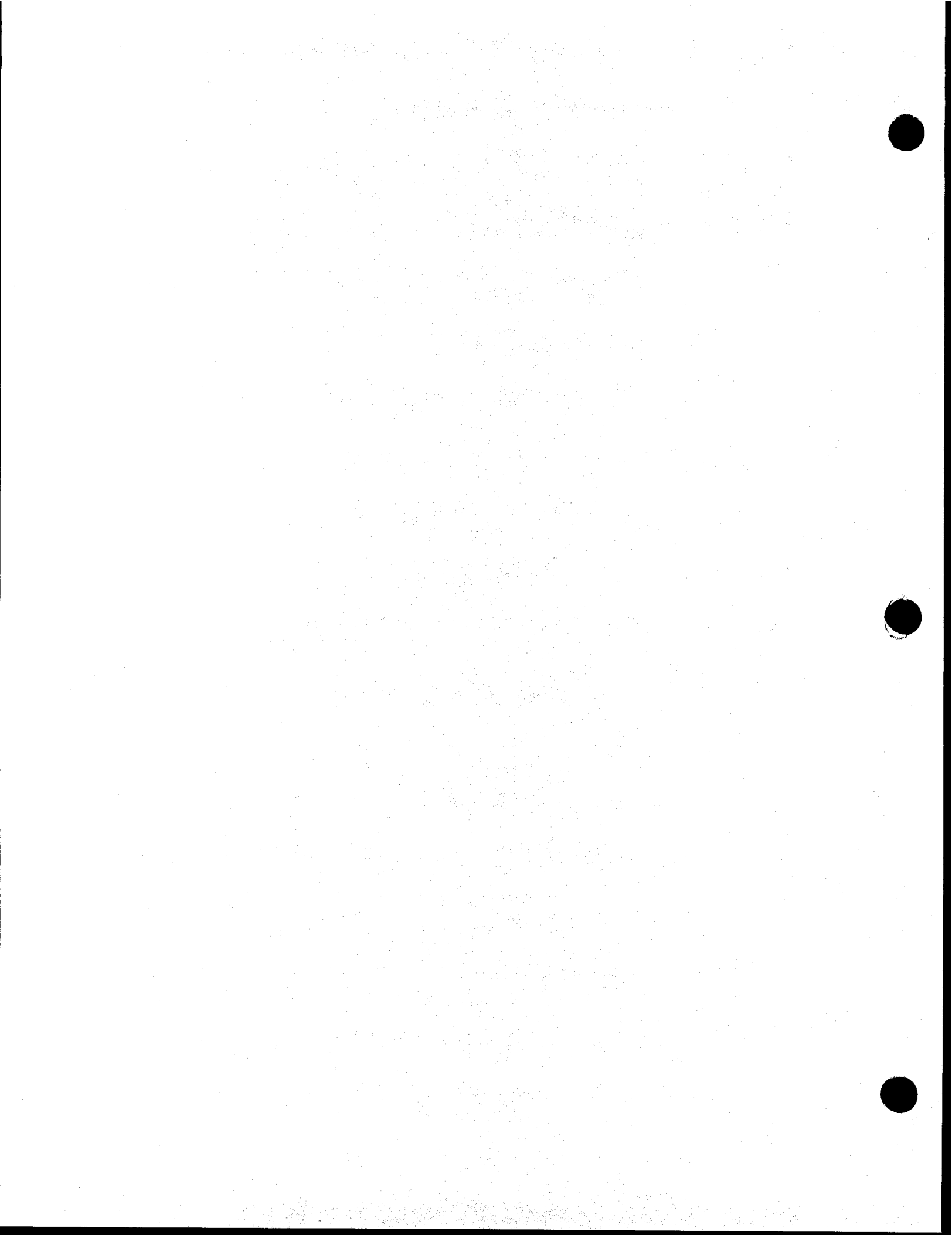

CONTENTS

Appendix A. Federal Supply Codes A-1
Appendix B. Fluke Sales and Service Centers B-1
Appendix C. Assembly Revision Information C-1

Appendix 6A
Federal Supply Codes

Federal Supply Codes for Manufacturers (cont)

08261 Spectra Strip Corp. Garden Grove, California	11726 Qualidyne Corp. Santa Clara, California	13606 Use 56289 Sprague Electric Co. Transistor Div. Concord, New Hampshire	16299 Corning Glass Electronic Components Div. Raleigh, North Carolina
08530 Reliance Mica Corp. Brooklyn, New York	12014 Chicago Rivet & Machine Co. Bellwood, Illinois	13839 Replaced by 23732	16332 Replaced by 28478
08808 General Electric Co. Miniature Lamp Products Dept Cleveland, Ohio	12040 National Semiconductor Corp. Danbury, Connecticut	14099 Semtech Corp. Newbury Park, California	16473 Cambridge Scientific Ind. Div. of Chemed Corporation Cambridge, Maryland
08863 Nylomatic Corp. Norristown, Pennsylvania	12060 Diodes, Inc. Chatsworth, California	14140 Edison Electronic Div. Mc Gray-Edison Co. Manchester, New Hampshire	16742 Paramount Plastics Fabricators, Inc. Downey, California
08998 Use 53085 Skottie Electronics Inc. Archbald, Pennsylvania	12136 Philadelphia Handle Co. Camden, New Jersey	14193 Cal-R-Inc. formerly California Resistor, Corp. Santa Monica, California	16758 Delco Electronics Div. of General Motors Corp. Kokomo, Indiana
09214 G.E. Co. Semi-Conductor Products Dept. Power Semi-Conductor Products OPN Sec. Auburn, New York	12300 Potter-Brumfield Div. AMF Canada LTD. Guelph, Ontario, Canada	14298 American Components, Inc. an Insilco Co. Conshohocken, Pennsylvania	17001 Replaced by 71468
09353 C and K Components Watertown, Massachusetts	12323 Presin Co., Inc. Shelton, Connecticut	14655 Cornell-Dublier Electronics Division of Federal Pacific Electric Co. Govt. Control Dept. Newark, New Jersey	17069 Circuit Structures Lab. Burbank, California
09423 Scientific Components, Inc. Santa Barbara, California	12327 Freeway Corp. formerly Freeway Washer & Stamping Co. Cleveland, Ohio	14752 Electro Cube Inc. San Gabriel, California	17338 High Pressure Eng. Co., Inc. Oklahoma City, Oklahoma
09922 Burndy Corp. Norwalk, Connecticut	12443 The Budd Co. Polychem Products Plastic Products Div. Bridgeport, Pennsylvania	14869 Replaced by 96853	17545 Atlantic Semiconductors, Inc. Asbury Park, New Jersey
09999 Dale Electronics Inc. Yankton, S. Dakota	12615 U.S. Terminals Inc. Cincinnati, Ohio	14936 General Instrument Corp. Semi Conductor Products Group Hicksville, New York	17856 Silliconix, Inc. Santa Clara, California
10059 Barker Engineering Corp. Formerly Amerace, Amerace ESNA Corp. Kenilworth, New Jersey	12617 Hamlin Inc. Lake Mills, Wisconsin	15636 Elec-Trol Inc. Saugus, California	17870 Replaced by 14140
11236 CTS of Berne Berne, Indiana	12697 Clarostat Mfg. Co. Dover, New Hampshire	15801 Fenwal Electronics Inc. Div. of Kiddle Walter and Co., Inc. Framingham, Massachusetts	18178 Vactec Inc. Maryland Heights, Missouri
11237 CTS Keene Inc. Paso Robles, California	12858 Micrometals Sierra Madre, California	15818 Teledyne Semiconductors, formerly Ameico Semiconductor Mountain View, California	18324 Signetics Corp. Sunnyvale, California
11358 CBS Electronic Div. Columbia Broadcasting System Newburyport, Minnesota	12954 Dickson Electronics Corp. Scottsdale, Arizona	15849 Lilton Systems Inc. Useco Div. formerly Useco Inc. Van Nuys, California	18612 Vishay Resistor Products Div. Vishay Intertechnology Inc. Malvern, Pennsylvania
11403 Best Products Co. Chicago, Illinois	12969 Unitrode Corp. Watertown, Massachusetts	15898 International Business Machines Corp. Essex Junction, Vermont	18738 Voltronics Corp. Hanover, New Jersey
11503 Keystone Columbia Inc. Warren, Michigan	13103 Thermalloy Co., Inc. Dallas, Texas	15909 Replaced by 14140	18927 GTE Sylvania Inc. Precision Material Group Parts Division Titusville, Pennsylvania
11532 Teledyne Relays Hawthorne, California	13327 Solitron Devices Inc. Tappan, New York	16258 Space-Lok Inc. Burbank, California	19451 Perine Machinery & Supply Co. Seattle, Washington
11711 General Instrument Corp. Rectifier Division Hicksville, New York	13511 Amphenol Cadre Div. Bunker-Ramo Corp. Los Gatos, California		19701 Electro-Midland Corp. Mepco-Electra Inc. Mineral Wells, Texas
			20584 Enochs Mfg. Inc. Indianapolis, Indiana

Federal Supply Codes for Manufacturers (cont)

20891
Self-Organizing Systems, Inc.
Dallas, Texas

21604
Bucheye Stamping Co.
Columbus, Ohio

21845
Solitron Devices Inc.
Transistor Division
Riviera Beach, Florida

22787
ITT Semiconductors
Palo Alto, California

23050
Product Comp. Corp.
Mount Vernon, New York

23732
Tracor Inc.
Rockville, Maryland

23880
Stanford Applied Engrng.
Santa Clara, California

23936
Pamotor Div., Wm. J. Purdy Co.
Burlingame, California

24248
Replaced by 94222

24355
Analog Devices Inc.
Norwood, Massachusetts

24655
General Radio
Concord, Massachusetts

24759
Lenox Fugle Electronics Inc.
South Plainfield, New Jersey

25088
Siemen Corp.
Isilen, New Jersey

25403
Amperex Electronic Corp.
Semiconductor &
Micro-Circuits Div.
Slatersville, Rhode Island

27014
National Semiconductor Corp.
Santa Clara, California

27284
Molex Products
Downers Grove, Illinois

28213
Minnesota Mining & Mfg. Co.
Consumer Products Div.
St. Paul, Minnesota

28425
Serv-/Link formerly
Bohannon Industries
Fort Worth, Texas

28478
Deltrol Controls Div.
Deltrol Corporation
Milwaukee, Wisconsin

28480
Hewlett Packard Co.
Corporate HQ
Palo Alto, California

28520
Heyman Mfg. Co.
Kenilworth, New Jersey

29083
Monsanto, Co., Inc.
Santa Clara, California

29604
Stackpole Components Co.
Raleigh, North Carolina

30148
AB Enterprise Inc.
Ahoskie, North Carolina

30323
Illinois Tool Works, Inc.
Chicago, Illinois

31091
Optimax Inc.
Colmar, Pennsylvania

32539
Mura Corp.
Great Neck, New York

32767
Griffith Plastic Corp.
Burlingame, California

32879
Advanced Mechanical
Components
Northridge, California

32897
Erie Technological Products, Inc.
Frequency Control Div.
Carlisle, Pennsylvania

32997
Bourns Inc.
Trimpot Products Division
Riverside, California

33173
General Electric Co.
Products Dept.
Owensboro, Kentucky

34333
Silicon General
Westminister, California

34335
Advanced Micro Devices
Sunnyvale, California

34802
Electromotive Inc.
Kenilworth, New Jersey

37942
P.R. Mallory & Co., Inc.
Indianapolis, Indiana

42498
National Radio
Melrose, Massachusetts

43543
Nytronics Inc.
Transformer Co. Div.
Geneva, New York

44655
Ohmite Mfg. Co.
Skokie, Illinois

49671
RCA Corp.
New York, New York

49858
Raytheon Company
Lexington, Massachusetts

50088
Mostek Corp.
Carrollton, Texas

50579
Litronix Inc.
Cupertino, California

51805
Scientific Components Inc.
Linden, New Jersey

53021
Sangamo Electric Co.
Springfield, Illinois

54294
Cutler-Hammer Inc. formerly
Shallcross, A Cutler-Hammer Co.
Selma, North Carolina

55026
Simpson Electric Co.
Div. of Am. Gage and Mach. Co.
Elgin, Illinois

56289
Sprague Electric Co.
North Adams, Massachusetts

58474
Superior Electric Co.
Bristol, Connecticut

60399
Torin Corp. formerly
Torrington Mfg. Co.
Torrington, Connecticut

63743
Ward Leonard Electric Co., Inc.
Mount Vernon, New York

64834
West Mfg. Co.
San Francisco, California

65092
Weston Instruments Inc.
Newark, New Jersey

66150
Winslow Tele-Tronics Inc.
Eaton Town, New Jersey
70485
Atlantic India Rubber Works
Chicago, Illinois

70583
Amperite Company
Union City, New Jersey

70903
Belden Corp.
Geneva, Illinois

71002
Birnbach Radio Co., Inc.
Freeport, New York

71400
Bussmann Mfg.
Div. of McGraw-Edison Co.
Saint Louis, Missouri

71450
CTS Corp.
Elkhart, Indiana

71468
ITT Cannon Electric Inc.
Santa Ana, California

71482
Clare, C.P. & Co.
Chicago, Illinois

71590
Centrelab Electronics
Div. of Globe Union Inc.
Milwaukee, Wisconsin

71707
Coto Coil Co., Inc.
Providence, Rhode Island

71744
Chicago Miniature Lamp Works
Chicago, Illinois

71785
TRW Electronics Components
Cinch Connector Operations Div.
Elk Grove Village
Chicago, Illinois

72005
Wilber B. Driver Co.
Newark, New Jersey

72092
Replaced by 06980

72138
Electro Motive Mfg. Co.
Williamantic, Connecticut

72259
Nytronics Inc.
Pelham Manor, New Jersey

72619
Dialight Div.
Amperex Electronic Corp.
Brooklyn, New York

72653
G.C. Electronics
Div. of Hydrometals, Inc.
Brooklyn, New York

72665
Replaced by 90303
72794
Dzus Fastener Co., Inc.
West Islip, New York

72928
Gulton Ind. Inc.
Gudeman Div.
Chicago, Illinois

Federal Supply Codes for Manufacturers (cont)

72982 Erie Tech. Products Inc. Erie, Pennsylvania	75382 Kulka Electric Corp. Mount Vernon, New York	80583 Hammarlund Mfg. Co., Inc. Red Bank, New Jersey	83594 Burroughs Corp. Electronic Components Div. Plainfield, New Jersey
73138 Bechman Instrument Inc. Helipot Division Fullerton, California	75915 Littlefuse Inc. Des Plaines, Illinois	80640 Arnold Stevens, Inc. South Boston, Massachusetts	83740 Union Carbide Corp. Battery Products Div. formerly Consumer Products Div. New York, New York
73293 Hughes Aircraft Co. Electron Dynamics Div. Torrance, California	76854 Oak Industries Inc. Switch Div. Crystal Lake, Illinois	81073 Grayhill, Inc. La Grange, Illinois	84171 Arco Electronics Great Neck, New York
73445 Amperex Electronic Corp. Hicksville, New York	77342 AMF Inc. Potter & Brumfield Div. Princeton, Indiana	81312 Winchester Electronics Div. of Litton Industries Inc. Oakville, Connecticut	84411 TRW Electronic Components TRW Capacitors Ogallala, Nebraska
73559 Carling Electric Inc. West Hartford, Connecticut	77638 General Instrument Corp. Rectifier Division Brooklyn, New York	81483 Therm-O-Disc Inc. Mansfield, Ohio	84613 Fuse Indicator Corp. Rockville, Maryland
73586 Circle F Industries Trenton, New Jersey	77969 Rubbercraft Corp. of CA. LTD. Torrance, California	81483 International Rectifier Corp. Los Angeles, California	84682 Essex International Inc. Industrial Wire Div. Peabody, Massachusetts
73734 Federal Screw Products, Inc. Chicago, Illinois	78189 Shakeproof Div. of Illinois Tool Works Inc. Elgin, Illinois	81590 Korry Mfg. Co. Seattle, Washington	86577 Precision Metal Products of Malden Inc. Stoneham, Massachusetts
73743 Fischer Special Mfg. Co. Cincinnati, Ohio	78277 Sigma Instruments, Inc. South Braintree, Massachusetts	81741 Chicago Lock Co. Chicago, Illinois	86684 Radio Corp. of America Electronic Components Div. Harrison, New Jersey
73899 JFD Electronics Co. Components Corp. Brooklyn, New York	78488 Stackpole Carbon Co. Saint Marys, Pennsylvania	82305 Palmer Electronics Corp. South Gate, California	86928 Seastrom Mfg. Co., Inc. Glendale, California
73949 Guardian Electric Mfg. Co. Chicago, Illinois	78553 Eaton Corp. Engineered Fastener Div. Tinnerman Plant Cleveland, Ohio	82389 Switchcraft Inc. Chicago, Illinois	87034 Illuminated Products Inc. Subsidiary of Oak Industries Inc. Anaheim, California
74199 Ouan Nichols Co. Chicago, Illinois	79136 Waldes Kohinoor Inc. Long Island City, New York	82415 North American Phillips Controls Corp. Frederick, Maryland	88219 Gould Inc. Industrial Div. Trenton, New Jersey
74217 Radio Switch Corp. Marlboro, New Jersey	79497 Western Rubber Company Goshen, Indiana	82872 Roanwell Corp. New York, New York	88245 Litton Systems Inc. Useco Div. Van Nuys, California
74276 Signalite Div. General Instrument Corp. Neptune, New Jersey	79963 Zierick Mfg. Corp. Mt. Kisko, New York	82877 Rotron Inc. Woodstock, New York	88419 Cornell-Dubilier Electronic Div. Federal Pacific Co. Fuquay-Varian, North Carolina
74306 Piezo Crystal Co. Carlisle, Pennsylvania	80031 Electro-Midland Corp. Mepco Div. A North American Phillips Co. Norristown, New Jersey	82879 ITT Royal Electric Div. Pawtucket, Rhode Island	88486 Plastic Wire & Cable Jewitt City, Connecticut
74542 Hoyt Elect. Instr. Works Penacook, New Hampshire	80145 LFE Corp., Process Control Div. formerly API Instrument Co. Chesterland, Ohio	83003 Varo Inc. Garland, Texas	88690 Replaced by 04217
74970 Johnson E.F., Co. Waseca, Minnesota	80183 Use 56289 Sprague Products North Adams, Massachusetts	83058 The Carr Co., United Can Div. of TRW Cambridge, Massachusetts	89536 John Fluke Mfg. Co., Inc. Seattle, Washington
75042 TRW Electronics Components IRC Fixed Resistors Philadelphia, Pennsylvania	80294 Bourns Inc., Instrument Div. Riverside, California	83298 Bendix Corp. Electric Power Div. Eatontown, New Jersey	89730 G.E. Co., Newark Lamp Works Newark, New Jersey
75376 Kurz-Kasch Inc. Dayton, Ohio		83330 Herman H. Smith, Inc. Brooklyn, New York	
75378 CTS Knights Inc. Sandwich, Illinois		83478 Rubbercraft Corp. of America, Inc. West Haven, Connecticut	

Federal Supply Codes for Manufacturers (cont)

90201 Mallory Capacitor Co. Div. of P.R. Mallory Co., Inc. Indianapolis, Indiana	91836 King's Electronics Co., Inc. Tuckahoe, New York	95354 Methode Mfg. Corp. Rolling Meadows, Illinois	98291 Selectro Corp. Mamaroneck, New York
90211 Use 56365 Square D Co. Chicago, Illinois	91929 Honeywell Inc. Micro Switch Div. Freeport, Illinois	95712 Bendix Corp. Electrical Components Div. Microwave Devices Plant Franklin, Indiana	98388 Royal Industries Products Div. San Diego, California
90215 Best Stamp & Mfg. Co. Kansas City, Missouri	91934 Miller Electric Co., Inc. Div. of Aunet Woonsocket, Rhode Island	95987 Weckesser Co. Inc. Chicago, Illinois	98743 Replaced by 12749
90303 Mallory Battery Co. Div. of Mallory Co., Inc. Tarrytown, New York	92194 Alpha Wire Corp. Elizabeth, New Jersey	96733 San Fernando Electric Mfg. Co. San Fernando, California	98925 Replaced by 14433
91094 Essex International Inc. Suglex/IWP Div. Newmarket, New Hampshire	93332 Sylvania Electric Products Semiconductor Products Div. Woburn, Massachusetts	96853 Gulton Industries Inc. Measurement and Controls Div. formerly Rustrak Instruments Co. Manchester, New Hampshire	99120 Plastic Capacitors, Inc. Chicago, Illinois
91293 Johanson Mfg. Co. Boonton, New Jersey	94145 Replaced by 49956	96881 Thomson Industries, Inc. Manhasset, New York	99217 Bell Industries Elect. Comp. Div. formerly Southern Elect. Div. Burbank, California
91407 Replaced by 58474	94154 Use 94988 Wagner Electric Corp. Tung-Sol Div. Newark, New Jersey	97540 Master Mobile Mounts, Div. of Whitehall Electronics Corp. Ft. Meyers, Florida	99392 STM Oakland, California
91502 Associated Machine Santa Clara, California	94222 Southco Inc. formerly South Chester Corp. Lester, Pennsylvania	97913 Industrial Electronic Hardware Corp. New York, New York	99515 ITT Jennings Monrovia Plant Div. of ITT Jennings formerly Marshall Industries Capacitor Div. Monrovia, California
91508 Augat Inc. Attleboro, Massachusetts	95146 Alco Electronic Products Inc. Lawrence, Massachusetts	97945 Penwalt Corp. SS White Industrial Products Div. Piscataway, New Jersey	99779 Use 29587 Bunker-Ramo Corp. Barnes Div. Landsdowne, Pennsylvania
91637 Dale Electronics Inc. Columbus, Nebraska	95263 Leecraft Mfg. Co. Long Island City, New York	97968 Replaced by 11358	99800 American Precision Industries Inc. Delevan Division East Aurora, New York
91662 Elco Corp. Willow Grove, Pennsylvania	95264 Replaced by 98278	98094 Replaced by 49956	99942 Centrelab Semiconductor Centrelab Electronics Div. of Globe-Union Inc. El Monte, California
91737 Use 71468 Gremar Mfg. Co., Inc. ITT Cannon/Gremar Santa Ana, California	95275 Vitramon Inc. Bridgeport, Connecticut	98159 Rubber-Teck, Inc. Gardena, California	Toyo Electronics (R-Ohm Corp.) Irvine, California
91802 Industrial Devices, Inc. Edgewater, New Jersey	95303 RCA Corp. Receiving Tube Div. Cincinnati, Ohio	98278 Malco A Microdot Co., Inc. Connector & Cable Div. Pasadena, California	National Connector Minneapolis, Minnesota
91833 Keystone Electronics Corp. New York, New York	95348 Gordo's Corp. Bloomfield, New Jersey		

Appendix 6B
Fluke Sales and Service Centers

U.S. SALES AREAS for all Fluke products**Alabama**

Huntsville
4920 Corporate Drive
Suite J
Huntsville, AL 35805-6202
(205) 837-0581

Arizona

Tempe
2211 S. 48th Street
Suite B
Tempe, AZ 85282
(602) 438-8314

Tucson
(602) 790-9881

California

Burbank
2020 N. Lincoln Street
Burbank, CA 91504
(213) 849-7181

Northern
2300 Walsh Ave., Bldg. K
Santa Clara, CA 95051
(408) 727-0513

San Diego
(619) 292-7657

Southern
P.O. Box 19676
Irvine, CA 92713-9676
16969 Von Karman
Suite 100
Irvine, CA 92714
(714) 863-9031

Colorado

Denver
14180 E. Evans Ave.
Aurora, CO 80014
(303) 695-1000

Connecticut

Hartford
Glen Lochen East
41-C New London Turnpike
Glastonbury, CT 06033
(203) 659-3541

Florida

Clearwater
(813) 799-0087

Miami
(305) 462-1380

Orlando
940 N. Fern Creek Ave.
Orlando, FL 32803
(305) 896-4881

Tampa
(813) 251-9211

Georgia

Atlanta
2700 Delk Road
Suite 150
Marietta, GA 30067
(404) 953-4747

Illinois

Chicago
1150 W. Euclid Avenue
Palatine, IL 60067
(312) 705-0500

Indiana

Indianapolis
8777 Purdue Road
Suite 101
Indianapolis, IN 46268
(317) 875-7870

Louisiana

New Orleans
(504) 455-0814

Massachusetts

Boston
Middlesex Technology Center
900 Middlesex Turnpike
Building 8
Billerica, MA 01821
(617) 663-2400

Maryland

Baltimore
(301) 792-7060

Rockville
5640 Fishers Lane
Rockville, MD 20852
(301) 770-1570

Michigan

Detroit
33031 Schoolcraft
Livonia, MI 48150
(313) 522-9140

Minnesota

Bloomington
1801 E. 79th St.
Suite 9
Bloomington, MN 55420
(612) 854-5526

Missouri

St. Louis
11756 Borman Drive
Suite 160
St. Louis, MO 63146
(314) 993-3805

North Carolina

Greensboro
1310 Beaman Place
Greensboro, NC 27408
(919) 273-1918

New Jersey

Paramus
P.O. Box 930
Paramus, NJ 07653-0930
West 75 Century Road
Paramus, NJ 07652
(201) 262-9550

New Mexico

Albuquerque
(505) 881-3550

New York

Rochester
4515 Culver Road
Rochester, NY 14622
(716) 323-1400

Ohio

Cleveland
Plaza South Three
Suite 402
7271 Engle Road
Middleburg Heights, OH 44130
(216) 234-4540

Oklahoma

Northeast
(405) 236-2977

Oregon

Portland
(503) 227-2042

Pennsylvania

Malvern
200 Lindenwood Drive
Malvern, PA 19355
(215) 647-9550

Pittsburgh
(412) 261-5171

Texas

Austin
(512) 459-3344

Dallas
1801 Royal Lane
Suite 307
Dallas, TX 75229
(214) 869-0311

El Paso
(915) 533-3508

Houston
(713) 240-5995

San Antonio
10417 Gullfdale
San Antonio, TX 78216
(512) 340-0498

Utah

Salt Lake City
(801) 268-9331

Washington

Seattle
5020 148th Ave. N.E.
Suite 110
Redmond, WA 98052
(206) 881-6966

Washington, DC

Washington, DC
(301) 770-1570

INTERNATIONAL SALES OFFICES

Algeria

Bureau de Liaison Philips
(For Philips products)
24 rue Bougainville
El Mouradia, Alger
Tel: 60 14 05
TLX: 62221

Antilles

Philips Antillana N.V.
(For Philips products)
Schottegatweg Oost 146
P.O. Box 3523
Willemstad, Curacao
Tel: 599-9-615277
TLX: 1047

Argentina

Cosin S.A.
(For Fluke products)
Virrey del Pino 4071DPTO E-65
1430 CAP FED
Buenos Aires, Argentina
Tel: (54) (1) 552-5248
TLX: (390) 22284

Philips Argentina S.A.

(For Philips products)
Casilla Correo 3479
Vedia 3892
1430 Buenos Aires
Tel: 54-1-5414106/5417141
TLX: 21359/21243

Australia

Elmeasco Instruments Pty, Ltd.
(For Fluke products)
P.O. Box 30
Concord, N.S.W. 2137
Australia
Tel: (61) (2) 736-2888
TLX: (790) AA25887
FAX: (61) 2-733663

Elmeasco Instruments Pty, Ltd.

(For Fluke products)
P.O. Box 623
12 Maroondah Highway
Ringwood, Victoria 3134
Australia
Tel: (61) (3) 879-2322
TLX: (790) AA30418
FAX: (61) 3-879-4310

Elmeasco Instruments Pty, Ltd.

(For Fluke products)
P.O. Box 274
Salisbury, Qld Australia 4107
Tel: (61) (7) 875-1444
TLX: (790) AA44062

Elmeasco Instruments Pty, Ltd.

(For Fluke products)
P.O. Box 154
Prospect, South Australia 5082
Tel: (61) (8) 344-9000

Elmeasco Instruments Pty, Ltd.

(For Fluke products)
32 Teddington Rd.
Victoria Park
Western Australia 6100
Tel: (61) 9-470-1855

Philips Scientific & Industrial

Equipment Division
(For Philips products)
Centrecourt 25-27 Paul Street
North Ryde
Sydney N.S.W. 2113
Tel: 88 88 222

Austria

**Walter Rekirsch Elektronische
Geräte GmbH & Co.**
(For Fluke products)
Vertrieb KG
Obachgasse 28
1220 Vienna, Austria
Tel: (43) (222) 253626
TLX: (847) 134759
FAX: (43) (222) 257275

Osterreichische Philips Industrie GmbH

(For Philips products)
Geschäftsbereich I & E
Marktbereich Test-und Meßgeräte
A-1101 WIEN, Triester Straße 64
Tel: (0222) 60101/1772 DW

Bahrain

Basma W.L.L.
(For Fluke products)
P.O. Box 5701
Manama, Bahrain
Tel: (973) 251-364
TLX: (955) 9003
FAX: (965) 245218

Bangladesh

Motherland Corporation
(For Fluke products)
24 Hatkhola Road, Tikatuli
Dacca-3, Bangladesh
Tel: 257249, TLX: (950) 642022

Philips Bangladesh Ltd.

(For Philips products)
P.O. Box 62, Ramna
16/17 Kawran Bazar C/A
DHAKA
Tel: 411976
TLX: 65668

Belgium

N.V. Philips Professional Systems S.A.
Test and Measurement
Tweestationsstraat 80
Rue des Deux Gares
Brussel 1070 Bruxelles
Tel: 2-5256111

Bolivia

Cosin Bolivia S.R.L.
(For Fluke products)
Casilla 7295
La Paz, Bolivia
Tel: (591) (2) 40962
TLX: (336) 3233 COALAP BV

Brazil

ATP Hi-Tek Eletronica Ltda.
(For Fluke products)
Al. Amazonas 422, Alphaville
Barueri
CEP 06400, Sao Paulo, Brazil
Tel: (55) (11) 421-5477
TLX: (391) 1171413

Philips do Brasil Ltda.

(For Philips products)
Av. Eng. Luiz Carlos Berrini 3009
Caixa Postal 8681
04571 SAO PAULO S.P.
Tel: 55-11-2411611
TLX: (011) 32750

Brunei

Rank O'Connor's, Sdn Bhd
(For Fluke products)
No. 8 Block D,
Sufri Shophouse Complex
Mile 1 Jalan Tutong
Bandar Seri Begawan
Negara Brunei Darussalam
Tel: (673) (2) 23109 or 23557
TLX: (799) BU2265 RANKOC

Canada

Fluke Electronics Canada Inc.
400 Britannia Rd. East Unit #1
Mississauga, Ontario
L4Z 1X9 Canada
Tel: (416) 890-7600
FAX: (416) 890-6866

Fluke Electronics Canada Inc.

1690 Woodward Drive
Suite 216
Ottawa, Ontario
K2C 3R8 Canada
Tel: (613) 723-9453
FAX: (613) 723-9458

Fluke Electronics Canada Inc.

1255 Trans Canada Highway
Suite 130
Dorval, Quebec
H9P 2V4 Canada
Tel: (514) 685-0022
FAX: (514) 685-0039

Fluke Electronics Canada Inc.

101, 1144 - 29th Ave. N.E.
Calgary, Alberta
T2E 7P1 Canada
Tel: (403) 291-5215
FAX: (403) 291-5219

Chile

Intronica Chile, Ltda.
(For Fluke products)
Casilla 16228
Santiago 9, Chile
Tel: (56) 2-2321886
TLX: (332) 346351

Philips Chilena S.A.

de Produc. Electr.
(For Philips products)
Avenida Santa Maria 0760
Casilla 2687
Santiago De Chile
Tel: 56-2-770038
TLX: 240239

China, Peoples Republic of

Fluke International Corp.
(For Fluke products)
P.O. Box C9090 M/S 206A
Everett, WA 98206 U.S.A.
Tel: (206) 356-5511
TLX: 185103 FLUKE UT
FAX: (206) 356-5116

Colombia

Sistemas E Instrumentacion, Ltda.
(For Fluke products)
Carrera 13, No. 37-43, Of. 401
Ap. Aereo 29583
Bogota DE, Colombia
Tel: (57) 232-4532
TLX: (396) 45787

Industrias Philips de Colombia S.A.

(For Philips products)
Apartado Aereo 4282
Calle 13 No. 51-39
Bogota
Tel: 57-1-2600600
TLX: Philcolon 44776

Cyprus

Chris Radiovision, Ltd.
(For Fluke products)
P.O. Box 1989
Nicosia, Cyprus
Tel: (357) (21) 66121
TLX: (826) 2395

Cyprus, Northern

Ucok Buroteknik
(For Fluke products)
2C & 2D Muftu Ziyai Street
Lefkosa, Northern Cyprus
Mersin 10, Turkey
Tel: (90) (741) 357-20-71777
TLX: (821) 57267

Denmark

Tage Olsen A/S
(For Fluke products)
Ballerup Byvej 222
2750 Ballerup
Denmark
Tel: (45) (2) 658111
TLX: (855) 35293
FAX: (45) 2-680 300

Philips A/S Test & Measurement

(For Philips products)
Prags Boulevard 80
DK-2300-Kobenhavn S
Tel: (01) 572222
TLX: 31201

Ecuador

Proteco Cosin Cia., Ltda.
(For Fluke products)
P.O. Box 228-A
Ave. 12 de Octubre 2285
y Orellana
Quito, Ecuador
Tel: (593) (2) 529684
TLX: (393) 22085

Philips Ecuador S.A.

(For Philips products)
Casilla 343
Paez 118 y Avenida Patria
Quito
Tel: 593-2-546100/546125
TLX: 2227 PHLPSQ ED

Proteco Cosin Cia., Ltda.

(For Fluke products)
P.O. Box 9733
Ave. Principal No. 204 y Calle Segunda
Urbanizacion Miraflores
Guayaquil, Ecuador
Tel: (593) (4) 387519

Egypt and Sudan

**Electronic Engineering
Liaison Office**
(For Fluke products)
P.O. Box 2891 Horreya
11361 Heliopolis, Cairo
Egypt
Tel: (20) 2-695705
TLX: (927) 22762

Philips Egypt Liaison Office of Philips
(For Philips products)
Export B.V.
10, Abdel Rahman el Rafei Str.
P.O. Box 1687
Dokki, Cairo
Tel: 20-2-3490922
TLX: 22816 PHEGY UN

Ethiopia
(For Philips products)
Philips Ethiopia (Priv. Ltd. Co.)
Ras Abebe Areguay Avenue
P.O. Box 2565
Addis Ababa
Tel: 148300

Fiji
Awa New Zealand Ltd.
(For Fluke products)
37 Freestone Walu Bay Road
P.O. Box 858
Suva, Fiji
Tel: (679) 312079
TLX: (792) 2347
FAX: (679) 314379

Finland
Instrumentarium Elektronikka
(For Fluke products)
P.O. Box 64
02631 Espoo 63
Finland
Tel: (358) (0) 5281
TLX: (857) 124426
FAX: (358) 0-502-1073

OY Philips AB
(For Philips products)
P.O. Box 11
02631 ESPOO
Tel. 0-5257225

France
M.B. Electronique S.A.
(For Fluke products)
606 Rue Fournay
P.O. Box 31
78530 BUC, France
Tel: (33) (1) 39568131
TLX: (842) 695414
FAX: (33) (1) 3956-53-44

S.A. Philips Industrielle et Commerciales
Division Science et Industrie
(For Philips products)
105 rue de Paris, BP 62
93002 BOBIGNY Cedex
Tel: (1) 49 42 80 80
TLX: 210290

Germany
Philips GmbH
(For Philips products)
Unternehmensbereich
Elektronik für Wissenschaft
und Industrie
Vertriebsbereich Testr and Meßtechnik
Miramstraße 87 Postfach 310320
D-3500 KASSEL
Tel: (0561) 5010, TLX: 997070

Bereich Fluke Produkts
Oskar-Messter-Strape 18
D-8045 Ismaning

Great Britain
Philips Test & Measurement
York Street
Cambridge CB1 2PX
Tel: (0223) 358866
TLX: 817331

Philips Test & Measurement
(For Fluke products)
Colonial Way
Watford WD2 4TT

Greece
Hellenic Scientific Representations Ltd.
(For Fluke products)
11 Vrassida Street
Athens 612, Greece
Tel: (30) (1) 7211140
TLX: (863) 219330

Philips S.A. Hellenique I&E Division
(For Philips products)
15, 25th March Street
GR-17778 TAVROS or
P.O. Box 3153 Athens
Tel: 30-1-4894911
TLX: 241566-241567

Hong Kong
Fluke Asia Ltd.
(For Fluke products)
Shun Tak Centre
Suite No. 1501
200 Connaught Road
Central, Hong Kong
Tel: (852) 5-482116
FAX: (852) 5-479863
TLX: (780) 87058 Fluke HX

Philips Hong Kong Ltd.
(For Philips products)
29/F Hopewell Centre
17 Kennedy Road
G.P.O. Box 2108
Hong Kong
Tel: 852-5-283298
TLX: 73660 PHILH HX

Schmidt & Co (H.K.), Ltd
(For Fluke products)
18th Floor, Great Eagle Centre
23 Harbour Road
Wanchai, Hong Kong
Tel: (852) (5) 8330-222
TLX: (780) 74766 or 76762
FAX: (852) 5-8918754

India
Hinditron Services Pvt., Ltd.
(For Fluke products)
69/A.L. Jagmohandas Marg
Bombay 400 006, India
Tel: (22) 8121316, (91) (22) 8125344
TLX: (953) 1175326

Hinditron Services Pvt., Ltd.
(For Fluke products)
8th Main Road
33/44A Raj Mahal Vilas Extension
Bangalore 560 080, India
Tel: (91) 812-363139, TLX: (953) 8452741

Hinditron Services Pvt. Ltd.
(For Fluke products)
5th Floor, "Castle House"
5/1A, Hungerford St
Calcutta 700 017, India
Tel: (91) 33-432628, TLX (953) 21-4153

Hinditron Services Pvt. Ltd.
(For Fluke products)
204-5-6 Hemkunt Tower
98 Nehru Place
New Delhi, 110019, India
Tel: (91) 11-6410380, TLX: (953) 316458

Hinditron Services Pvt., Ltd.
(For Fluke products)
Emerald Complex 1-7-264
5th Floor
114 Sarojini Devi Rd.
Secunderabad 500 003, India
Tel: 842 821117, TLX: (953) 04256973

Peico Electronics & Electricals Ltd.
(For Philips products)
Shivsagar Estate, Block 'A'
Dr. Annie Besant Road
P.O.B. 6598
Worli, Bombay 400018
Tel: 4921500/4921513

Indonesia
P.T. Lamda Triguna
(For Fluke products)
Tel: (62) 21-8195365
TLX: (796) 45483 LOMAS I.A.
P.O. Box: 6/JATJG, Jakarta 13001

P.T. Daeng Brothers
(For Philips products)
Centre Point Building, 3rd Fl.
Jalan Gatot Subroto Kav. 35/36
P.O. Box 41 Tebet
Jakarta
Tel: 62-21-517900
TLX: 62798 PHDC IA

Iran
Philips Iran Ltd.
(For Philips products)
(Private Joint Stock Comp.)
P.O. Box 11365-3891
Tehran
Tel: 98-21-674138
TLX: 212545 PHPS IR

Iraq
Philips Midden Oosten B.V.
(For Philips products)
Baghdad Branch
Hai Al Whida. Area No. 902
Street No. 12, Bldg. 141/10
P.O. Box 5749
Baghdad
Tel: 7187181
TLX: 212439 Philips IK

Ireland
Circuit Specialists Limited
(For Fluke products)
Unit 5 Enterprise Centre
Plassey Technological Park
Castleroy, Limerick
Ireland
Tel: (852) (61) 330333
TLX: (852) 70092

P.J. Brennan and Company Ltd.
(For Philips products)
61 Stillorgan Industrial Park
Stillorgan, Co. Dublin
Tel: 952501
TLX: 3817
FAX: 952333

Israel
R.D.T. Electronics Engineering Ltd.
P.O. Box 43137
Tel Aviv 61430
Israel
Tel: (972) (3) 483211, TLX: 371452
FAX: 972-3-492190

Italy
Sistrel S.p.A.
(For Fluke products)
Via Pelizza da Volpedo 59
20092 Cinisello Balsamo
Milan, Italy
Tel: (39) (2) 6181893, TLX: (843) 336443
FAX: (39) 2-6182440

Sistrel S.p.A.
(For Fluke products)
Via le Erminio Spalla No. 41
00142 Rome, Italy
TLX: (843) 625857, FAX (39) 6-504137

Sistrel S.p.A.
(For Fluke products)
Via Cintia
Parco S. Paolo 35
80126 Naples, Italy
Tel: (39) (81) 7679700
FAX (39) 81-7661361

Philips S.p.A.
(For Philips products)
Sezione S & I, T. & M Dept.
Viale Elvezia 2
20052 Monza
Tel: (039) 3635240/8/9
TLX: 333343

Japan
John Fluke Mfg. Co., Inc.
Japan Branch
(For Fluke products)
Sumitomo Higashi Shinbashi Bldg.
1-1-11 Hamamatsucho
Minato-ku, Tokyo 105, Japan
Tel: (81) (3) 434-0181
TLX: (781) 2424331
FAX: 81-3-434-0170

John Fluke Mfg. Co., Inc.
Japan Branch
(For Fluke products)
Katsushige Building
2-45 Kohraibashi
Higashi-ku, Osaka 541
Japan
Tel: (81) (6) 229-0871
FAX: 81-6-229-1098

NF Circuit Design Block Co., Ltd.
(For Philips products)
3-20 Tsunashima Higashi, 6-Chome,
Kokokuku, Yokohama 223
Tel: (045) 452-0411
TLX: 3823-297

Kenya
Philips (Kenya) Ltd.
(For Philips products)
OL Kalou Road, Industrial Area
P.O. Box 30554
Nairobi
Tel: 254-2-557999, TLX: 22225 Nairobi

Korea, Republic of
Myoung Corporation
 (For Fluke products)
 Yeo Eui Do
 P.O. Box 14
 Seoul, Korea
 Tel: (82) (2) 784-9942
 TLX: MYOUNG K24283
 FAX (82) 2-784-2387

Kuwait
Al Bahar International Group
 (For Fluke products)
 P.O. Box 26672 Safat
 13127 Safat, Kuwait
 Tel: (965) 848601, TLX: (959) 44822

Lebanon and Jordan
Mabek (Electronic Division)
 (For Fluke products)
 P.O. Box 13-5657
 Beirut, Lebanon
 Tel: 812523, TLX: (923) 22889

Philips Middle East S.A.R.L.
 (For Philips products)
 B.P. 11-670
 Ave. Sami Solh
 Beyrouth
 Tel: 392320/1
 TLX: 20765 LE PHIBAN

Malaysia
Mecomb Malaysia SDN BHD
 (For Fluke products)
 P.O. Box 24
 46700 Petaling Jaya
 Selangor, Malaysia
 Tel: (60) 3-7743422, TLX: (784) MA37764
 FAX: (60) 3-774 3414

Philips Malaysia Snd. Bhd./
Wisma Philips
 (For Philips products)
 1st, 2nd, 3rd Floors, 3 Jalan
 SS 15/2a, P.O. Box 12163
 Subang Jaya
 47500 Petaling Jaya
 Tel: 60-3-7345511
 TLX: PHIMAL MA 25111

Malta
Fablan Enterprises
 (For Fluke products)
 20, Msida Road
 Gzira, Malta
 Tel: 513283/40216, TLX: (838) 1837

Mexico
Mexicana de Electronica
Industrial S.A. (MEXEL)
 Diagonal No. 27
 Entre Calle de Eugenia Y Ave.
 Colonia del Valle
 C.P. 03100, Mexico
 Tel: (905) 660-4323, TLX: (383) 1771038

Morocco
Oussama S.A.
 (For Fluke products)
 Angle Boulevard Emile Zola et
 Rue Rethel
 P.O. Box 2007 Casa
 Casablanca, Morocco
 Tel: (212) 24-13-38, TLX: (933) 22730 M

Somaciel
 (For Philips products)
 304 Boulevard Mohamed V,
 Casablanca 05
 Tel: 30 80 51/52
 TLX: 27021

Nepal
Associated Enterprises
 (For Fluke products)
 GPO Box 790, Pyaphal Tole
 Kathmandu, Nepal
 Tel: 13868, TLX: 2568

Netherlands
Philips Nederland
Test en Meetapparaten
 Hoenseweg 55A
 5017 AD TILBURG
 Postbus 115
 5000 AC TILBURG
 Tel: 013-352455
 TLX: 52683

Fluke European Headquarters
 (For Fluke products)
 P.O. Box 2269
 5600 CG Eindhoven
 The Netherlands
 Tel: (40) 458045, TLX: (844) 51846
 FAX: 31-40-457515

New Zealand
Northrop Instruments & Systems Ltd.
 (For Fluke products)
 Information Technology Group
 131 Khyber Pass Road
 Private Bag, Newmarket
 Auckland 1, New Zealand
 Tel: (64) (9) 501-801, TLX: (791) 21570
 FAX: 64-9-543430

Northrop Instruments & Systems Ltd.
 (For Fluke products)
 Information Technology Group
 First Floor, Northrop Bldg.
 189-191 Willis Street
 P.O. Box 2406
 Wellington, New Zealand
 Tel: (64) (4) 856-658, TLX: (791) 3380

Northrop Instruments & Systems Ltd.
 (For Fluke products)
 Information Technology Group
 110 Mandeville Street
 P.O. Box 8388
 Christchurch, New Zealand
 Tel: (64) (3) 488-874, TLX: (791) 4801

Philips New Zealand Ltd.
Industrial & Electro-acoustic
Systems Division
 2 Wagener Place, P.O. Box 4 021
 Auckland 3, New Zealand
 Tel: (09) 894-160
 TLX: NZ 2395, FAX: (9) 862-728

Nigeria
Associated Electronic Products
(Nigeria) Ltd.
 (For Philips products)
 KM 16, Ikorodu Road, Ojota
 P.O. Box 1921
 Lagos
 Tel: 234-1-900160/69
 TLX: 21961 NG

Norway
Morgenstjerne & Co A/S
 (For Fluke products)
 Konghellegate 3
 P.O. Box 8688, Rodelokka
 Oslo 5, Norway
 Tel: (47) (2) 356110, TLX: (856) 71719
 FAX: (47) 2-381457

Norsk AI/S Philips
 (For Philips products)
 Dept. I&E, Test & Measurement
 Sandstuveien 70, P.O. Box 1
 Manglerud
 Oslo 6
 Tel: 2-680200

Oman
OHI Telecommunications
 (For Fluke products)
 P.O. Box 889
 Muscat, Oman
 Tel: (968) 603606, TLX: (926) 5052

Pakistan
International Operations
(PAK Private), Ltd.
 (For Fluke products)
 505 Muhammadi House
 I.I. Chundrigar Road
 P.O. Box 5323, Karachi, Pakistan
 Tel: (21) 221127, TLX: (952) 24494

Philips Electrical Co. of Pakistan Ltd.
 (For Philips products)
 P.O. Box 7101
 M.A. Jinnah Road
 Karachi 3
 Tel: 92-21-725772
 TLX: 2874 PHPAK PK

Paraguay
Philips del Paraguay S.A.
 (For Philips products)
 Avenida Artigas 1519
 Casilla de Correo 605
 Asuncion
 Tel: 595-21-291924
 TLX: PY 215

Peru
Importaciones y Representaciones
Electronicas S.A.
 (For Fluke products)
 Avda. Franklin D. Roosevelt 105
 Lima 1, Peru
 Tel: (51) (14) 28-8650, TLX: (394) 25663

Philips Peruana S.A.
 (For Philips products)
 Av. Alfonso Ugarte 1268
 Lima 5 or Apartado 1841
 Lima 100
 Tel: 51-14-326070
 TLX: 21678 PE PHILPER

Philippines, Republic of
Spark Radio & Electronics, Inc.
 (For Fluke products)
 Greenhills P.O. Box 610
 San Juan, Metro Manila, 3113
 Philippines
 Tel: (2) 775192, TLX: (722 or 732) 27901

Philips Industrial Development Inc.
 (For Philips products)
 2246, Pasong Tamo
 P.O. Box 911
 MCCPO Makati Riagal D
 Metro Manila
 Tel: 63-2-868951

Portugal
Decada Espectral
Equipamentos de Electronica
 (For Fluke products)
 Av. Bombeiros Voluntarios
 Lote 102B, Miraflores/Alges
 1495 Lisbon, Portugal
 Tel: (351) (1) 4103420, TLX: (832) 15515
 FAX: (351) 1-410-1844

Philips Portuguesa, S.A.R.L.,
Divisao de Sistemas Industriais
 (For Philips products)
 e Electri-Acastic
 Outurila-Cavinaxille
 2795 Linda-A-Velha
 Tel: 2190071; TLX: 42987

Saudi Arabia
Electronic Equipment Marketing Co.
 (For Fluke products)
 P.O. Box 3750
 Riyadh, 11481 Saudi Arabia
 Tel: (928) (1) 477-1650, TLX: 401120

Singapore, Republic of
Rank O'Connor's (PTE) Ltd.
 (For Fluke products)
 O'Connor House
 98 Pasir Panjang Road
 Singapore 0511
 Republic of Singapore
 Tel: (65) 4737944, TLX: (786) RS21023

Philips Project Development (S) Pte. Ltd.
 (For Philips products)
 Lorong 1, Toa Payoh
 Singapore 1231, P.O. Box 340
 Toa Payoh Central Post Office
 Singapore 9131
 Tel: 65-3502000
 TLX: Philips RS/21375

South Africa
Protea, PNI
 (For Fluke products)
 P.O. Box 39127
 Bramley 2018
 Republic of South Africa
 Tel: (27) (11) 786-3647
 TLX: (960) 4-24409 SA
 FAX: 27-11-887-1479

South African Philips (Pty) Ltd.
 (For Philips products)
 P.O.B. 7703
 2 Herb Street
 New Doornfontein
 Johannesburg 2000
 Tel: (011) 6179111

South Korea
Philips Industries (Korea) Ltd.
 (For Philips products)
 C.P.O. Box 3680, Philips House
 260-199, Itaewon-Dong
 Yongsan-Ku
 Seoul
 Tel: 82-2-794-5011/5
 TLX: Philkor K 27291

Spain
ESSA
 (For Fluke products)
 Equipos y Sistemas S.A.
 C/Apolonio Morales, 13-B
 Madrid 16, Spain
 Tel: (34) (1) 458-0150, TLX: (831) 42856
 FAX: (34) 1-458-0150

Philips Iberica S.A.E. Dpto
 (For Philips products)
 Aparatos de Medida
 Martinez Villergas 2
 Madrid 28027
 Tel: 404-2200

Sri Lanka
Computerlink Data Systems, Ltd.
 (For Fluke products)
 331 Union Place
 Colombo, 2, Sri Lanka
 Tel: (94) (1) 28641/2, TLX: (954) 22455

Sweden

Philips Foersaeljning AB
 Division Industrielektronik
 Test & Measurement
 S-115 84 Stockholm
 Tel: (08) 782 18 00

Switzerland

Traco Electronic AG
 (For Fluke products)
 Jenatschstrasse 1
 8002 Zurich
 Switzerland
 Tel: (41) (1) 201-0711, TLX: (845) 815570

Philips AG

(For Philips products)
 Test-und Messtechnik
 Postfach
 CH-8027 Zurich
 Tel. (01) 4882390

Syria

Mabek (Electronics Division)
 (For Fluke products)
 P.O. Box 4238
 Damascus, Syria

Philips Moyen-Orient S.A.R.L.

(For Philips products)
 Rue Fardoss 79
 P.O. Box 2442
 Damascus
 Tel. 218605/221650
 TLX: PHISYR 411203 SY

Taiwan

Schmidt Electronics Corp.
 (For Fluke products)
 5th Floor, Cathay Min-Sheng
 Commercial Building,
 344 Min-Sheng East Road
 Taipei 104, Taiwan R.O.C.
 Tel: (886) (2) 501-3468, TLX: (785) 11111
 FAX: (886) 2-5029692

Philips Taiwan Ltd.

(For Philips products)
 150, Tun Hua North Road
 P.O. Box 22978
 Taipei
 Tel: 886-2-7120500
 TLX: 21570 PHILPEI

Tanzania

Philips (Tanzania) Ltd.
 (For Philips products)
 T.D.F.L. Building - 1st Floor
 P.O. Box 20104
 Ohio/Upanga Rd.
 Dar es Salaam
 Tel: 29571/4
 TLX: 41016

Thailand

Measuretronix Ltd.
 (For Fluke products)
 2102/63 Ramkamhaeng Road
 Bangkok 10240
 Thailand
 Tel: (66) (2) 374-2516, TLX: (788) 82796

Philips Electrical Co. of Thailand Ltd.

(For Philips products)
 283, Silom Road
 P.O. Box 961
 Bangkok 10500
 Tel: 66-2-233 6330.9
 TLX: 87327 PHILTHA TH

Tunisia

Selep S.A.R.L.
 (For Fluke products)
 6, Rue de Sparte
 Tunis - 1000 RP
 Tunisia
 Tel: (216) (1) 248093, TLX: (934) 13030

STIET

(For Philips products)
 32bis rue Ben Ghedahem
 Tunis
 Tel: 348666, TLX: 14512

Turkey

Erkman Elektronik Aletler
 (For Fluke products)
 Ticaret Anonim Sirketi
 Necatibey Cad 92/3
 Karakoy, Istanbul, Turkey
 Tel. (90) (1) 1441546, TLX: (821) 24399
 FAX: (90) 1-1497037

Turk Philips Ticaret A.S.

(For Philips products)
 Inonu Caddesi 78/80
 P.K. 504

80074 Beyoglu-Istanbul

Tel: 90-1-1435910
 TLX: 24192 PHTRTR

United Arab Emirates

Haris Al-Afag, Ltd.
 (For Fluke products)
 P.O. Box 8141
 Kamal Hamza Bldg.
 Traffic Police Rd.
 Dubai, U.A.E.
 Tel: (971) 4-283625, TLX: (958) 48168

Philips Middle East

(For Philips products)
 Dubai Intern. Trade Centre,
 11th Floor
 P.O. Box 9269
 Dubai
 Tel: 971-4-377000
 TLX: 46350 PMOA EM

Al-Sanani Cen. Trad. Est.

(For Fluke products)
 P.O. Box 7187
 Abu-Dhabi, U.A.E.
 Tel: (971) (2) 821370
 TLX: (958) 23966

Uruguay

Coasin Uruguay S.A.
 (For Fluke products)
 Libertad 2529
 Casilla de Correo 1400
 Montevideo, Uruguay
 Tel: (598) (2) 789015, TLX: (398) UY23010

Industrias Philips del Uruguay S.A.

(For Philips products)
 Av. Uruguay 1287
 Casilla de Correo 294
 Montevideo
 Tel: 919000
 TLX: PHILURU UY 22296

Venezuela

Coasin C.A.
 (For Fluke products)
 Calle 9 Con Calle 4, Edif Edinurbi
 Apartado de Correos NR-70.136
 Los Ruices
 Caracas 1070-A, Venezuela
 Tel: (58) 2-241-0309, TLX: (395) 21027

Inds. Venezolanas Philips. S.A.

(For Philips products)
 Av. Francisco de Miranda,
 Urb. La Carlota,
 Edif. Centro Empresarial Parque del Este
 Apartado 1167
 Caracas 1010-A
 Tel: 58-2-203,71111
 TLX: 25267 IVPSA VC

Zaire

Philips Electronics S.A.R.L.
 (For Philips products)
 137, Boulevard du 30 juin
 B.P. 16636
 Kinshasa
 Tel: 31693, TLX: 21078 KINSHASA

Zambia

Philips Electrical Zambia Ltd.
 (For Philips products)
 Mwembeshi Road
 P.O. Box 1878
 Lusaka
 Tel: 218511/218701
 TLX: ZA 41220

Zimbabwe

Philips Electrical (Pvt.) Ltd.
 (For Fluke products)
 62 Mutare Road
 P.O. Box 994
 Harare
 Tel: 47211/48031
 TLX: 2236

For countries not listed above:

Philips Export B.V.
I&E Export
 Test & Measuring
 Building HVW-3
 P.O. Box 218
 5600 MD Eindhoven
 The Netherlands
 Tel: +31 40 324842
 TLX: 35000 phic nl
 FAX: +31 40 324898

TECHNICAL SERVICE CENTERS

U.S. Service Locations

California

Fluke Technical Center
46610 Landing Parkway
Fremont, CA 94538
(415) 651-5112

Fluke Technical Center
16969 Von Karman Ave., Suite 100
Irvine, CA 92714
(714) 863-9031

Colorado

Fluke Technical Center
14180 East Evans Ave.
Aurora, CO 80014
(303) 695-1000

Florida

Fluke Technical Center
940 N. Fern Creek Avenue
Orlando, FL 32803
(305) 896-4881

Illinois

Fluke Technical Center
1150 W. Euclid Ave.
Palatine, IL 60067
(312) 705-0500

Maryland

Fluke Technical Center
5640 Fishers Lane
Rockville, MD 20852
(301) 770-1576

New Jersey

Fluke Technical Center
West 75 Century Road
P.O. Box 930
Paramus, NJ 07653-0930
(201) 599-9500

Texas

Fluke Technical Center
1801 Royal Lane, Suite 307
Dallas, TX 75229
(214) 869-0311

Washington

Fluke Technical Center
6920 Seaway Blvd.
Everett, WA 98206
(206) 356-5560

International

Argentina

Coasin S.A.
(For Fluke products)
Virrey del Pino 4071
Buenos Aires, Argentina
Tel: 522-5248

Philips Argentina S.A.
(For Philips products)
Casilla Correo 3479
1000 Buenos Aires
Tel: 542-2411/51

Australia

Elmeasco Instruments Pty Ltd.
(For Fluke products)
P.O. Box 30
Concord, N.S.W. 2137
Australia
Tel: 736-2888

Elmeasco Instruments Pty. Ltd.
(For Fluke products)
P.O. Box 623
Ringwood, VIC 3134
Australia
Tel: 879-2322

Elmeasco Instruments Pty. Ltd.
(For Fluke products)
PO Box 274
Salisbury, Queensland 4107
Australia
Tel: 875-1444

Philips Scientific &
Industrial Equip. Div.
(For Philips products)
Centrecourt 25-27 Paul St.
North Ryde
Sydney N.S.W. 2113
Tel: 88 88 222

Austria

Walter Rekirsch Elektronische
Geräte GmbH & Co.
(For Fluke products)
Vertrieb KG
Obachgasse 28
1220 Vienna, Austria
Tel: 253626

Oesterreichische Philips
Industrie GmbH
(For Philips products)
Abteilung Industrie Elektronik
Triesterstrasse 64
A-1100 Wien
Tel: 645521

Algeria

Bureau de Liaison Philips
(For Philips products)
24 bis rue Bougainville
TI Mouradia, Alger
Tel: 56 56 72

Antillen

Philips Antilana N.V.
(For Philips products)
P.O. Box 523
Willemstad, Curacao
Tel: 414071/74

Bangladesh

Philips Bangla Desh Ltd.
(For Fluke products)
P.O. Box 62
Ramna, Dhaka
Tel: 234280

Belgium

N.V. Philips & Mble Assoc.
Scientific & Industrial Div
70 Rue des Deux Gares
Brussels, Belgium
Tel: 2-525 6111

Brazil

Hi-Tek Electronica Ltda.
(For Fluke products)
Al. Amazonas 422
Alphaville, Barueri
CEP 06400 Sao Paulo, Brazil
Tel: 421-5477

Industias Brasileiras

Philips Ltd.
(For Philips products)
Av. Eng. Luiz Carlos Berrini
3009-7 and. CEP 04571
Sao Paulo S.P.
Tel: 241.1611

Canada

Fluke Electronics Canada Inc.
400 Britannia Rd.
Unit #1
Mississauga, Ontario L4Z 1Y9
Tel: 416-890-7600

Fluke Electronics Canada, Inc.
(For Fluke products)
1255 Trans Canada Highway
Suite 130
Dorval, Quebec H9P 2V4
Tel: 514-685-0022

Fluke Electronics Canada Inc.
(For Fluke products)
101, 1144 29th Ave. N.E.
Calgary, Alberta T2E 7P7
(403) 291-5215

Chile

Intronica Chile Ltda.
(For Fluke products)
Casilla 16228
Santiago 9, Chile
Tel: 2321886

Philips Chilena S.A.
(For Philips products)
Casilla Postal 2687
Santiago de Chile
Tel: 770038

China, Peoples Republic of
Instrimpex - Fluke Service Center
(For Fluke products)
57, Xisi Dong Da Jie
Xicheng-qu
P.O. Box 9085

Beijing
People's Republic of China
Tel: 65-7281

Colombia

Sistemas E Instrumentacion, Ltda.
(For Fluke products)
Carrera 13, No. 37-43, Of. 401
Ap. Aereo 29583
Bogota DE, Colombia
Tel: 232-4532

Denmark

Tage Olson A/S
(For Fluke products)
Ballerup, Byveg 222
2750 Ballerup
Denmark
Tel: 658111

Philips Elektronik Systemer A/S
(For Philips products)
Afd. Industri & Forskning
Prags Boulevard 80-P.B. 1919
DK-2300-Koabenhavn S.
Tel: 572222

Ecuador

Proteco Coasin Cia., Ltda.
(For Fluke products)
P.O. Box 228-A
Ave. 12 de Octubre 2285 y
Orellana
Quito, Ecuador
Tel: 526759

Philips Ecuador S.A.
(For Philips products)
Casilla 343
Quito
Tel: 396100

Egypt and Sudan

Electronic Engineering
Liaison Office
(For Fluke products)
P.O. Box 2891 Horreya
11361 Heliopolis
Cairo, Egypt
Tel: 695705

Philips Egypt Branch

of P.M.O.B.V.
P.O. Box 1687
10 Abadel Rahman el Rafei St.
Dokki, Cairo
Tel: 490922

Ethiopia

Philips Ethiopia
(Priv. Ltd. Co.)
(For Philips products)
Ras Aveve Areguay Avenue
P.O. Box 2565
Addis Ababa
Tel 148300

Finland

Instrumentarium Elektronikka
(For Fluke products)
P.O. Box 64, Vitikka 1
02631 ESPOO 63
Finland
Tel: 358-0-5281

OY Philips AB

(For Philips products)
Kaivokatu 8
P.O. Box 255
00101 Helsinki 10
Tel: 1-7271

France

M.B. Electronique S.A.
(For Fluke products)
606, Rue Fourny
P.O. Box 31
78530 BUC, France
Tel: 9568131

S.A. Philips Industrielle
et Commerciale
Science et Industry
(For Philips products)
105 Rue de Paris
93002 Bobigny
Tel: 48301111

6B/Sales and Service Centers

Germany (F.R.G.)

Philips GmbH
Unternehmensbereich Elektronik
für Wissenschaft und Industrie
Werk für Messtechnik
Oskar-Messner-Straße 18
8045 Ismaning
Deutschland
Tel: (089) 96050

Great Britain

Philips Scientific Test
& Measuring Division
(For Fluke products)
Colonial Way
Watford Hert's WD2 4TT
United Kingdom
Tel: 0923-240511

Pye Unicam Ltd.

(For Philips products)
York Street
Cambridge CB1 2PX
Tel: 923-40511

Greece

Hellenic Scientific
Representations Ltd.
(For Fluke products)
11 Vrassida Street
Athens 612, Greece
Tel: 7211140

Philips S.A. Hellenique

(For Philips products)
P.O. Box 153
54 Ave Syngrou
Athens
Tel: 9215311

Hong Kong

Schmidt & Co (H.K.) Ltd.
(For Fluke products)
18th Fl., Great Eagle Centre
23 Harbour Road
Wanchai, Hong Kong
Tel: 8330-222

Philips Hong Kong Ltd.

(For Philips products)
P.O.B. 2108
27-29 Floor
Hopewill Centre
17, Kennedy Road
Hong Kong
Tel: 5-283298

Iceland

Heimelistaeki SF
(For Philips products)
Saetun 8
Reykjavik
Tel: 24000

India

Hinditron Services Pvt. Ltd.
(For Fluke products)
1st Floor, 17-B, Mahal
Industrial Estate
Mahakali Road Andheri East
Bombay 400 093, India
Tel: 6300043

Hinditron Services Pvt. Ltd.
(For Fluke products)
33/44A Raj Maha Villas Extn.
8th Main Road
Bangalore 560 080, India
Tel: 363139

Hinditron Services Pvt. Ltd.

(For Fluke products)
15 Community Centre
Panchshila Park
New Delhi, 110 017, India
Tel: 6433675

Hinditron Services Pvt. Ltd.

Field Service Center
(For Fluke products)
Emerald Complex 1-7-264
5th Floor
114 Sarojini Devi Road
Secunderabad 500 003, India
Tel: 821117

Peico Electronic &

Electricals Ltd.
(For Philips products)
Shivsagar Estate
Block "A"
Dr. Annie Besant Road
P.O.B. 6598
Worli, Bombay 400 018
Tel: 4921500

Indonesia

P.T. Lamda Triguna
(For Fluke products)
P.O. Box 6/JATJG
Jakarta 13001, Indonesia
Tel: 8195365

P.T. Daeng Brothers

(For Philips products)
Centre Point Bldg - 3rd Floor
Jl Jend. Gatot Suggroto
Kav. 35/36
P.O. Box 41 Tebet
Jakarta 12950
Tel: 517335

Iran

Philips Iran Ltd.
(For Philips products)
P.O.B. 1297
Teheran
Tel: 372081/5

Iraq

Philips Iraq W.L.L.
(For Philips products)
Munir Abbas Building
4th Floor South Gate
P.O. Box 5749
Baghdad
Tel: 880409

Ireland

Philips Electrical
(Ireland) Ltd.
(For Philips products)
Newstead
Clonskeagh, Dublin 14
Tel: 693355

Israel

R.D.T. Electronics
Engineering Ltd.
P.O. Box 43137
Tel Aviv 61430
Israel
Tel: 483211

Italy

Sistrel S.p.A.
(For Fluke products)
Via Pelizza da Volpedo 59
20092 Cinisello Balsamo
Milan, Italy
Tel: 6181893

Philips S.p.A.

(For Philips products)
Sezione S & I T & M Dept.
Viale Elvezia 2
20052 Monza
Tel: (039) 3635.1

Japan

John Fluke Mfg. Co., Inc.
Japan Branch
(For Fluke products)
Sumitomo Higashi Shinbashi Bldg.
1-1-11 Hamamatsucho
Minato-ku, Tokyo 105, Japan
Tel: 434-0181

Nihon Philips Corporation

(For Philips products)
Shuwa Shinagawa Building
26-38 Takanawa 3-chrome
Minato-ku, Tokyo 108
Tel: 4485511

Kenya

Philips (Kenya) Ltd.
(For Philips products)
P.O. Box 30554
Nairobi
Tel: 557999

Korea

Myoung Corporation
(For Fluke products)
Yeo Eui Do P.O. Box 14
Seoul, Korea
Tel: 784-9942

Philips Elelectronics

(Korea) Ltd.
(For Philips products)
C.P.O. Box 3680
Seoul, Korea
Tel: 794-5011/5

Lebanon

Philips Middle East S.A.R.L.
(For Philips products)
P.O. Box 11-670
Beirut
Tel: 285748/9

Malaysia

Mecomb Malaysia Sdn. Bhd.
(For Fluke products)
P.O. Box 24
46700 Petaling Jaya
Selangor, Malaysia
Tel: 774-3422

Electronic System (Malaysia)

Sdn. Bhd.
(For Philips products)
Resource Plaza
No. 4 Persiaran Barat
P.O. Box 12163
Petaling Jaya
Selangor, Kuala Lumpur
Tel 554511/24

Mexico

Mexicana de Electronica
Industrial,
S.A. (Mexel)
(For Fluke products)
Diagonal No. 27
Entre Calle de Eugenia Y Ave
Colonia del Valle
C.P. 03100, Mexico
Tel: 660-4323

Apesa Electronica S.A. de C.V.

(For Philips products)
Apartado Postal 213
C.P. 50140
Toluca Edo de Mexico

Morocco

S.A.M.T.E.L.
(For Philips products)
2 Rue de Bapaume
Casablanca
Tel: 243050

Netherlands

Philips Nederland
Test & Meetapparaten
(For Fluke products)
Hoenseweg 55A,
5017 AD Tilburg
Postbus 115, 5000 AC Tilburg
Nederland
35 24 55

Philips Nederland B.V.

(For Philips products)
Boschdijk 525
Gebouw VB
5600 MD Eindhoven
Tel: 782808

New Zealand

Northrop Instruments
& Systems Ltd.
(For Fluke products)
459 Kyber Pass Road,
Private Bag, Newmarket
Auckland 1, New Zealand
Tel: 501-801

Northrop Instruments

& Systems Ltd.
(For Fluke products)
First Floor, Northrop Bldg.
189-191 Willis Street
P.O. Box 2406
Wellington, New Zealand
Tel: 856-658

Philips Electrical Ind. Ltd.

(For Philips products)
Scientific & Industrial Div
68-86 Jervois Quay
P.O. Box 2097
Wellington C1
Tel: 735735

Nigeria

Associated Electronic Products
(Nigeria) Ltd.
(For Philips products)
Km. 16 Ikorodu Road
Ojota
P.O. Box 1921
Lagos
Tel: 932825

6B/Sales and Service Centers

Norway

Morgenstjerne & Co. A/S
(For Fluke products)
Konghellegate 3
P.O. Box 6688, Rodelokka
Oslo 5, Norway
Tel: 356110

Norsk Akieselskap
Philips Dept.
Industry and
Telecommunication
Sandstuveien 70
P.O. Box 1
Manglerud
Oslo 6
Tel: 2-680200

Pakistan

Pak International Operations
(For Fluke products)
505 Muhammadi House
I.I. Chundrigar Road
P.O. Box 5323
Karachi Pakistan
Tel: 221127/239052

Philips Electrical Industries
of Pakistan Ltd.
(For Philips products)
Philips Markaz
M.A. Jinnah Road
P.O. Box 7101
Karachi 3, Pakistan
Tel: 725772/9

Paraguay

hilips del Paraguay S.A.
(For Philips products)
Av. Artigas 1497
Casilla Correo 605
Asuncion
Tel: 291924

Peru

Importaciones Y Representaciones
Electronicas S.A.
(For Philips products)
Avda. Franklin D. Roosevelt 105
Lima 1, Peru
Tel: 288650

Philips Peruana S.A.
(For Philips products)
Av. Alfonso Ugarte 1268
Apartado 1841
Lima
Tel: 32-6070

Philippines

Spark Radio and Electronics Corp.
(For Fluke products)
Greenhills P.O. Box 610
San Juan Metro-Manila Zip, 3113
Philippines
Tel: 63-2-775192

Philips Industrial Development Inc.
(For Philips products)
2246 Pasong Tamo
Makati, Metro Manila
Tel: 868951

Portugal

Decada Espectral
(For Fluke products)
Equipamentos de Electronica e
Cientificos, SARL
Av. Bombeiros Voluntarios,
Lote 102B
Miraflores/Alges
1495 Lisboa, Portugal
Tel: 2103420

Philips Portuguesa S.A.R.L.
(For Philips products)
Av. Eng. Duarte Pacheco
Appartado 1331
Lisbon-1
Tel: (019) 683121

Singapore

Rank O'Connor's Singapore
(PTE) Ltd.
(For Fluke products)
98 Pasir Panjang Road
Singapore 0511
Republic of Singapore
Tel: 4737944

Philips Project Development
(S) Pte. Ltd.
(For Philips products)
Lorong 1
Toa Payoh
P.O. Box 340
Singapore 1231
Tel: 2538811

South Africa

Fluke S.A. (Pty) Ltd.
P.O. Box 39127
Bramley 2018
Republic of South Africa
Tel: 786-3647

South African Philips
(Pty) Ltd.
(For Philips products)
P.O.B. 7703
2, Herb Street
New Doornfontein, Johannesburg,
2000
Tel: 786-3647

Spain

Equipos Y Sistemas S.A. (ESSA)
(For Fluke products)
C/Apolonio Morales, 13B
Madrid 16, Spain
Tel: 4580150

Philips Iberica S.A.E.
(For Philips products)
Dpto Aparatos de Medida
Marinez Villergas Z Madrid 28027
Tel: 404-2200

Sweden

Svenska A.B. Philips
Div. Industrielektroik
Avd. Matinstrument
11584 Stockholm
Tel: 782-1800

Switzerland

Traco Electronic AG
(For Philips products)
Jenatschstrasse 1
8002 Zurich
Switzerland
Tel: 2010711

Philips AG

(For Philips products)
S & I Equipment
Allmendstasse 140
Postfach 670
CH-8027 Zurich, Switzerland
Tel: 488221

Syria

Philips Moyen-Orient S.A.
(For Philips products)
Rue Fardoss 79
B.P. 2442 Damascus
Tel 221650

Taiwan

Schmidt Electronics Corp.
(For Fluke products)
5th Floor, Cathay Min-Sheng
Commercial Building
344 Min-Sheng East Road
Taipei, Taiwan, R.O.C.
Tel: 5013468

Yung Kang Trading Co. Ltd.
(For Philips products)
11th Floor CTS Building
102 Kuang Fu South Road
P.O.Box 1467
Taipei
Tel: 752-7421

Tanzania

Philips (Tanzania) Ltd.
(For Philips products)
P.O. Box 20104
Dar es Salaam
Tel: 29571

Thailand

Measuretronix Ltd.
(For Fluke products)
2102/63 Ramkhamhaeng Rd.
Bangkok, 10240 Thailand
Tel: 3742516

Philips Electrical Company
of Thailand Ltd.
(For Philips products)
Electronic and Communication
Systems Dept.
283 Silom Road
Bangkok 10
Tel: 233-63330/9

Tunisia

S.T.I.E.T.
(For Philips products)
32 bis
Rue Ben Ghedhahem
Tunis
Tel: 244268

Turkey

Erkman Elektronik Aletler
(For Fluke products)
Ticaret Anonim Sirketi
Necatiby Cad 92/3
Karakoy, Istanbul, Turkey
Tel: 441546

Turk Philips Ticaret A.S.
(For Philips products)
Posta Kutusu 504
Beykoglu Istanbul
Tel: 1435910

United Arab Emirates

Philips Middle East b.v.
(For Philips products)
Dubai Int'l Trade Centre
Level 11
P.O. Box 6269
Dubai
Tel: 377000

Uruguay

Coasin Uruguay S.A.
(For Fluke products)
Casilla de Correo 1400
Libertad 2529
Montevideo, Uruguay
Tel: 789015

Industrias Philips del Uruguay

(For Philips products)
Avda Uruguay 1287
Casilla de Correo 294
Montevideo
Tel: 915641

Venezuela

Coasin C.A.
(For Fluke products)
Calle 9 Con Calle 4
Edif. Edinurbi
Apartado de Correos Nr-70 136
Los Ruices
Caracas 1070-A, Venezuela
Tel: 241-0309

Industias Venezolanas

Philips S.A.
(For Philips products)
Av Ppal de los Ruices
Apartado Postal 1167
Caracas
Tel: 239-3811

Zaire

S.A.M.E. s.z.r.l.
(For Philips products)
B.P. 16636
Kinshasa
Tel: 31693

Zambia

Philips Electrica Zambia Ltd.
(For Philips products)
Mwembeshi Road
P.O. Box 31878
Lusaka
Tel: 218511

Zimbabwe

Philips Electric (Pvt.) Ltd.
(For Philips products)
P.O. Box 994
62 Umtali Road
Beverley, Harare
Tel: 47211

Appendix 6C
Module Revision Information

INTRODUCTION

As changes and improvements are made to the instrument, they are identified by incrementing the revision letter marked on the affected PCA.

These changes are documented on supplemental change/errata sheets which, when applicable, are inserted at the front of the manual. To identify the configuration of the PCAs used in your instrument, refer to the revision letter marked on each PCA.

6C/Module Revision Information

Module Revision Information

Ref	Assembly Name	Fluke Part No.	Revision Level
A1	Main PCA	755520	C2
A2	Display IF PCA	767947	C1
A3	Keypad	755454	D
A4	Video Controller PCA	755553	C1
A5	Probe PCA	755561	E
A6	Clock Module PCA	755579	B
A7	I/O Module (Main) PCA	755587	C
A8	I/O Module (Top) PCA	768747	A2
A9	Probe I/O PCA	768788	G
A10	Multi-Function IF PCA	768721	A1
A11	I/O Connector PCA	767996	A
A16	512K RAM Module	809079	A
-008	Real-Time Clock PCA	768721	A1

Section 7
Schematic Diagrams

TABLE OF CONTENTS

FIGURE	TITLE	PAGE
7-1.	A1 Main PCA	7-3
7-2.	A2 Display Interface PCA	7-7
7-3.	A3 Keypad PCA	7-9
7-4.	A4 Video Controller PCA	7-10
7-5.	A5 Probe PCA	7-12
7-6.	A6 Clock Module PCA	7-13
7-7.	A7 I/O Module (Main) PCA	7-14
7-8.	A8 I/O Module (Top) PCA	7-16
7-9.	A9 Probe I/O PCA	7-17
7-10.	A10 Multi-Function Interface PCA*	7-19
7-11.	A11 I/O Connector PCA	7-20
7-12.	A12 DIP Clip Module (Half)**	7-21
7-13.	A13 DIP Clip Module (Full)	7-22
7-14.	A14 Calibration Module PCA	7-23
7-15.	A16 512K RAM Module	7-24
7-16.	A19 Monochrome Monitor, Block Diagram	7-25
7-17.	-013 Programmer's Keyboard, Block Diagram	7-25
7-18.	Interconnect Diagram, 9100A	7-26
7-19.	Interconnect Diagram, 9105A	7-27

* A10 schematic also used with -008 Real-Time Clock PCA

** A12 schematic also used with A15 Flying Lead Module

D

C

B

A

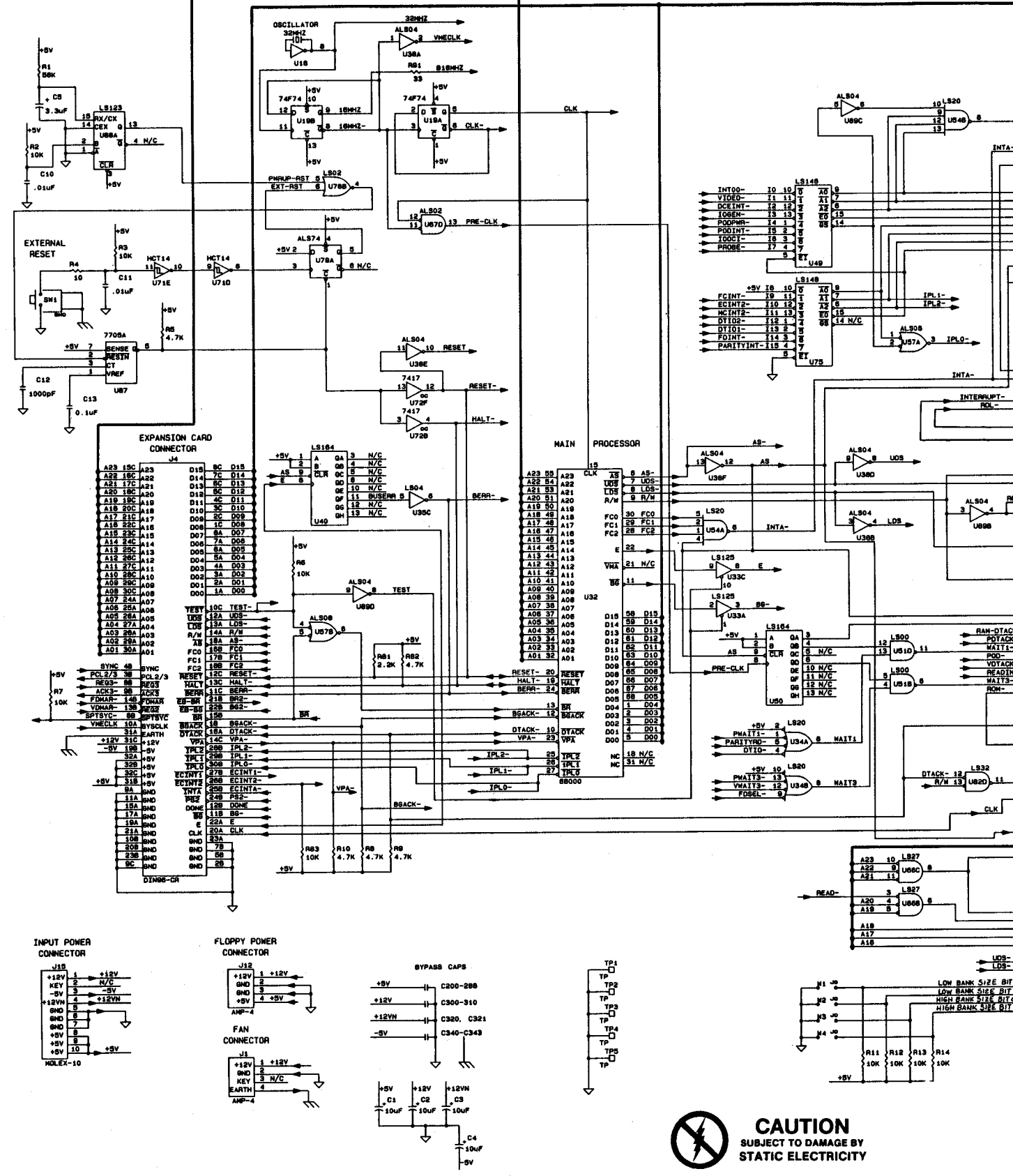

CAUTION
 SUBJECT TO DAMAGE BY
 STATIC ELECTRICITY

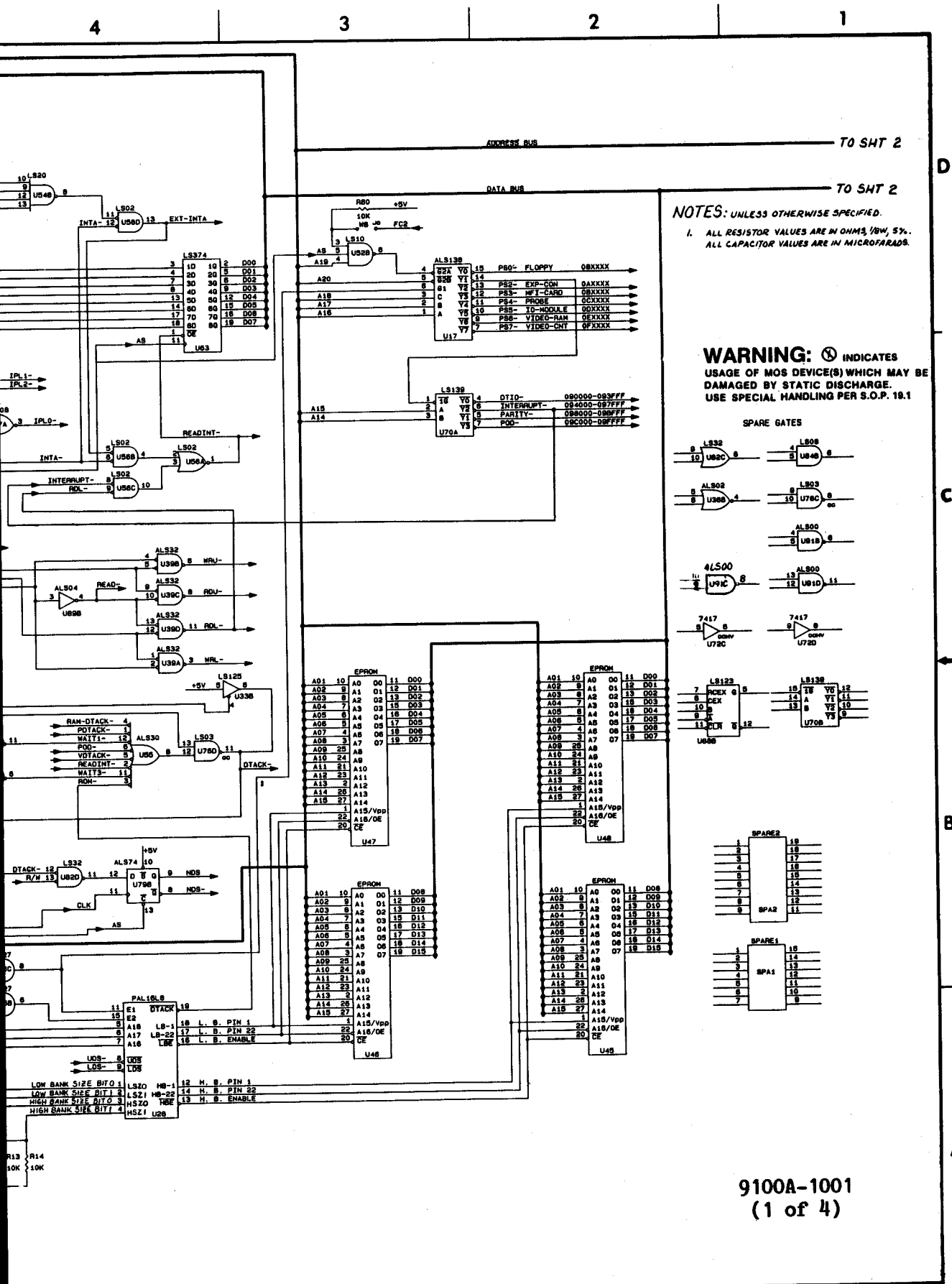

FROM SHT 1 DATA BUS
FROM SHT 1 ADDRESS BUS

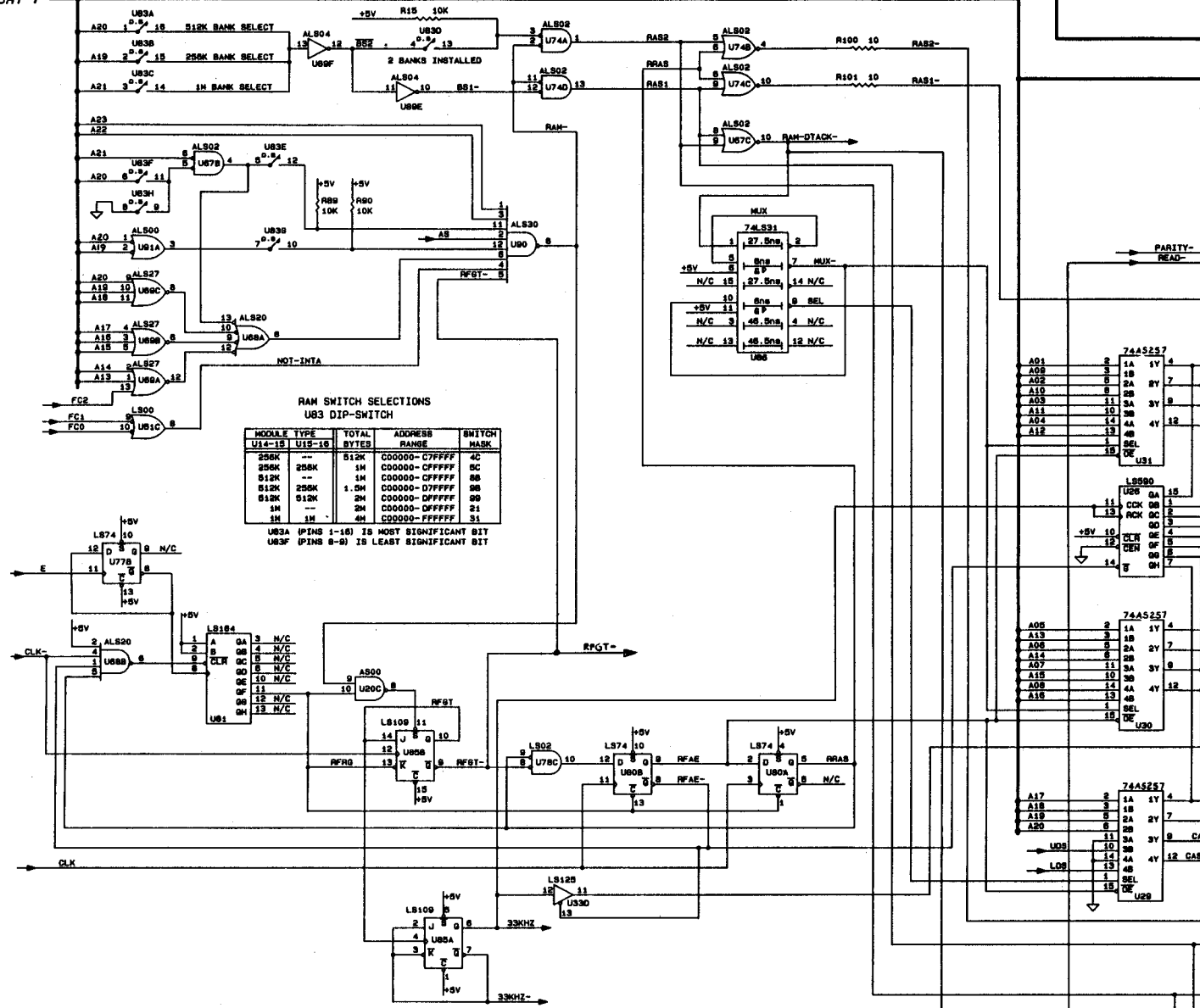

**RAM SWITCH SELECTIONS
U83 DIP-SWITCH**

MODULE TYPE	TOTAL BYTES	ADDRESS RANGE	SWITCH MASK
U14-U18	U15-U18		
256K	256K	000000-07FFFF	4C
512K	512K	000000-C7FFFF	8C
512K	256K	000000-D7FFFF	98
512K	512K	000000-07FFFF	28
1M	1M	000000-07FFFF	21
1M	1M	000000-FFFFF	31

UB3A (PINS 1-18) IS MOST SIGNIFICANT BIT
UB3F (PINS 8-9) IS LEAST SIGNIFICANT BIT

DES	LAST USED	NOT USED
J	J15	J13
W	W4	
U	U91	
Y	Y1	
Q	Q2	
L	L2	
T	T1	
S	S1	
F	F1	
TP	TP11	
CR	CR10	
R	R116	R91-99
C	C380	C7-9, 15, 22, 25-99, 104-109, 114-119, 122-129, 132-199, 289-299, 311-319, 322-339, 344-359, 362-379

4

3

2

1

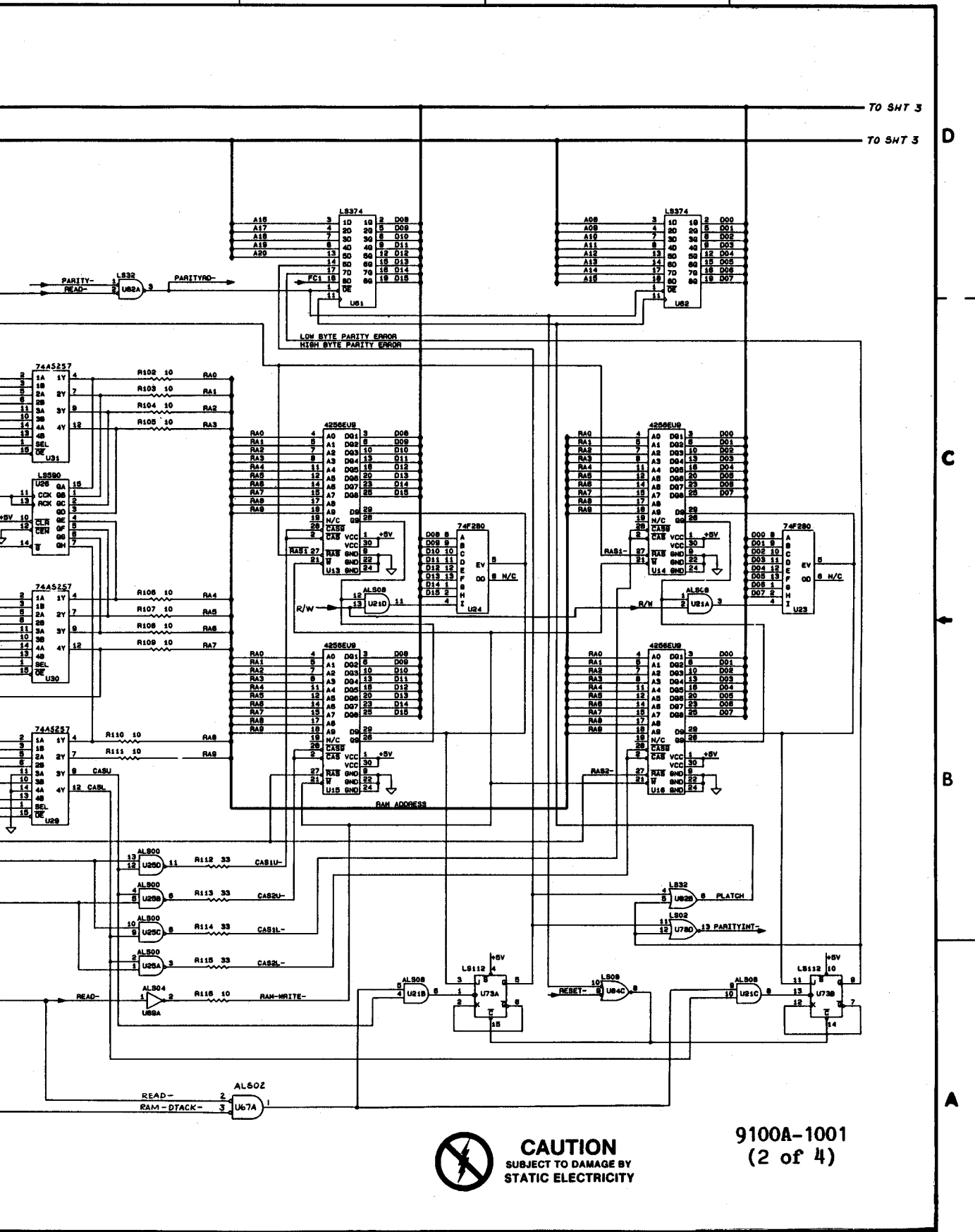

 **CAUTION**
SUBJECT TO DAMAGE BY
STATIC ELECTRICITY

9100A-1001
(2 of 4)

4

3

2

Figure 7-1. A1 Main PCA (cont.)

FROM SHT 2

DATA BUS

D

FROM SHT 2

C

B

A

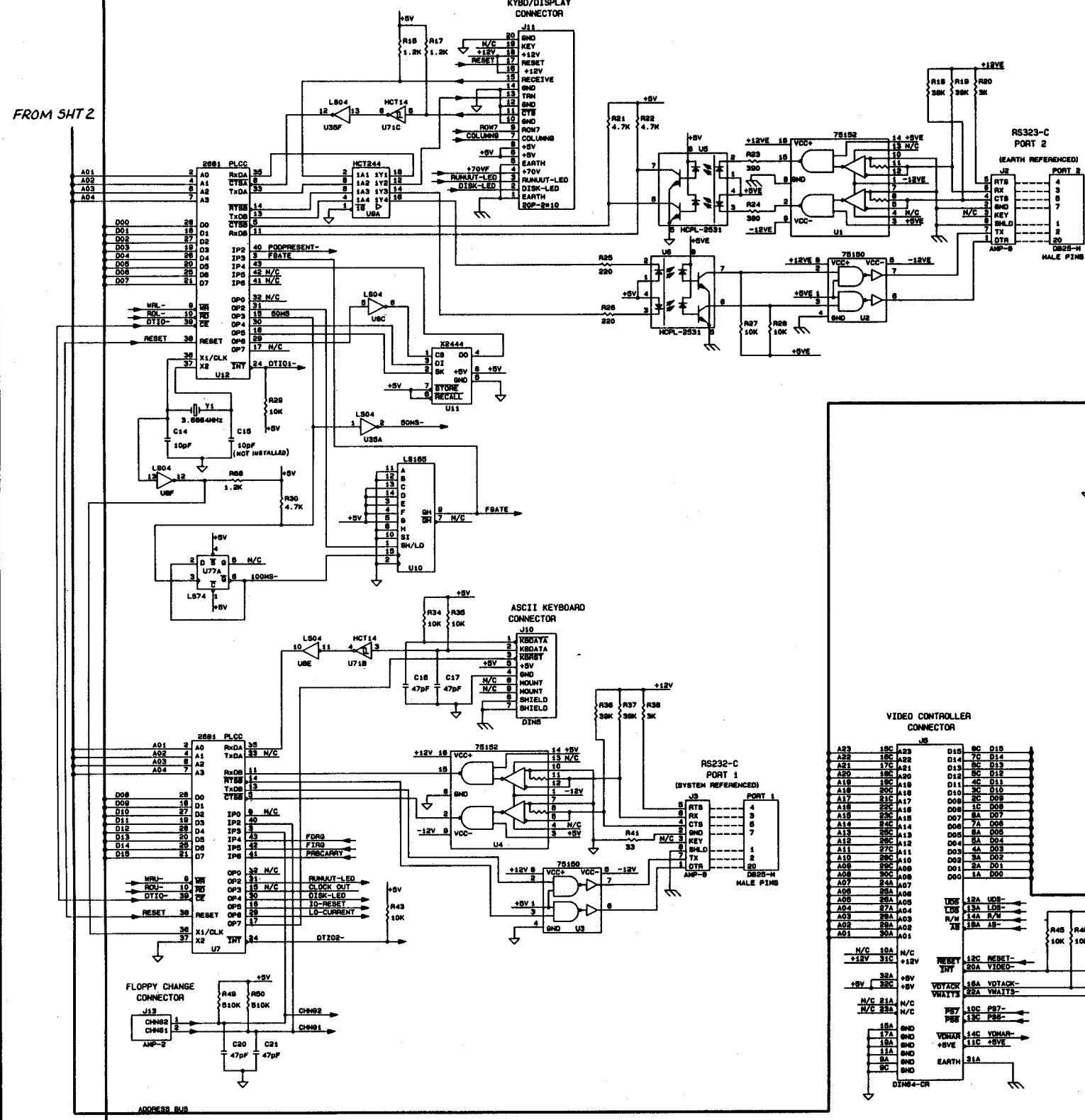

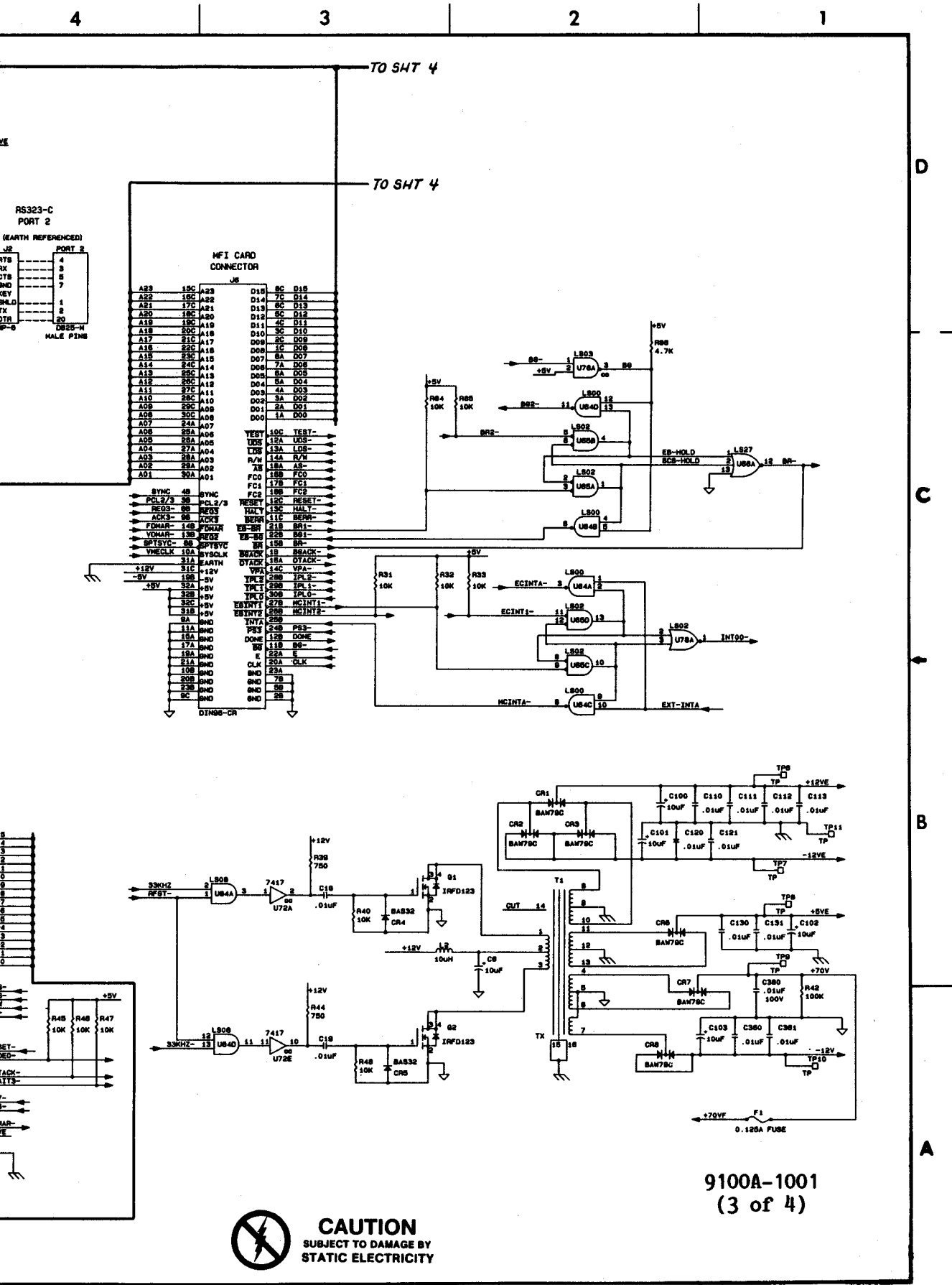

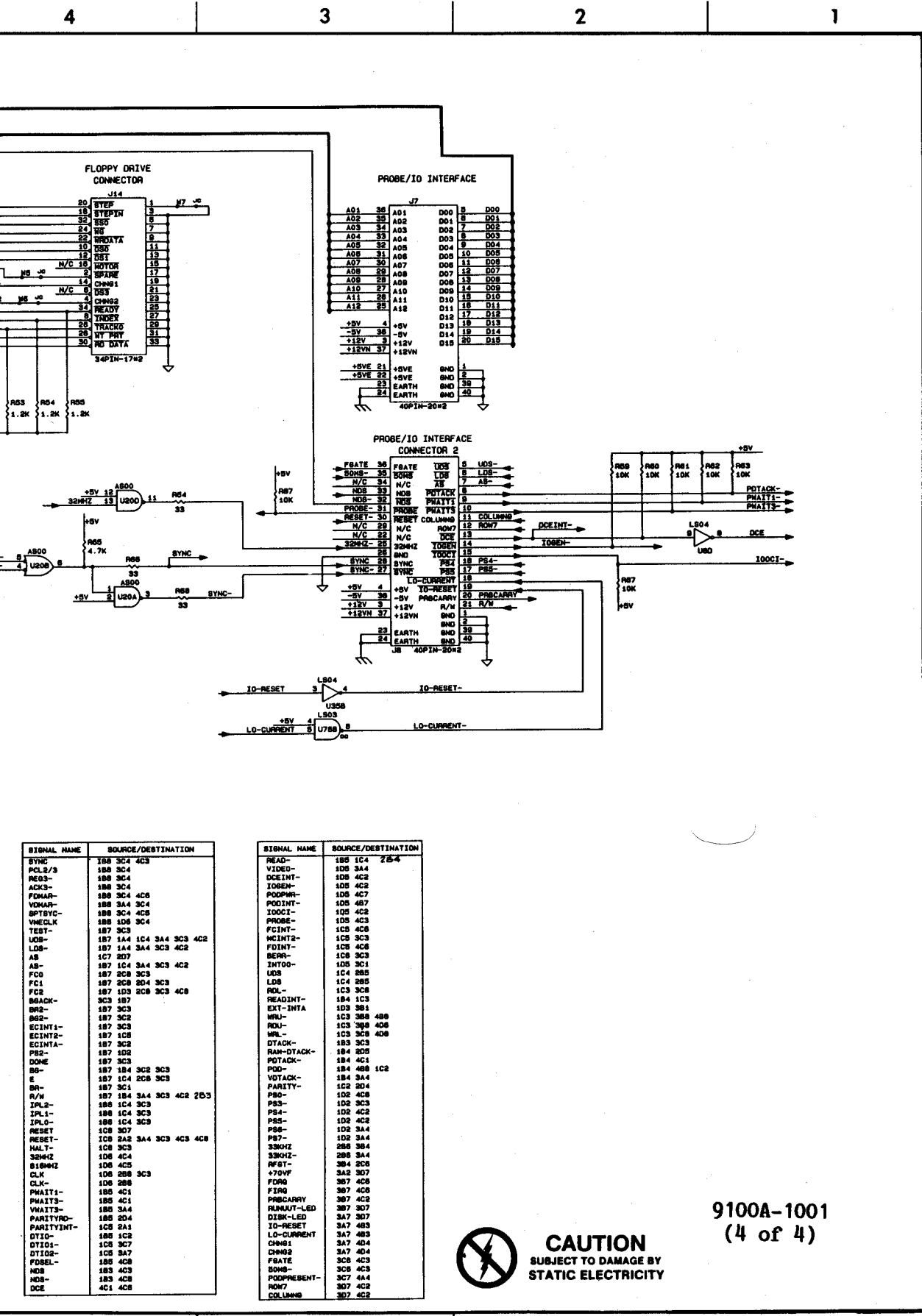

SIGNAL NAME	SOURCE/DESTINATION
SYNC	188 3C4 4C3
PCL2/S	188 3C4
ACK3	188 3C4
FDMAR	188 3C4 4C6
VDMAR	188 3A4 3C4
SPTSYN	188 3C4 4C6
VINECLK	188 1D8 3C4
TEST	187 3C3
LD8-	187 1A4 1C4 3A4 3C3 4C2
LD8-	187 1A4 3A4 3C3 4C2
AS	1C7 2D7
AS-	187 1C4 3A4 3C3 4C2
FC0	187 2C8 3C3
FC1	187 2C8 2D4 3C3
FC2	187 1D3 2C8 3C3 4C6
MBACK-	3C3 187
DB2-	187 3C3
DB2-	187 3C2
ECINT1-	187 3C3
ECINT2-	187 1C6
ECINTA-	187 3C2
P82-	187 1D2
DOME	187 3C3
BB-	187 184 3C2 3C3
S	187 1C4 2C8 3C3
BR-	187 3C1
R/W	187 184 3A4 3C3 4C2 2D3
IPL2-	188 1C4 3C3
IPL1-	188 1C4 3C3
IPL0-	188 1C4 3C3
RESET	1C8 3D7
RESET-	1C8 2A3 3A4 3C3 4C3 4C6
HALT-	1C8 3C3
32MHz	1C8 4C4
818MHz	1C8 4C5
CLK	1C8 288 3C3
CLK-	1C8 288
PHAIT1-	185 4C1
PHAIT3-	185 4C1
PHAIT5-	185 3A4
PARITYD-	185 2D4
PARITYINT-	1C8 2A1
DT1D-	188 1C2
DT1S-	1C8 3C7
DT1O2-	1C8 3A7
FDSEL-	185 4C6
NDB	183 4C3
NDB-	183 4C3
DCE	4C1 4C8

SIGNAL NAME	SOURCE/DESTINATION
READ-	188 1C4 2B-4
VIDEO-	1D8 3A4
DCEINT-	1D8 4C2
IOSEN-	1D8 4C2
POPPMR-	1D8 4C7
PODINT-	1C4 4B7
IOCCI-	1D8 4C2
PROBE-	1D8 4C3
FCINT-	1C8 4C6
NCINT2-	1C8 3C3
FDINT-	1C8 4C6
BERR-	1C8 3C3
INTD0-	1C8 3C1
LD8	1C4 288
LD8	1C3 3C8
READINT-	184 1C3
EXT-INTA	1D8 3B1
WRU-	1C3 388 488
RDU-	1C3 388 408
WRU-	1C3 328 408
DTACK-	183 3C3
RAM-DTACK-	184 2D5
POTACK-	184 4C1
P80-	184 488 1C2
VOTACK-	184 3A4
PARITY-	1C2 2D4
P80-	1D2 4C8
P83-	1D2 3C3
P84-	1D2 4C2
P85-	1D2 4C2
P86-	1D2 3A4
P87-	1D2 3A4
33MHz	288 384
33MHz	288 3A4
P87-	384 2C6
*70VF	387 3D7
FD8Q	387 4C6
FI8Q	387 4C6
P88CARRY	387 4C2
RAMAUT-LED	387 3D7
D18K-LED	3A7 3D7
IO-RESET	3A7 483
IO-CURRENT	3A7 483
CHM1	3A7 4A4
CHM2	3A7 4D4
FBATE	3C8 4C3
SOH8-	3C8 4C3
POPPRESENT-	3C7 4A4
ROM7	3D7 4C2
COLUMN8	3D7 4C2

9100A-1001
(4 of 4)



Figure 7-1. A1 Main PCA (cont.)

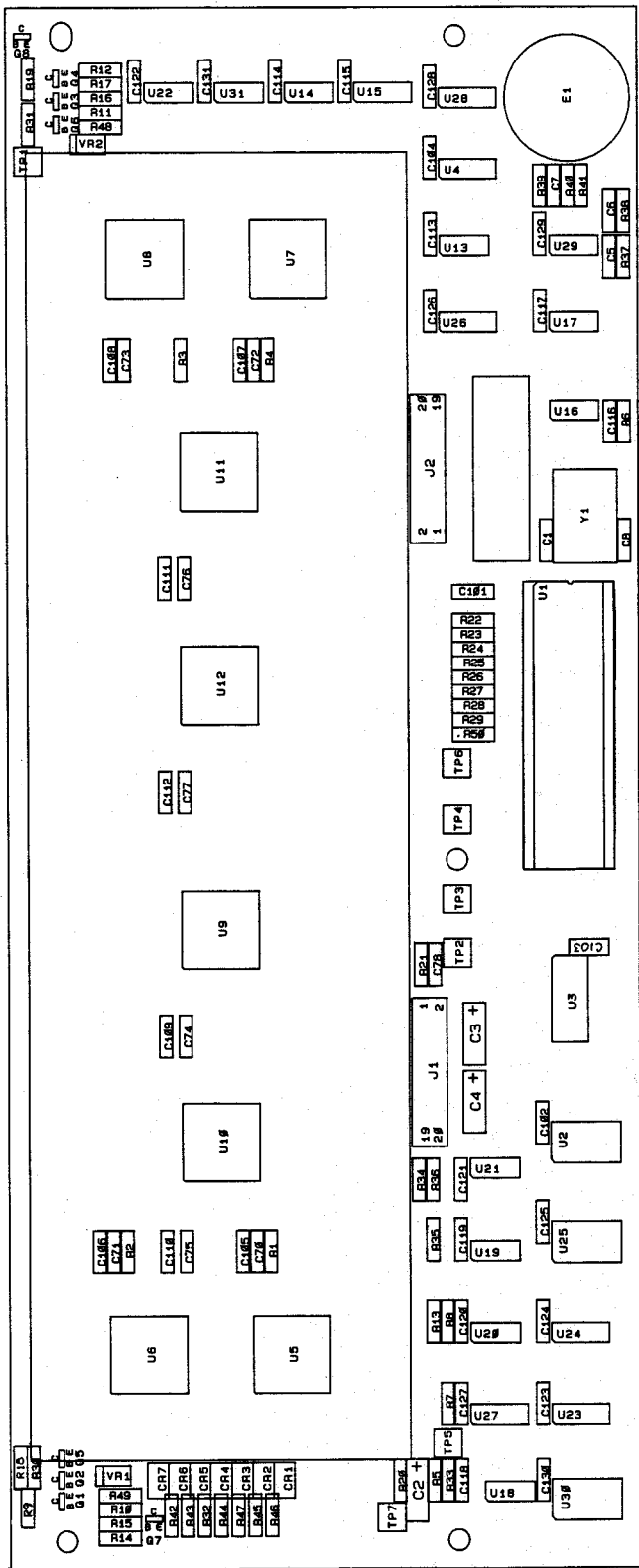

9100A-1602

NOTES:
1.
2.

D

C

B

A

RES +
TRANSE
RECE
F
COLU
EA
RUM-
DIBK-
EA
2X11

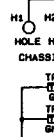

NOTES: UNLESS OTHERWISE SPECIFIED:
 1. ALL RESISTORS VALUES ARE IN OHMS, 1/8W, 5%
 2. ALL CAPACITORS VALUES ARE IN MICROFARADS.

WARNING: ⚡ INDICATES USAGE OF MOS DEVICE(S)
 WHICH MAY BE DAMAGED BY STATIC DISCHARGE. USE SPECIAL
 HANDLING PER S.O.P. 19.1

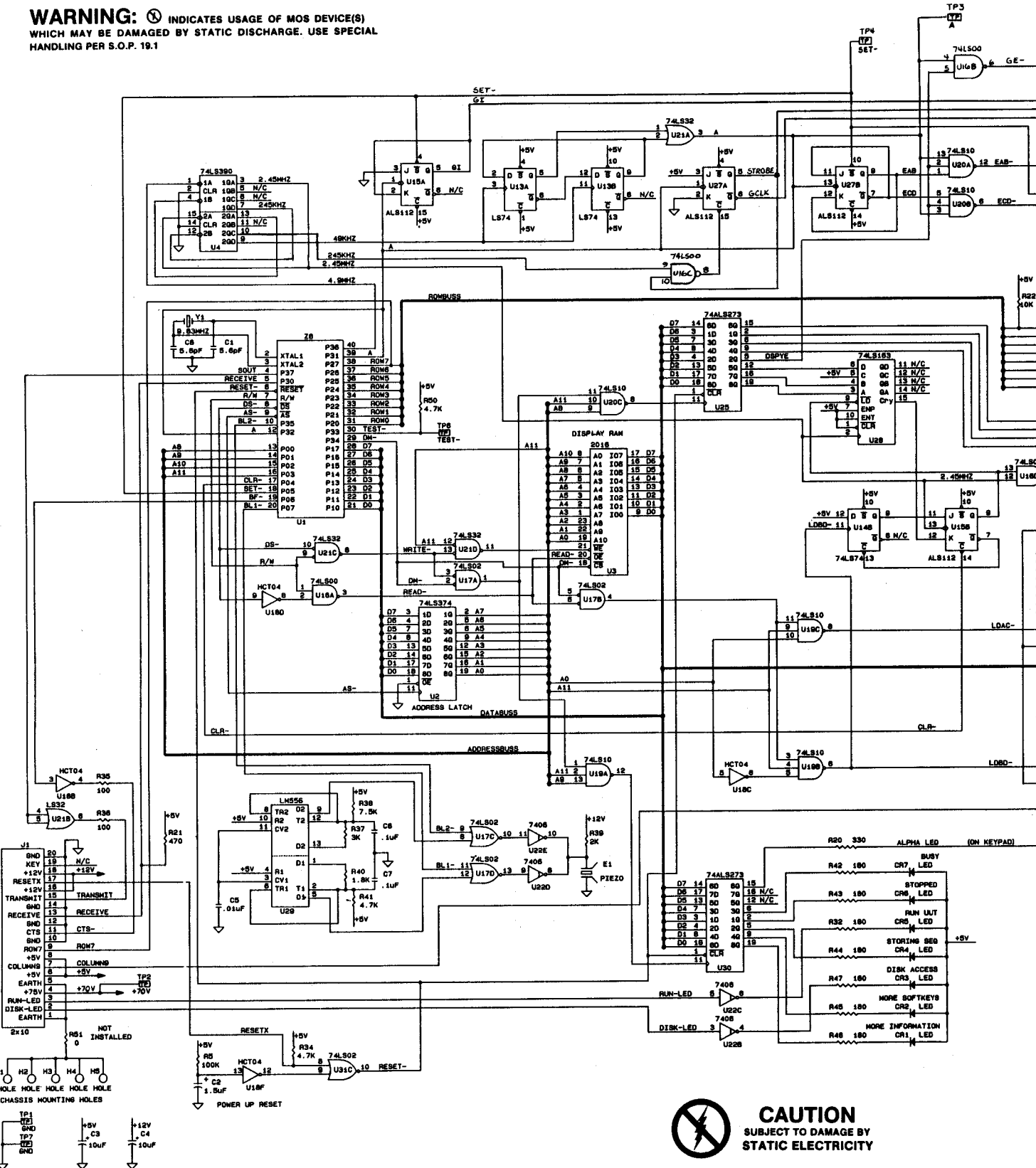

CAUTION
 SUBJECT TO DAMAGE BY
 STATIC ELECTRICITY

8

7

6

5

4

D

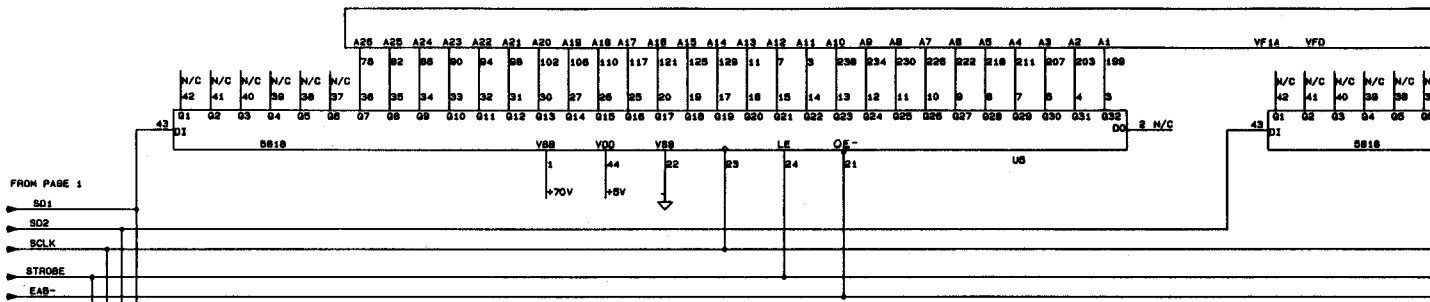

C

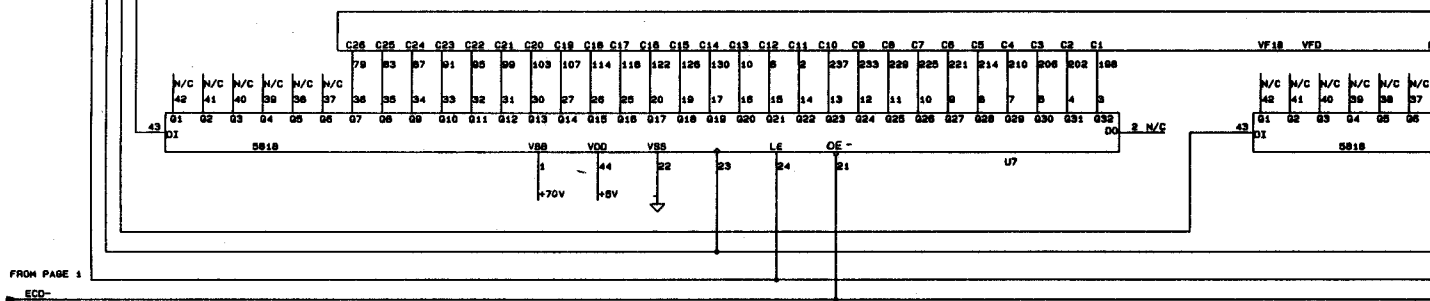

B

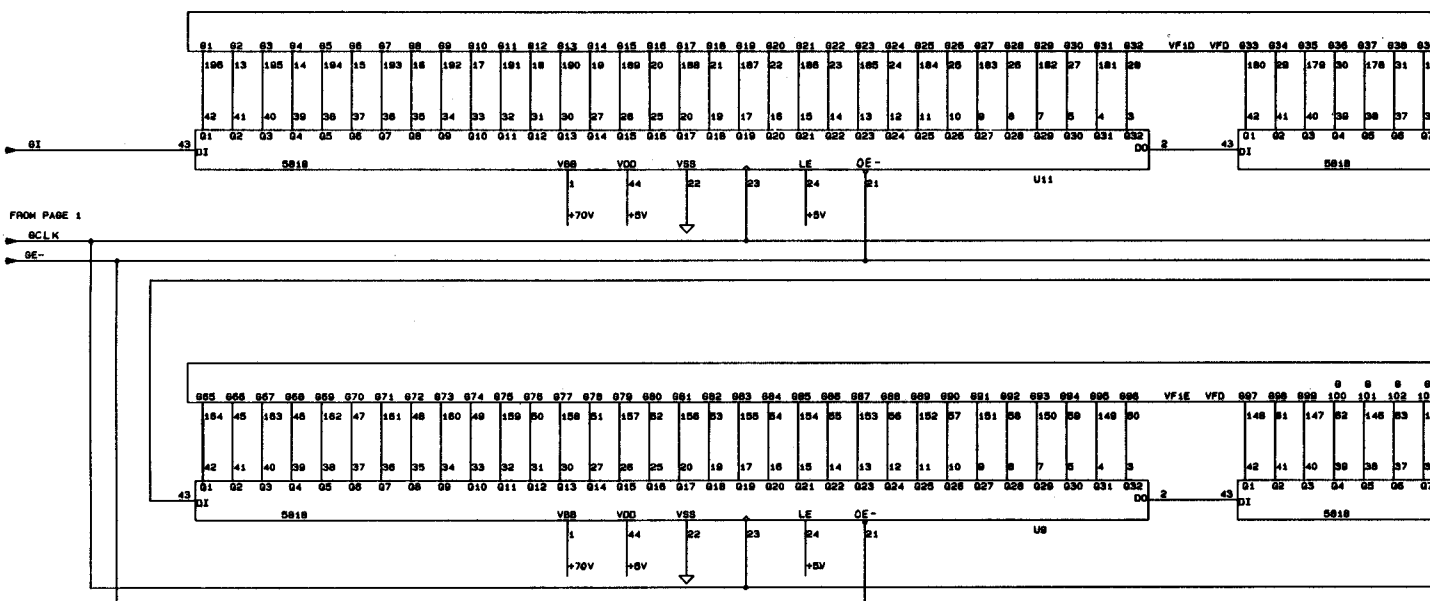

A

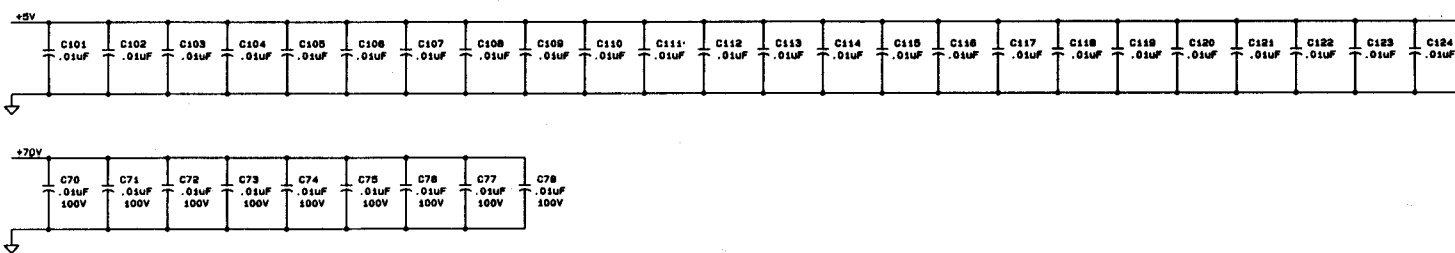

8

7

6

5

4

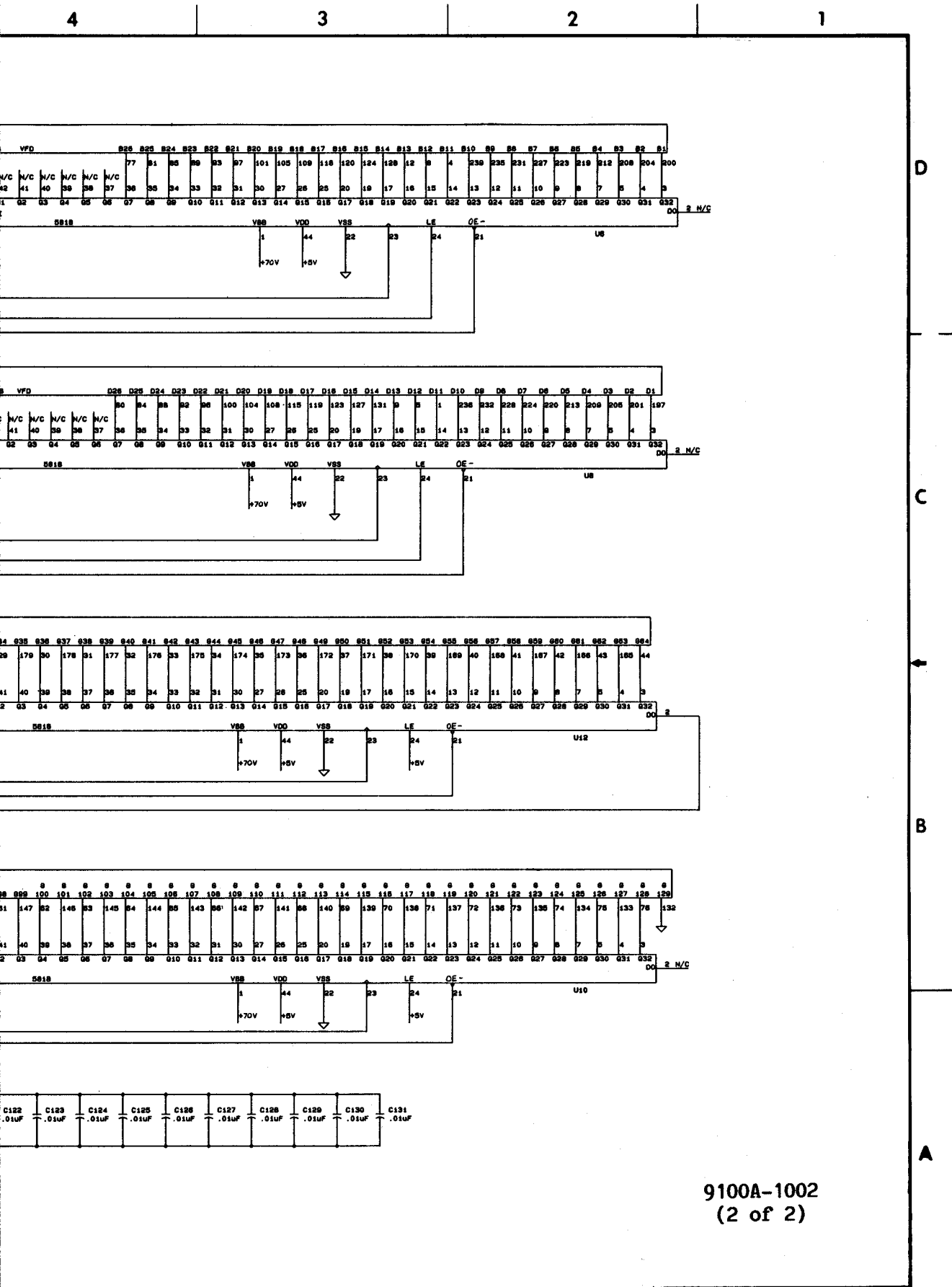

9100A-1002
(2 of 2)

Figure 7-2. A2 Display Interface PCA (cont.)

8

7

6

5

4

D

C

B

A

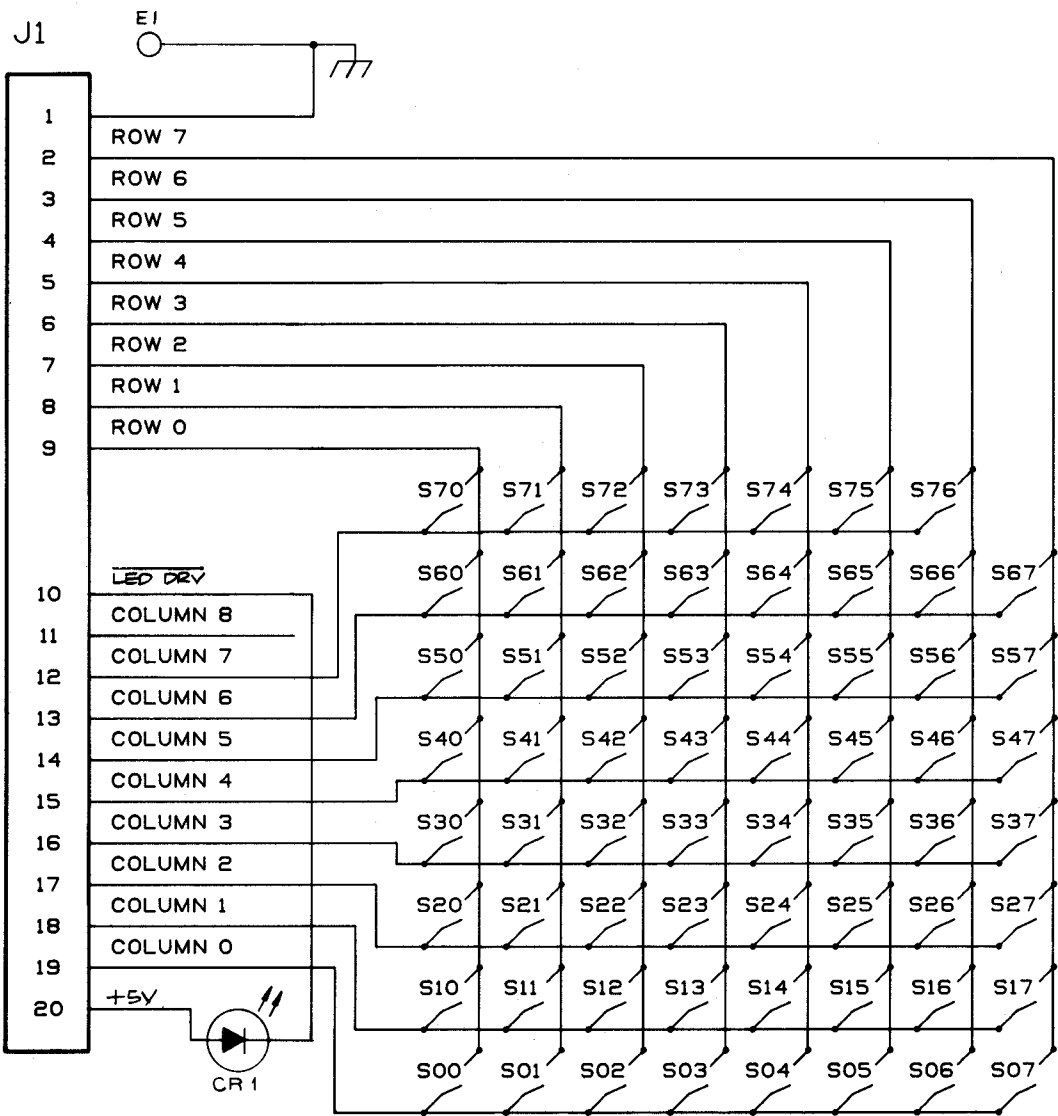

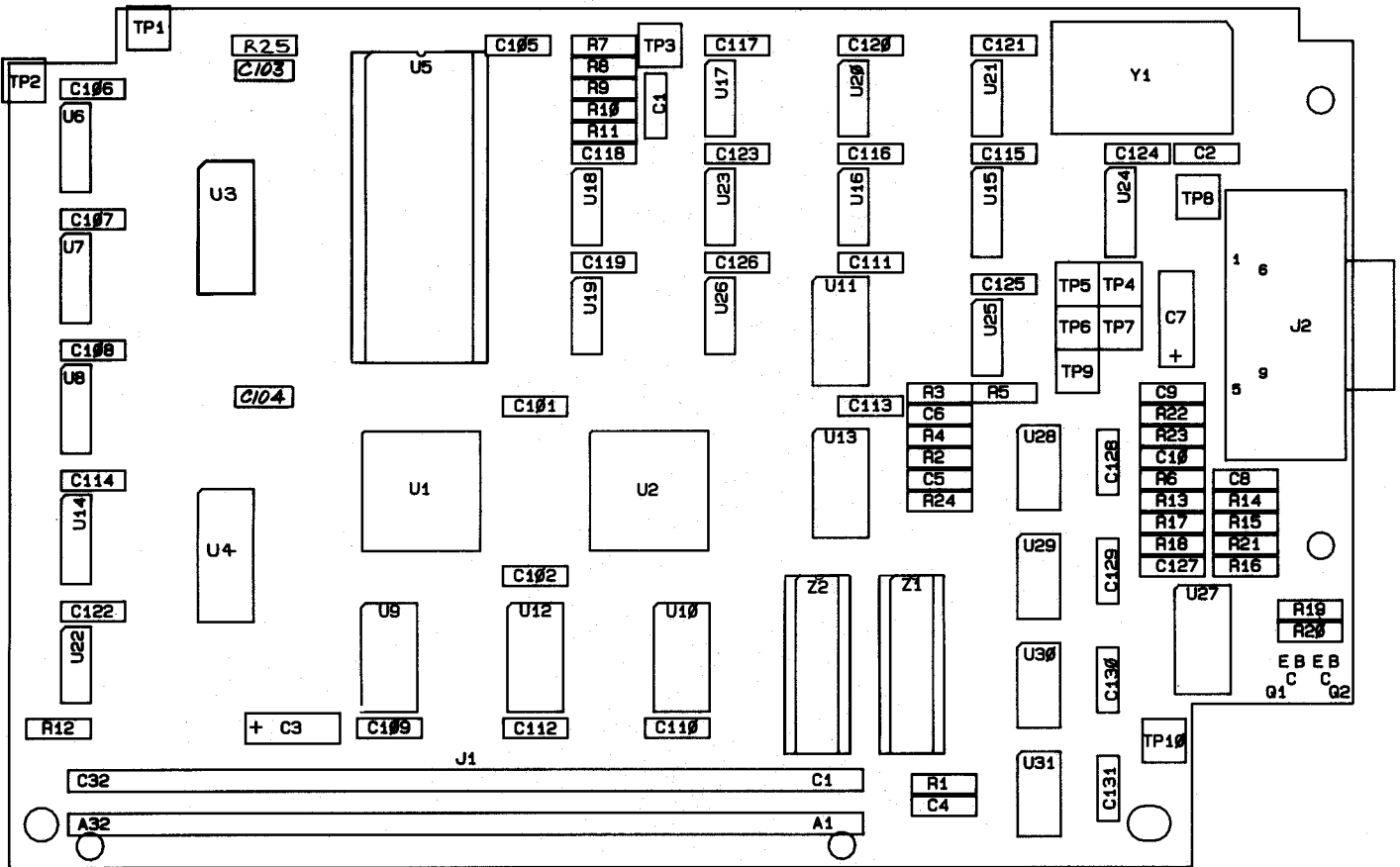

9100A-1604

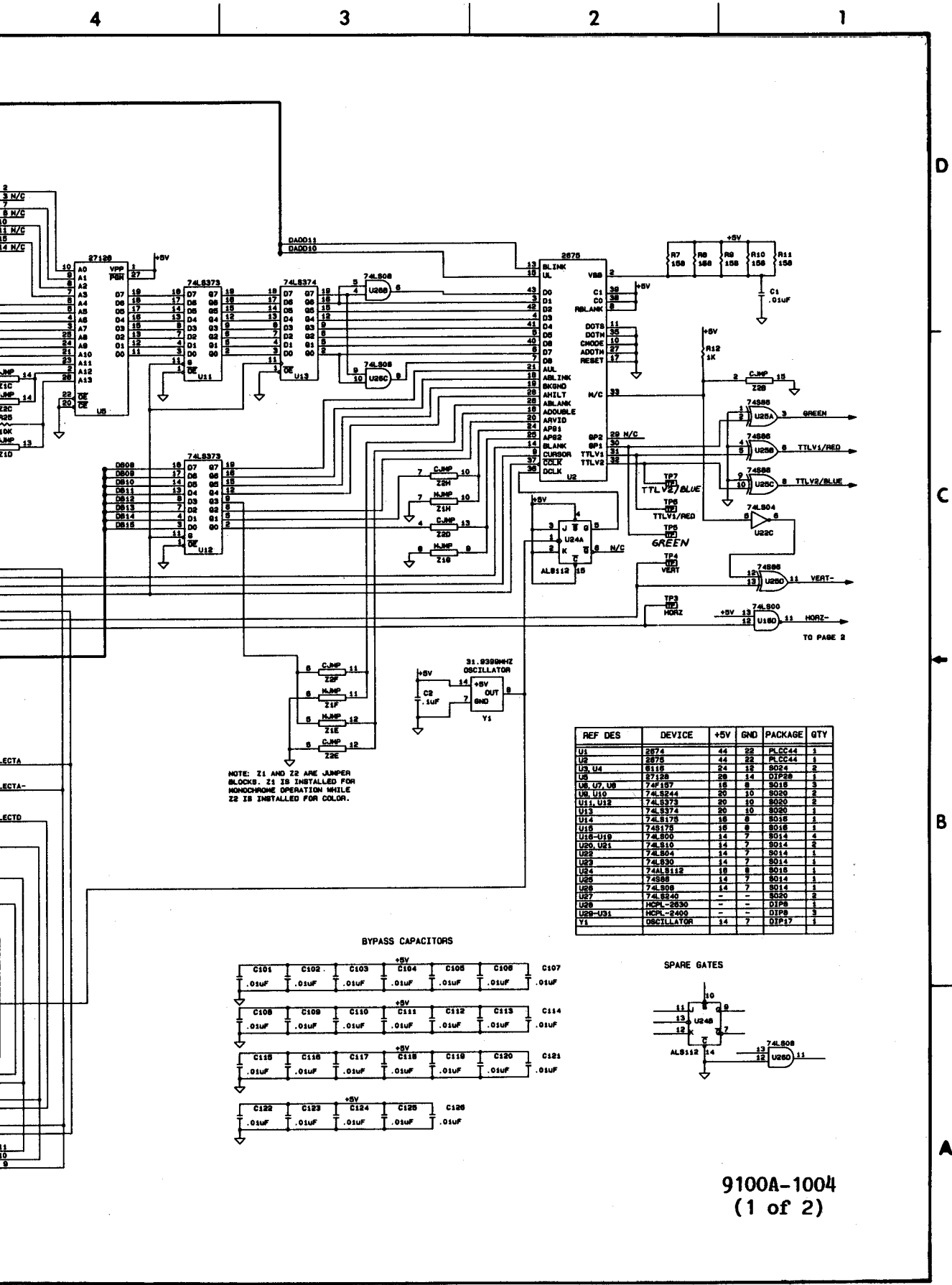

NOTE: Z1 AND Z2 ARE JUMPER BLOCKS. Z1 IS INSTALLED FOR MONOCHROME OPERATION WHILE Z2 IS INSTALLED FOR COLOR.

REF DES	DEVICE	+5V	GND	PACKAGE	QTY
U1	2874	44	22	PLCC44	1
U2	2876	44	22	PLCC44	1
U3, U4	6118	24	12	BD24	2
U5	87128	28	14	DIP28	1
U6, U7, U8	74F197	16	8	SO16	3
U9, U10	74LS244	20	10	SO20	2
U11, U12	74LS373	20	10	SO20	2
U13	74LS374	20	10	SO20	1
U14	74LS175	16	8	SO16	1
U15	74LS176	16	8	SO16	1
U16-U19	74LS00	14	7	SO14	4
U20, U21	74LS10	14	7	SO14	2
U22	74LS04	14	7	SO14	1
U23	74LS30	14	7	SO14	1
U24	74ALS112	16	8	SO16	1
U25	74S88	14	7	SO14	1
U26	74LS08	14	7	SO14	1
U27	74LS240	-	-	SO20	2
U28	MCPL-2630	-	-	DIP8	1
U29-U31	MCPL-2400	-	-	DIP8	3
Y1	OSCILLATOR	14	7	DIP17	1

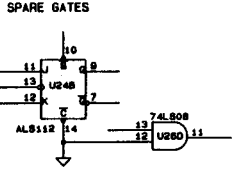
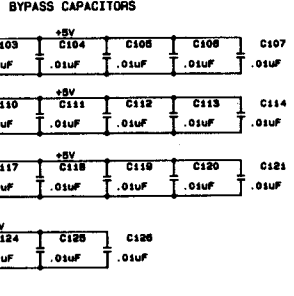

9100A-1004
(1 of 2)

D

C

B

A

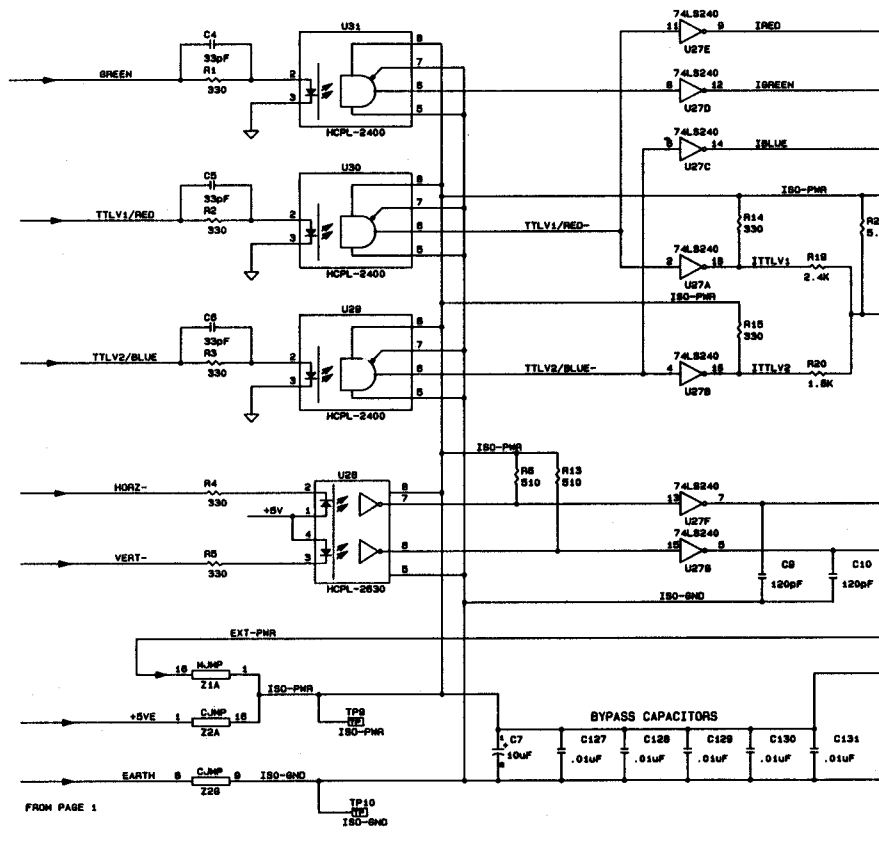

FROM PAGE 1

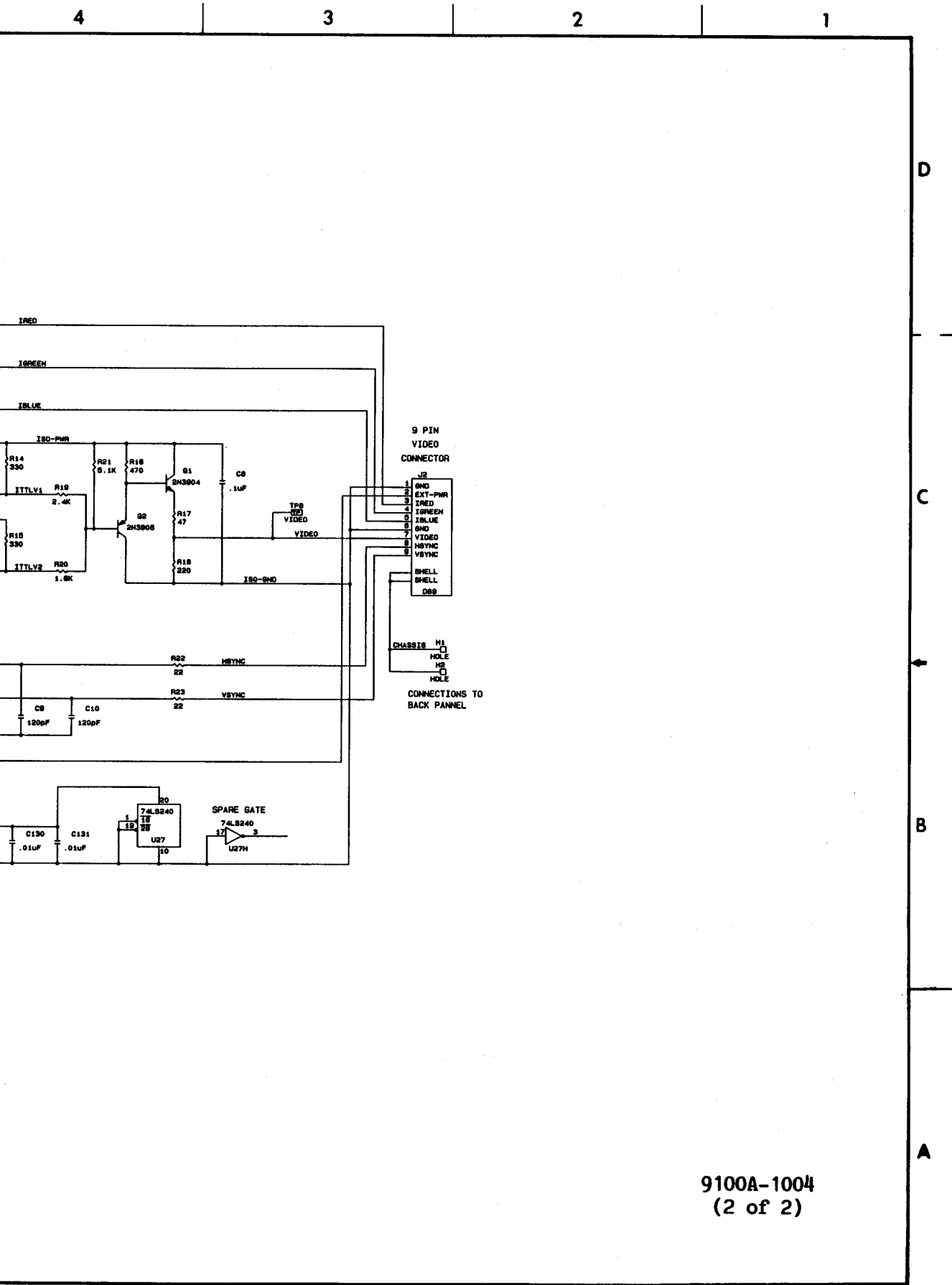

9100A-1004
(2 of 2)

Figure 7-4. A4 Video Controller PCA (cont.)

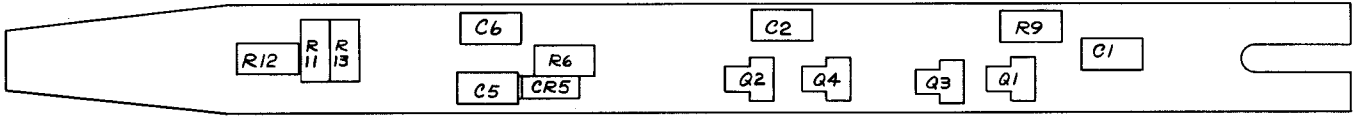

CKT 1

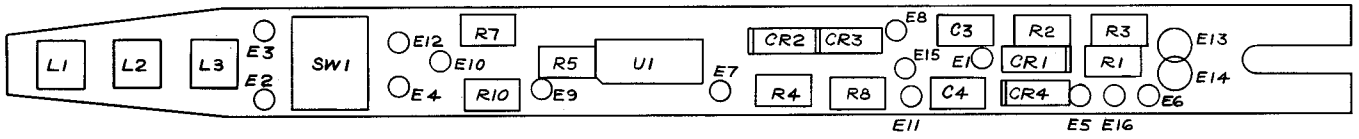

CKT 2

9100A-1605

8

7

6

5

4

D

RED J1-12 E1 +5V

VIOLET J1-7 E2 RED*

BLACK J1-5 E3 YELLOW*

BROWN J1-4 E4 GREEN*

WHITE/RED J1-9 E5 FUSED GND

WHITE J1-14 E6 PROBE TIP

C

GREEN J1-10 E8

BLUE J1-15 E7

ORANGE J1-3 E9 PULSE HI

B

WHITE/BLACK J1-2 E10 PULSE LO

A

YELLOW J1-13 E11 -1.2V

GRAY J1-8 E12 SWITCH*

WHITE/GREEN J1-1 E13 EARTH-GND

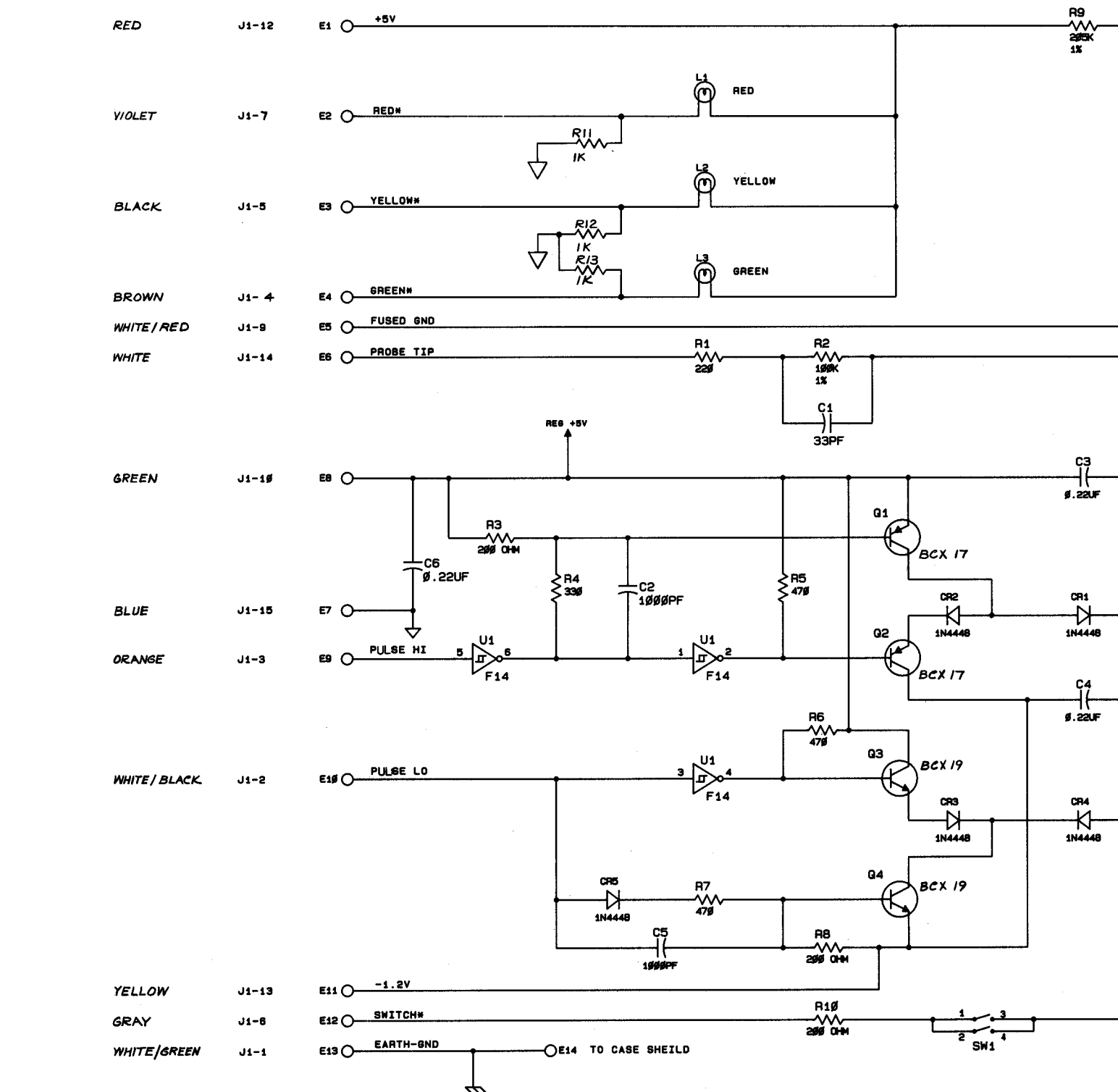

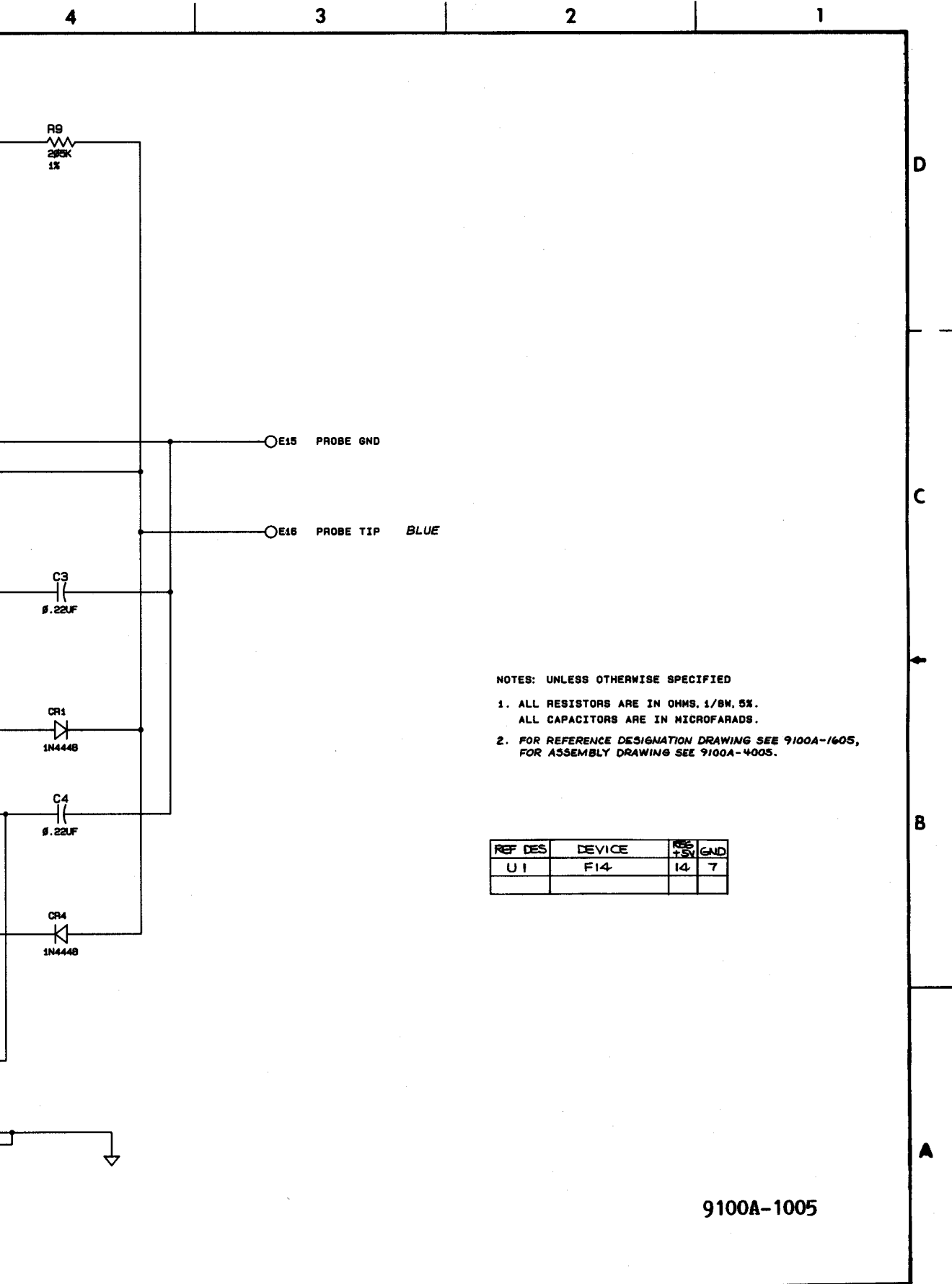
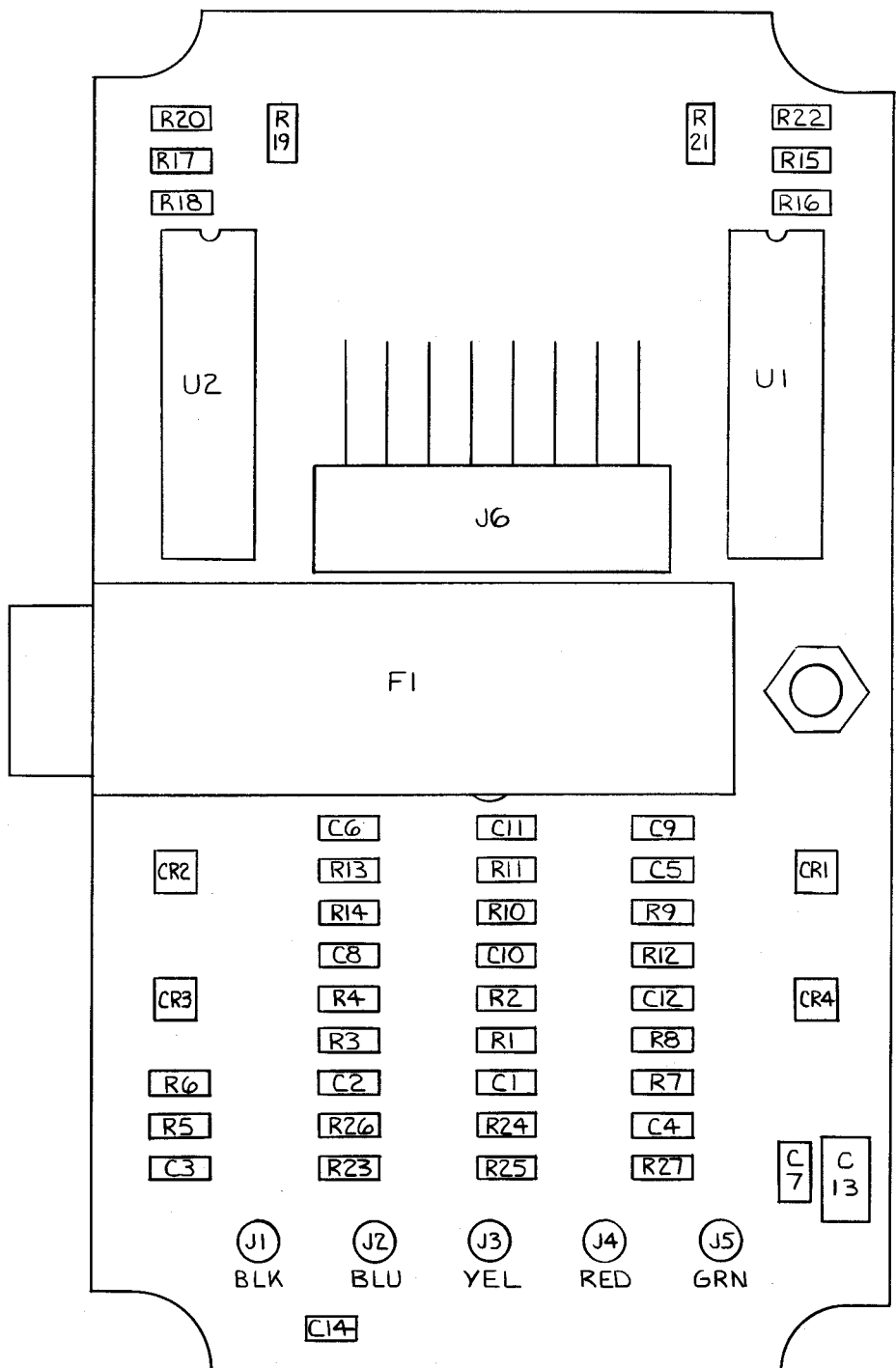

Figure 7-5. A5 Probe PCA



9100A-1606

8

7

6

5

4

D

C

B

A

STOP
(RED)

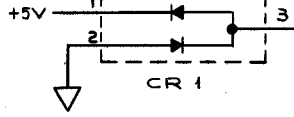
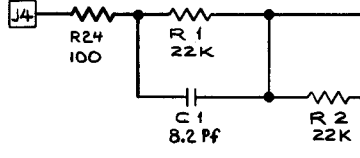

CLOCK
(YEL)

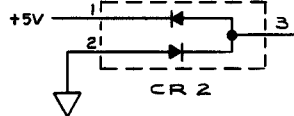
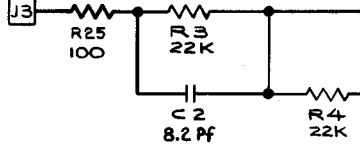

ENABLE
(BLU)

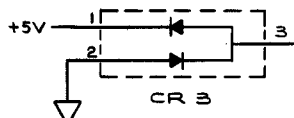
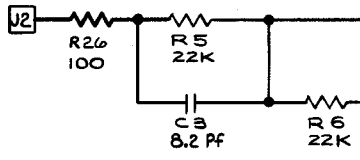

START
(GRN)

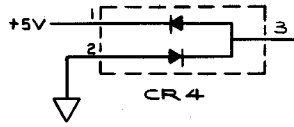
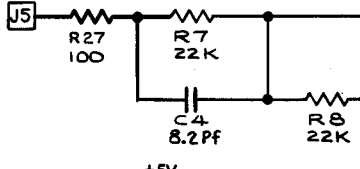

GND
(BLK)

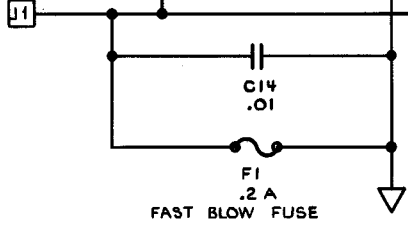

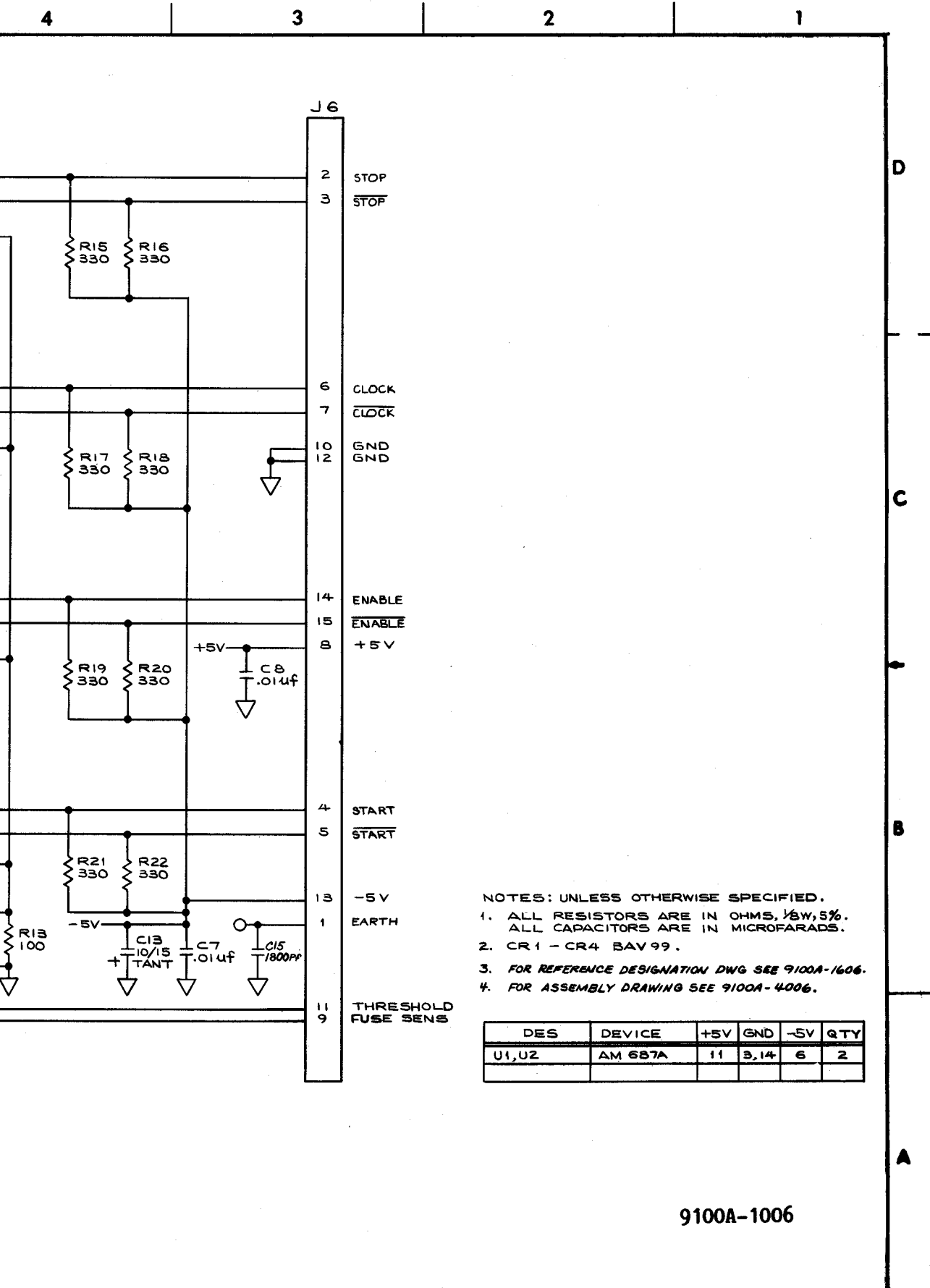

- NOTES: UNLESS OTHERWISE SPECIFIED.
1. ALL RESISTORS ARE IN OHMS, 1/8W, 5%.
 2. ALL CAPACITORS ARE IN MICROFARADS.
 3. CR 1 - CR 4 BAV 99.
 4. FOR REFERENCE DESIGNATION DWG SEE 9100A-1606.
 5. FOR ASSEMBLY DRAWING SEE 9100A-4006.

DES	DEVICE	+5V	GND	-5V	QTY
U1,U2	AM 687A	11	3,14	6	2

9100A-1006

Figure 7-6. A6 Clock Module PCA

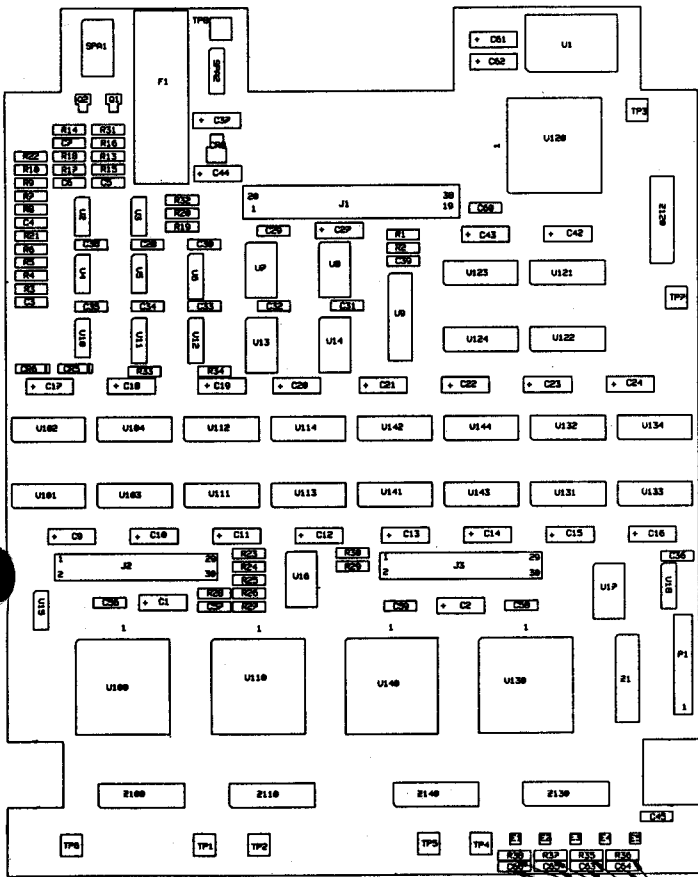

CKT 8

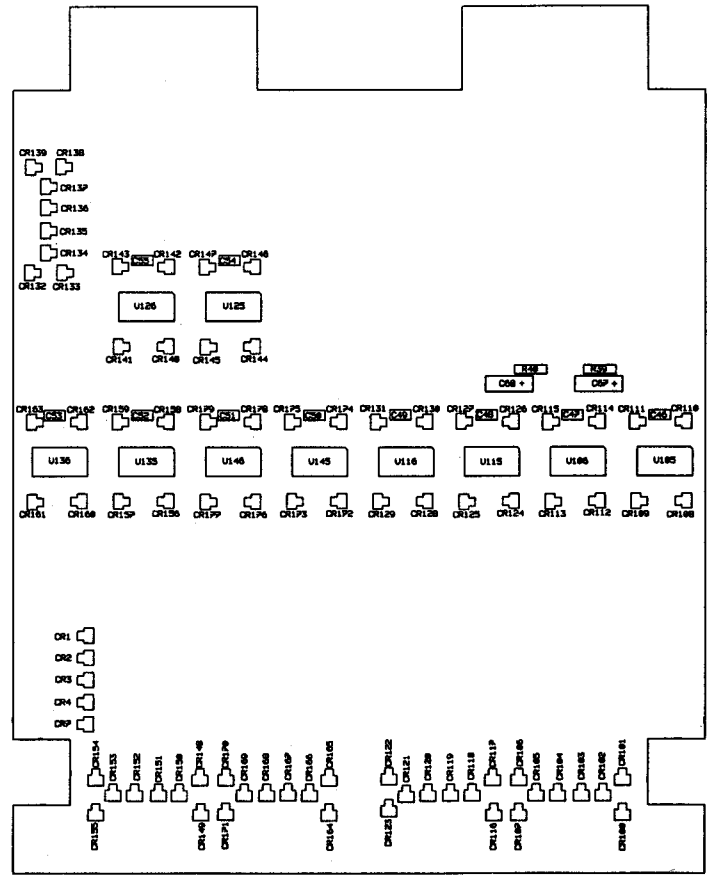

CKT 1

NOT INSTALLED

9100A-1607

NOTES: UN
1. ALL RA
2. ALL CA

WA
WHICH
HANDL

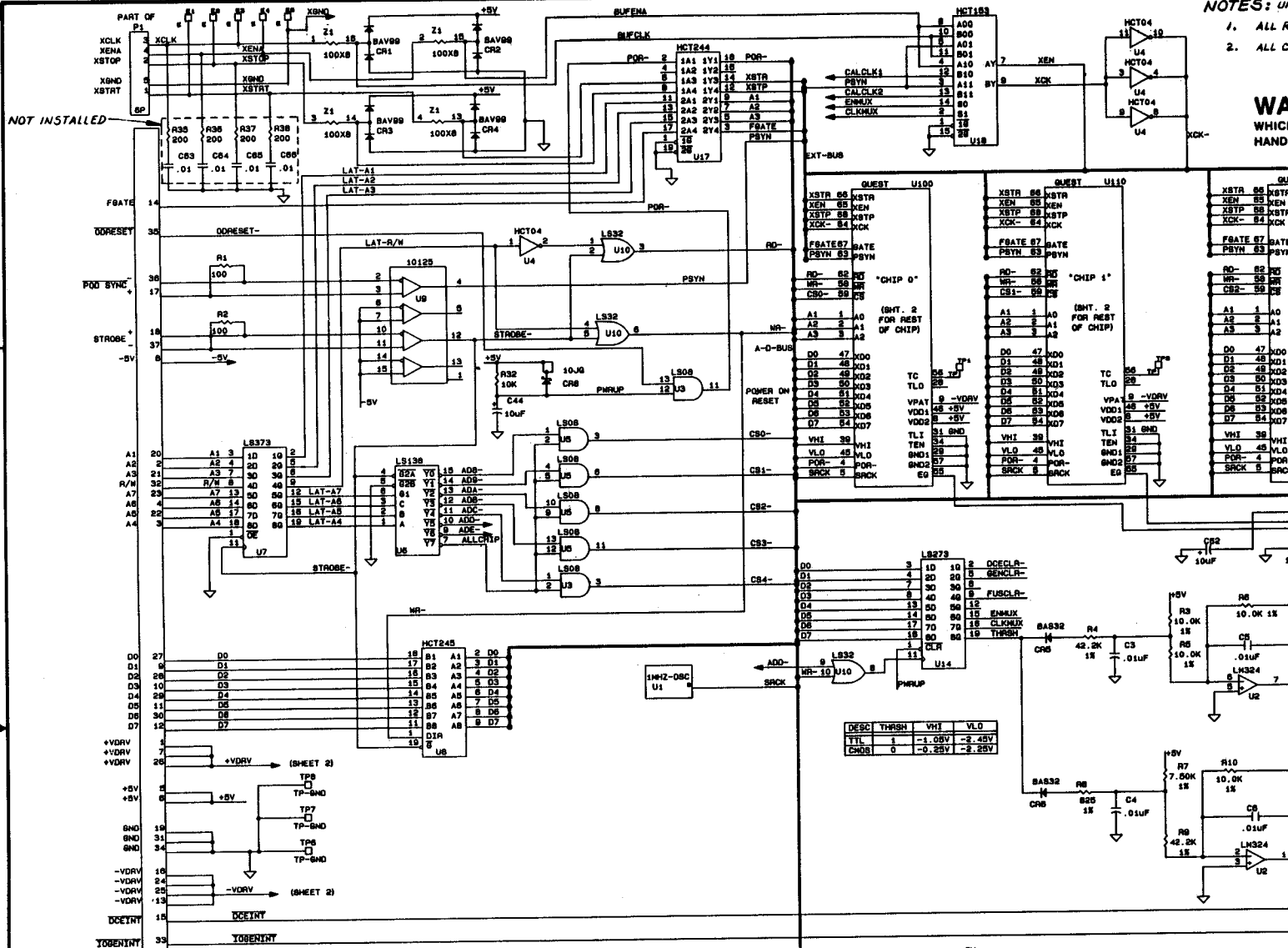

DESC	THRESH	VHI	VLO
TYL	1	-3.0V	-2.5V
CMGR	0	-0.25V	-2.5V

ADDRESS DECODING
MODULE SEL ON CHIP REGISTERS

ADDR	READ	WRITE
B	READ FROM CHIPS	WRITE TO CHIPS
A		
C		
D	READ INTPTP RES	WRITE CONTROL
E	READ CONNECT CODE	NOT DECODED
F	ALL CHIPS - ALIAS	WRITE ALL CHIPS

BIT	DESCRIPTION
7	THRESHOLD STATUS
6	CLK MIX STATUS
5	ENABLE MIX STATUS
4	GROUND (0)
3	FUSE BLOWN
2	PUSH BUTTON (RIGHT)
1	PUSH BUTTON (LEFT)
0	DCE (DATA COMPARE EQUAL)

BIT	DESCRIPTION
7	THRESHOLD (1=TYL)
6	CLK MIX (0=XCLK)
5	ENABLE MIX (0=EXTENA)
4	NOT USED
3	CLR FUSE BLOWN (0=CLR)
2	NOT USED
1	CLR GEN INTPTP (0=CLR)
0	CLR DCE INTPTP (0=CLR)

DES	LAST USED	NOT USED
P	P1	
J	J3	
Q	Q2	
U	U146	U29-99, 101-104, 107-109, 117-119, 127-129, 137-139
R	R38	R11, 12
C	C66	C8, 25, 26, 40, 41
CR	CR179	CR9-99
E	E5	
TP	TP8	
Z	Z140	Z2-99, 101-109, 111-119, 121-129, 131-139
F	F1	

CLKMUX	ENAMUX	XEN	XCLK
0	0	0	BUFCLK-
0	1	0	BUFCLK-
1	0	0	CALCLK1
1	1	0	PSYN



CAUTION
SUBJECT TO DAMAGE BY
STATIC ELECTRICITY

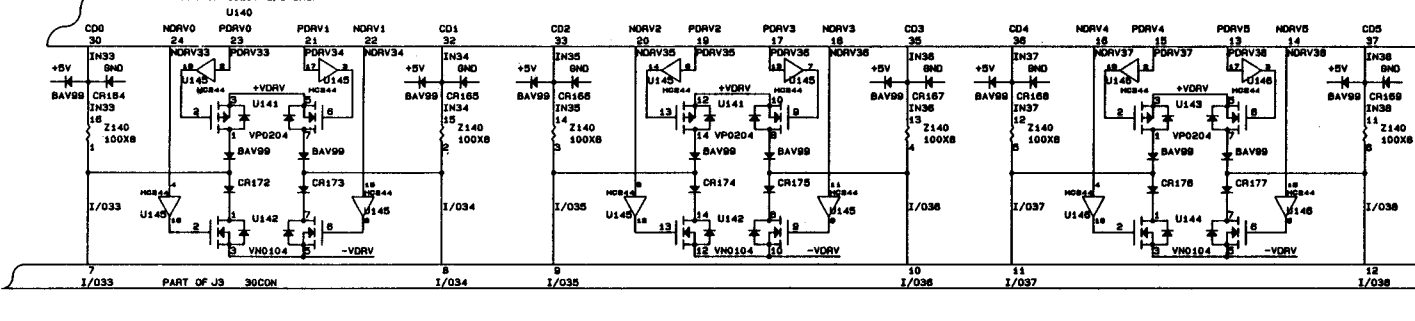
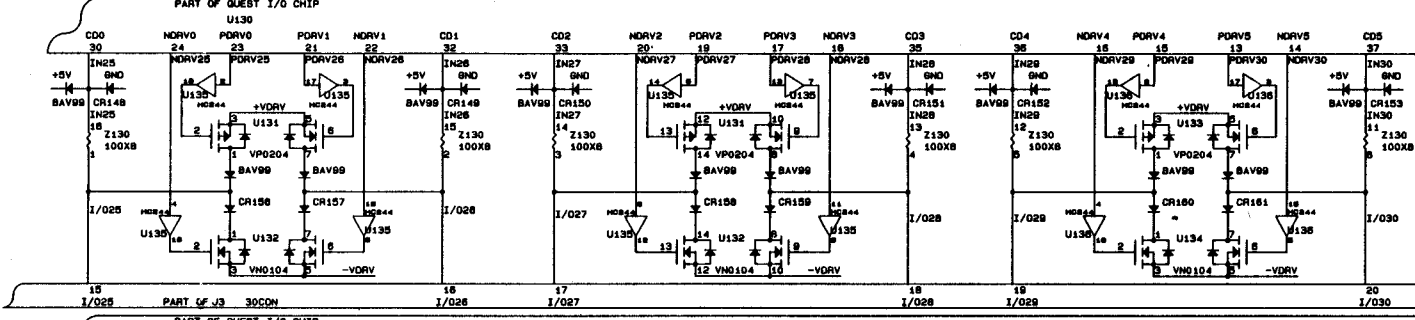
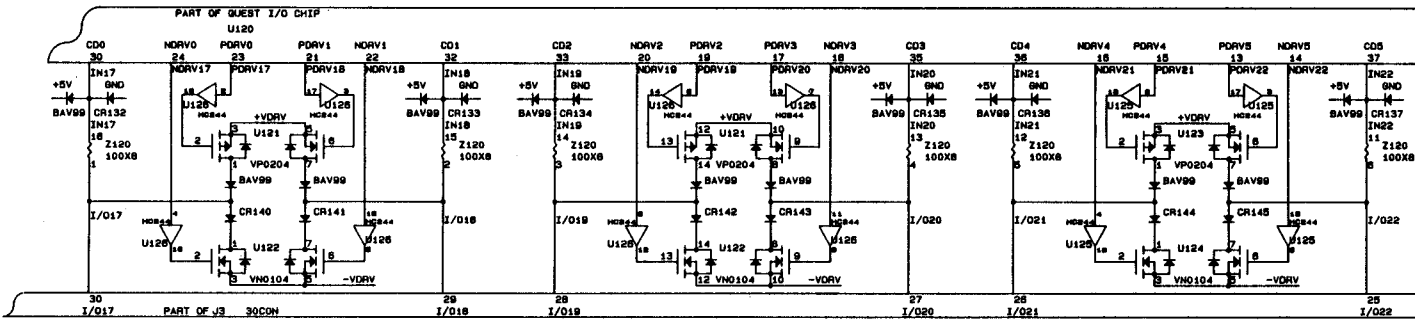
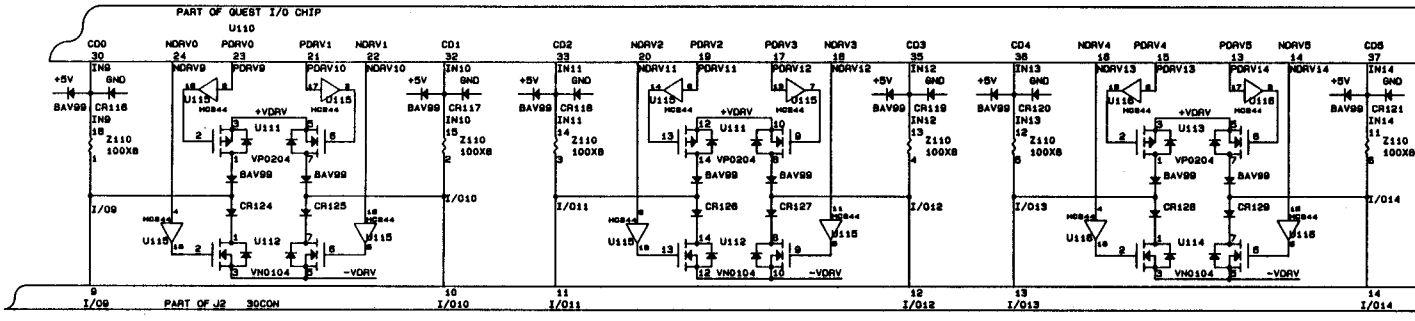
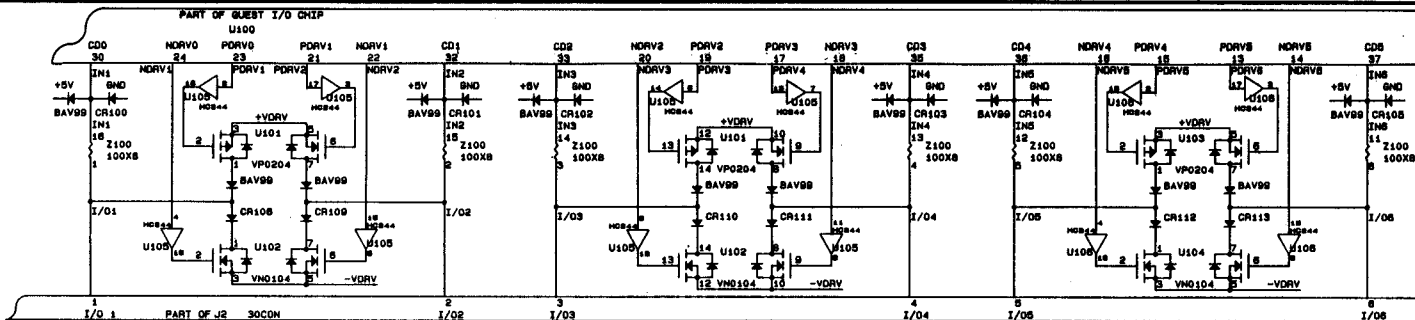

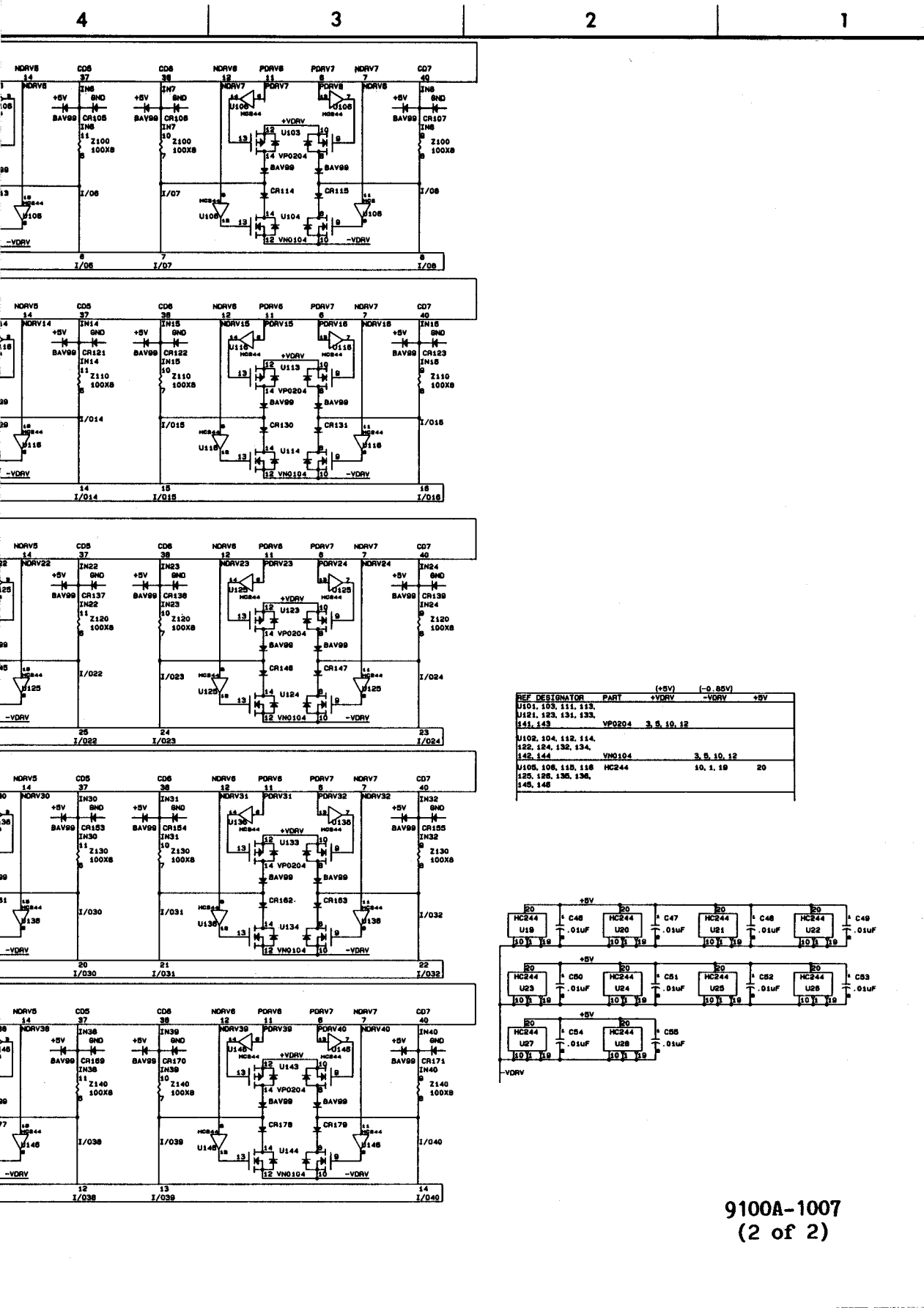

REF	DESIGNATOR	PART	(+5V)	(-0.85V)	+5V
			+VDRV	-VDRV	
U101, 103, 111, 113					
U121, 123, 131, 133,					
141, 143		VP0204	3, 5, 10, 12		
U102, 104, 112, 114,					
122, 124, 132, 134,					
142, 144		VM0104	3, 5, 10, 12		
U106, 108, 116, 118		HC244	10, 1, 18	20	
125, 126, 135, 136,					
145, 146					

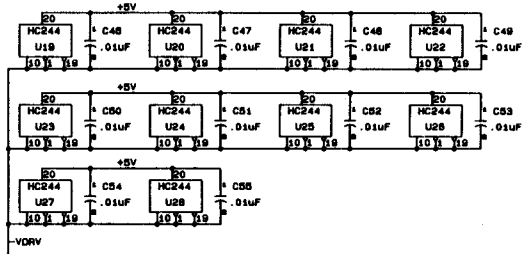

9100A-1007
(2 of 2)

Figure 7-7. A7 I/O Module (Main) PCA (cont.)

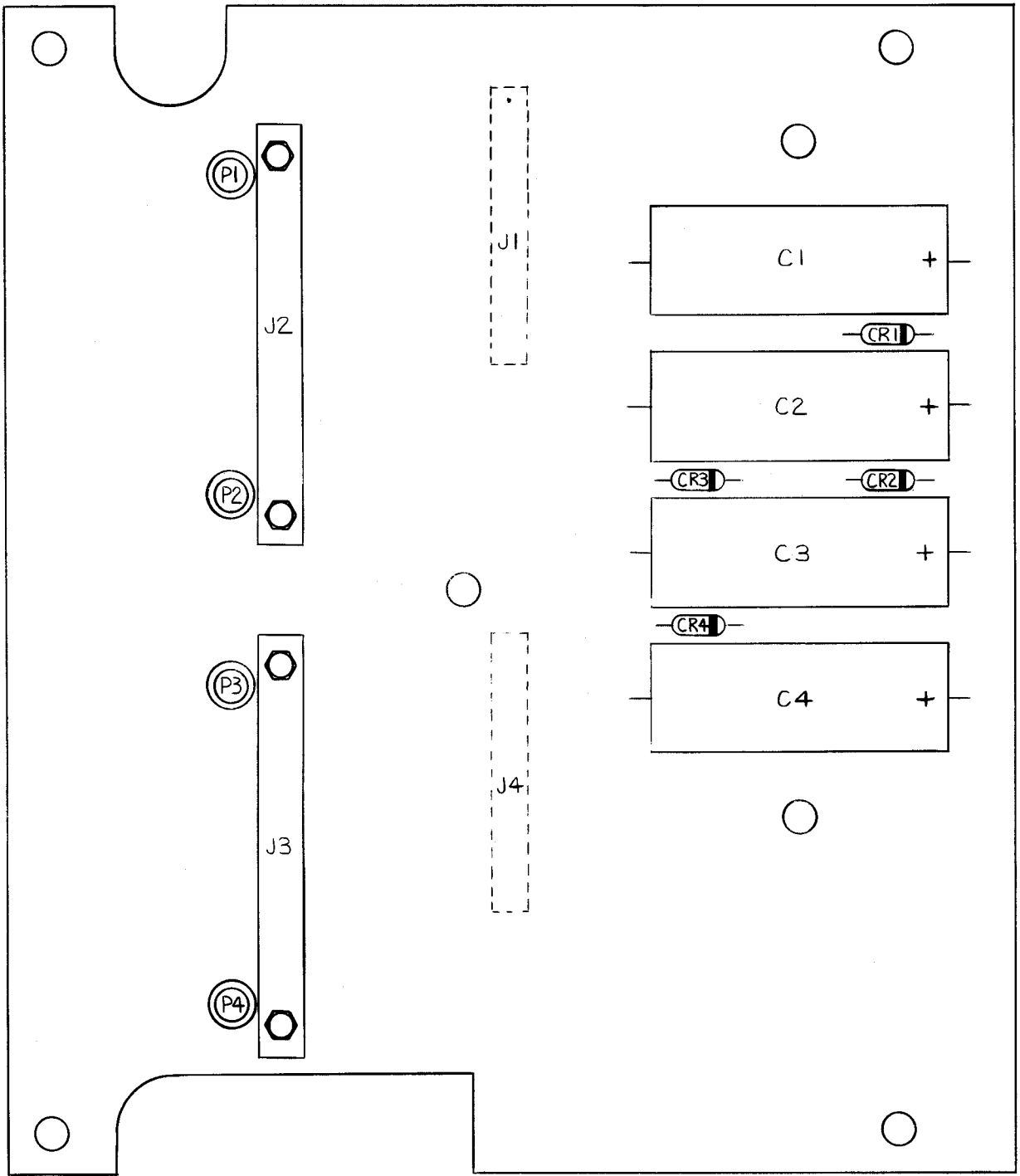

9100A-1608

D

C

B

A

J1 AND J4 GO TO THE MAIN IONOD PCBBOARD

J2 AND J3 CONNECT TO THE CLIP MODULES

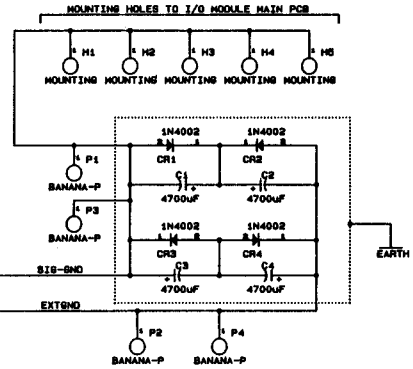
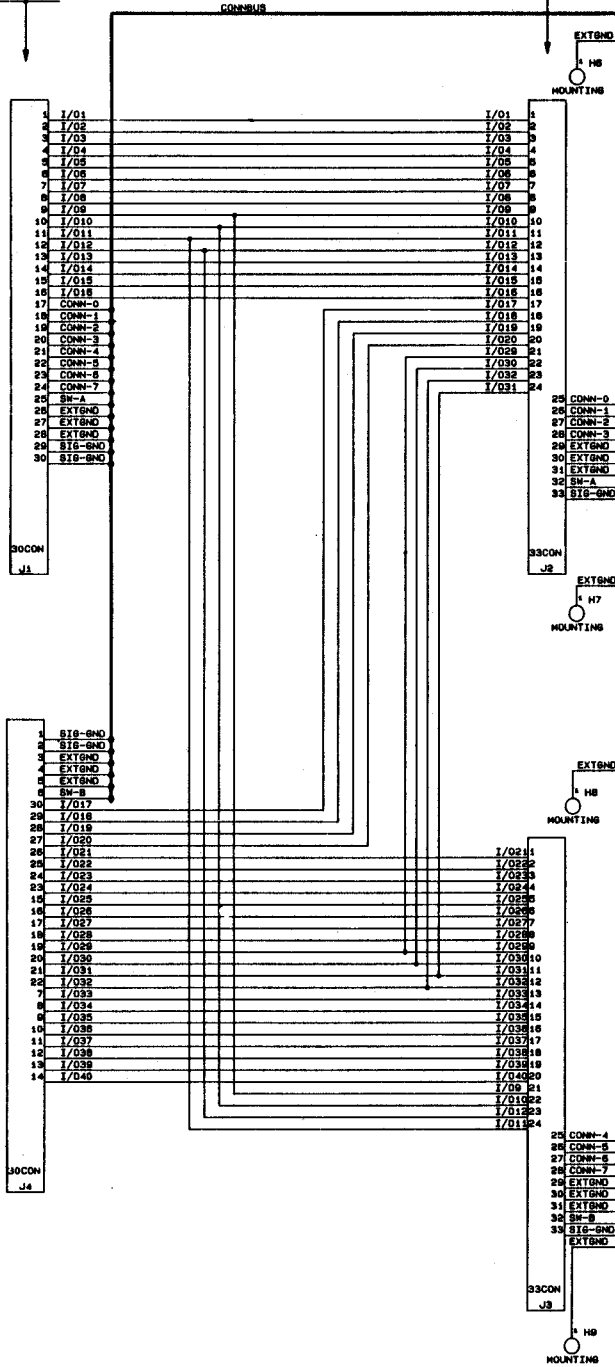

4

3

2

1

D

NOTES: UNLESS OTHERWISE SPECIFIED.

1. PCB TO BE FOUR LAYER, WITH 2 GROUND PLANES: SIG-GRD, AND EXTEND.
2. ALL OF THE 'I/O' SIGNALS SHOULD HAVE TRACES AS WIDE AS POSSIBLE: (1.030 MINIMUM).
3. THE 4 DIODES SHOULD BE NEAR THE CAPACITORS, SO THEY ARE UNDER THE SHIELD "CAN".
4. ALL CAPACITOR VALUES ARE IN MICROFARADS.

C

B

A

DES	LAST USED	NOT USED
J	J4	—
P	P4	—
CR	CR4	—
C	C4	—

9100A-1008

Figure 7-8. A8 I/O Module (Top) PCA

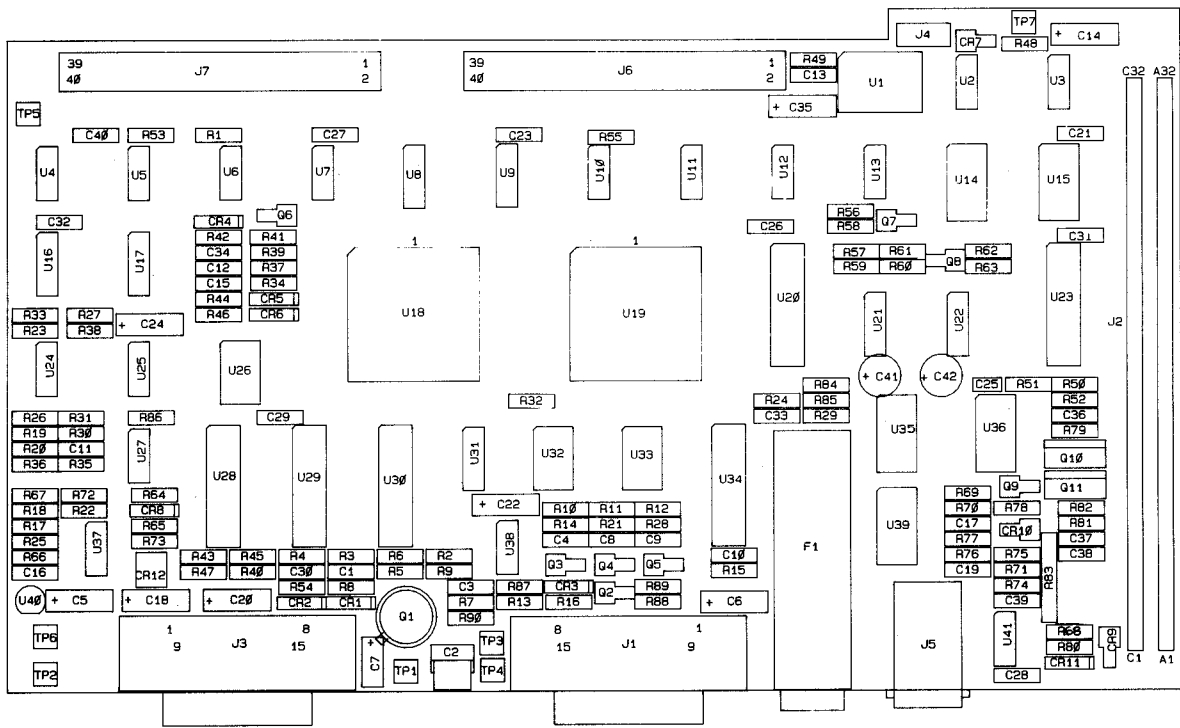

9100A-1609

8

7

6

5

4

D

C

B

A

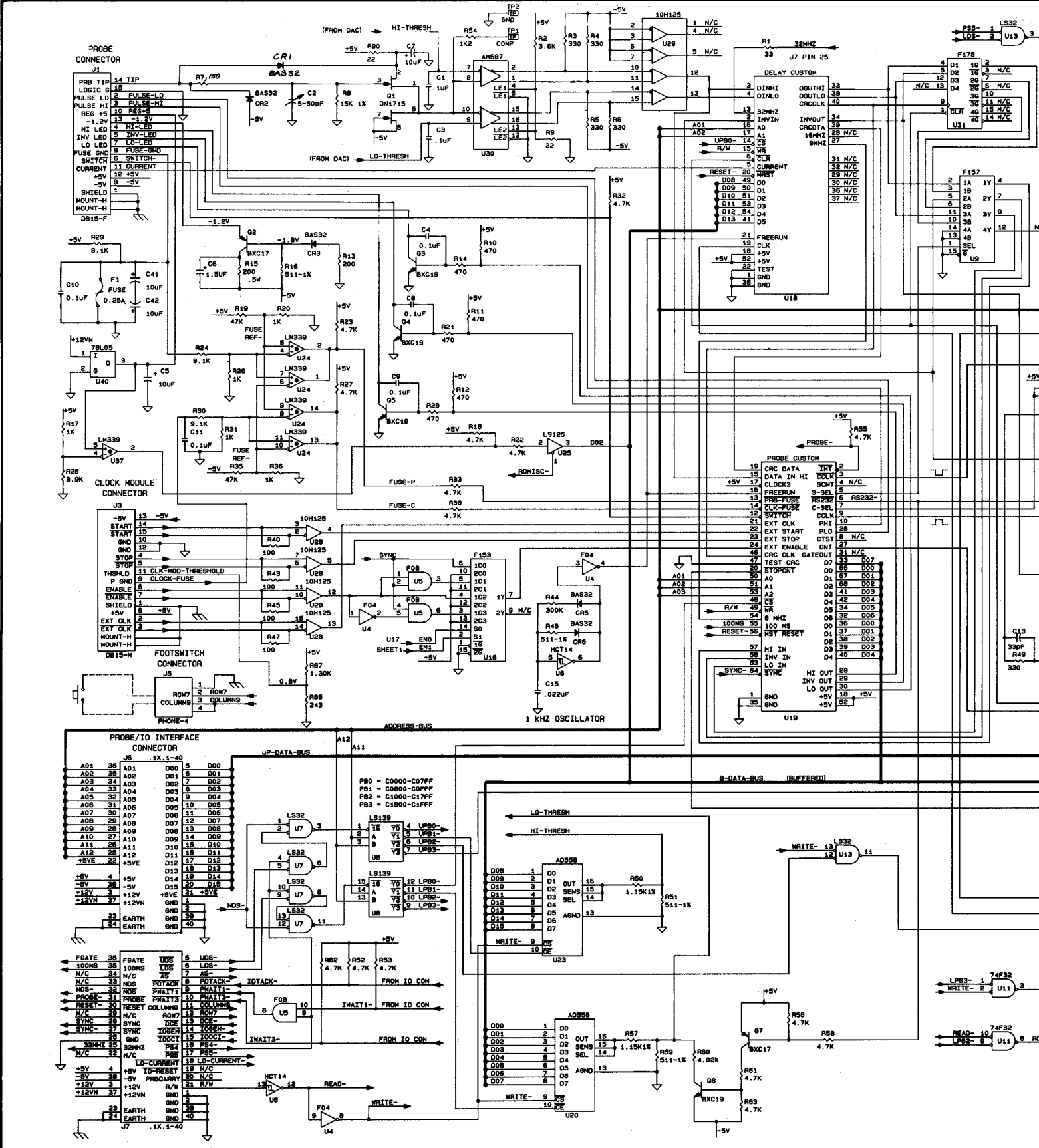

-VDRV REGULATOR FOR
I/O MODULE PATTERN DRIVE
(-0.85V, 2A SHORT TERM,
250MA LONG TERM)

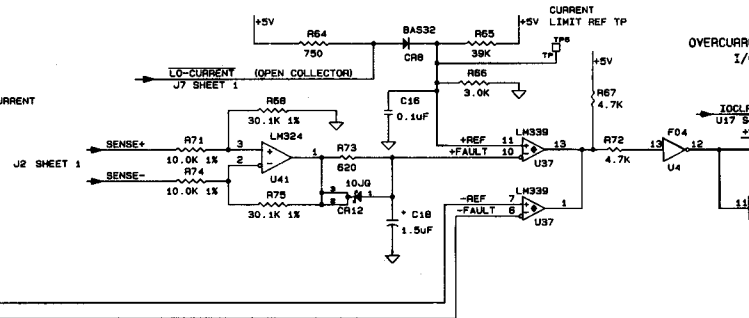
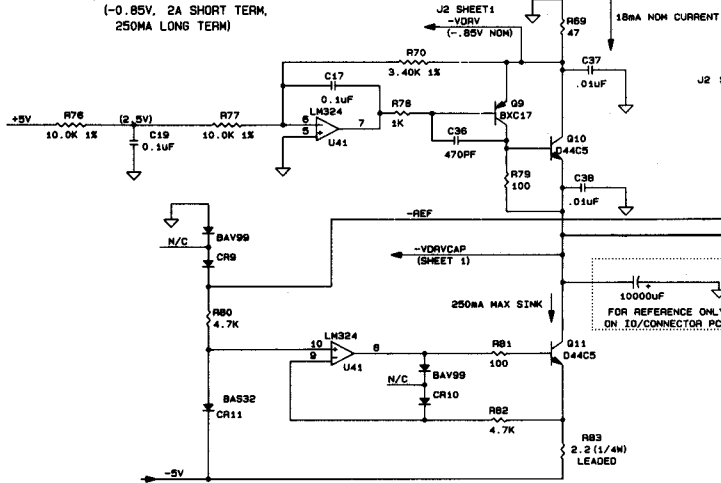

SEE SHEET 1

40 MHZ STOP COUNTER

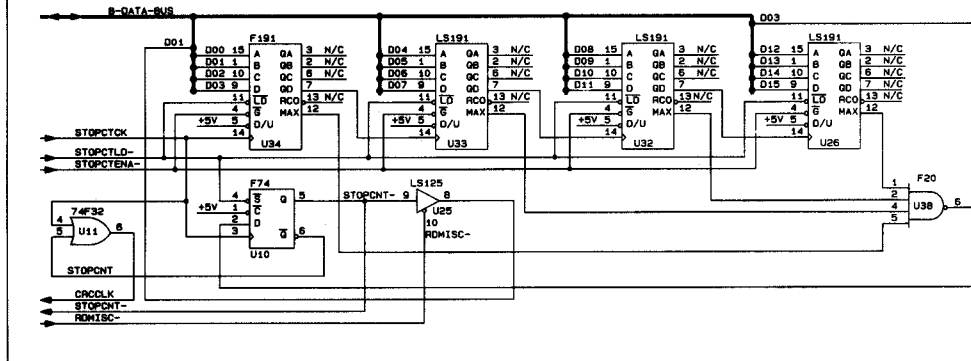

BITS		READ AT C1001
3	1	NO INTERRUPT ACTIVE
3	0	ACTIVE OVERCURRENT INTERRUPT
2	1	SV PULSER POWER AVAILABLE
2	0	SV SHUTDOWN
1	1	STOP COUNTER NOT AT MAX COUNT
1	0	STOP COUNTER AT MAX COUNT
0	1	CARRY BIT SET
0	0	CARRY BIT NOT SET

BITS		WRITE AT C1801
EXTERNAL ENABLE MULTIPLEXER		
0, 0	0	POD SYNC
0, 1	0	POD SYNC QUALIFIED BY ENABLE
1, 0	1	ENABLE
1, 1	1	POD SYNC QUALIFIED BY ENABLE
1	1	CLEAR OVERCURRENT INTERRUPT
0	0	RELEASE OVERCURRENT INTERRUPT
0	1	ENABLE EXTERNAL STOP COUNTER
0	0	DISABLE EXTERNAL STOP COUNTER

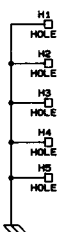
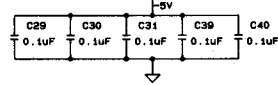
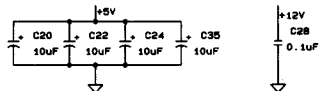
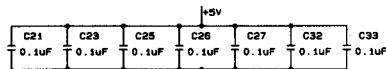

4 3 2 1

OVERCURRENT DETECTION CIRCUITRY FOR I/O MODULE PATTERN DRIVE

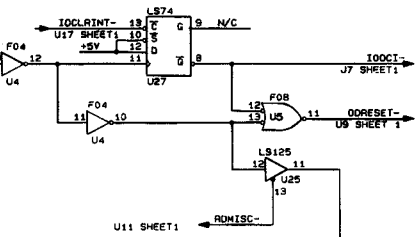

SPARE GATES

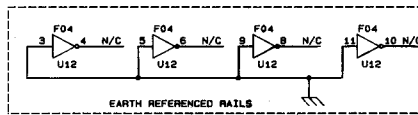
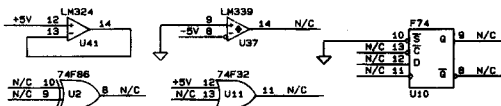

PART	TYPE	+12V	+5V	GND	-5
U1	MCPL-2400		(ISOLATED +5)		
U2	74F86	14	7		
U3	74LS02	14	7		
U4	74F04	14	7		
U5	74F08	14	7		
U6	74HCT14	14	7		
U7, U13	74LS32	14	7		
U8	LS159	16	8		
U9	74F157	16	8		
U10	74F74	14	7		
U11	74F32	14	7		
U12	74F04	(ISOLATED +5)			
U14, U15	74LS244	20	10		
U16	74F153	16	8		
U17	LS175	16	8		
U18	DELAY GATE ARRAY	18, 32	1, 35		
U19	LOGIC GATE ARRAY	18, 52	1, 35		
U20, U23	AD598	11	12		
U21, U22	LS590	16	8		12
U24, U37	LM339	3			
U25	74LS125	14	7		12
U26, 32, 33	LS191	16	8		
U27	LS74	14	7		
U28, U29	LS125	9	16	8	
U30	AM687	11	3, 14	6	
U31	74F175	16	8		
U34	74F191	16	8		
U35, 36, 39	74LS245	20	10		
U38	74F20	14	7		
U40	78L05	1	2		
U41	LM324	4		11	

D
C
B
A

9100A-1009
(2 of 2)

Figure 7-9. A9 Probe I/O PCA (cont.)

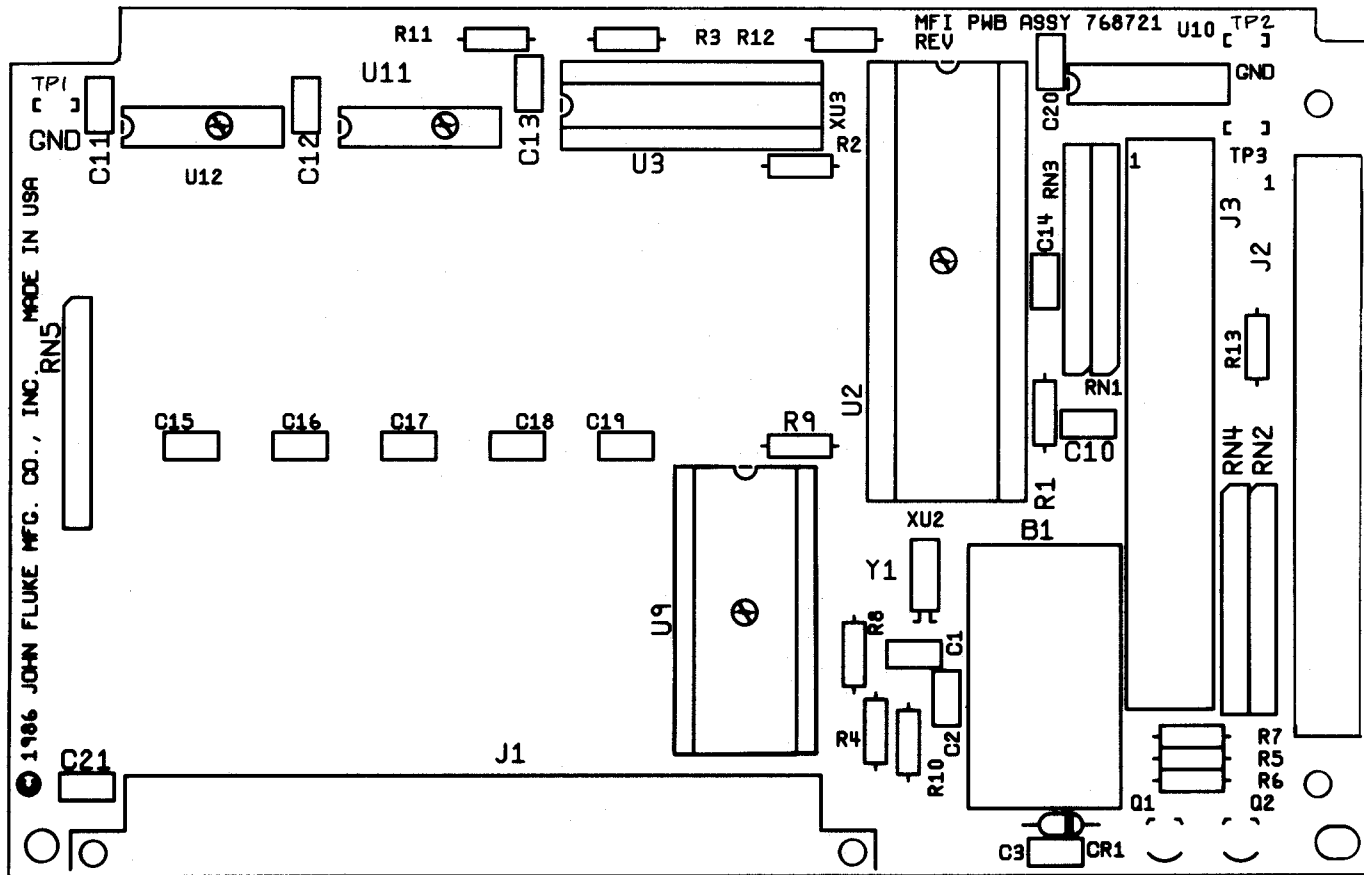

9100A-1610



CAUTION
SUBJECT TO DAMAGE BY
STATIC ELECTRICITY

DES	LAST USED	NOT USED
TP	TP3	---
J	J3	---
U	U12	---
RN	RN5	---
R	R13	---
B	B1	---
C	C21	C4-9
Q	Q2	---
CR	CR1	---
Y	Y1	---

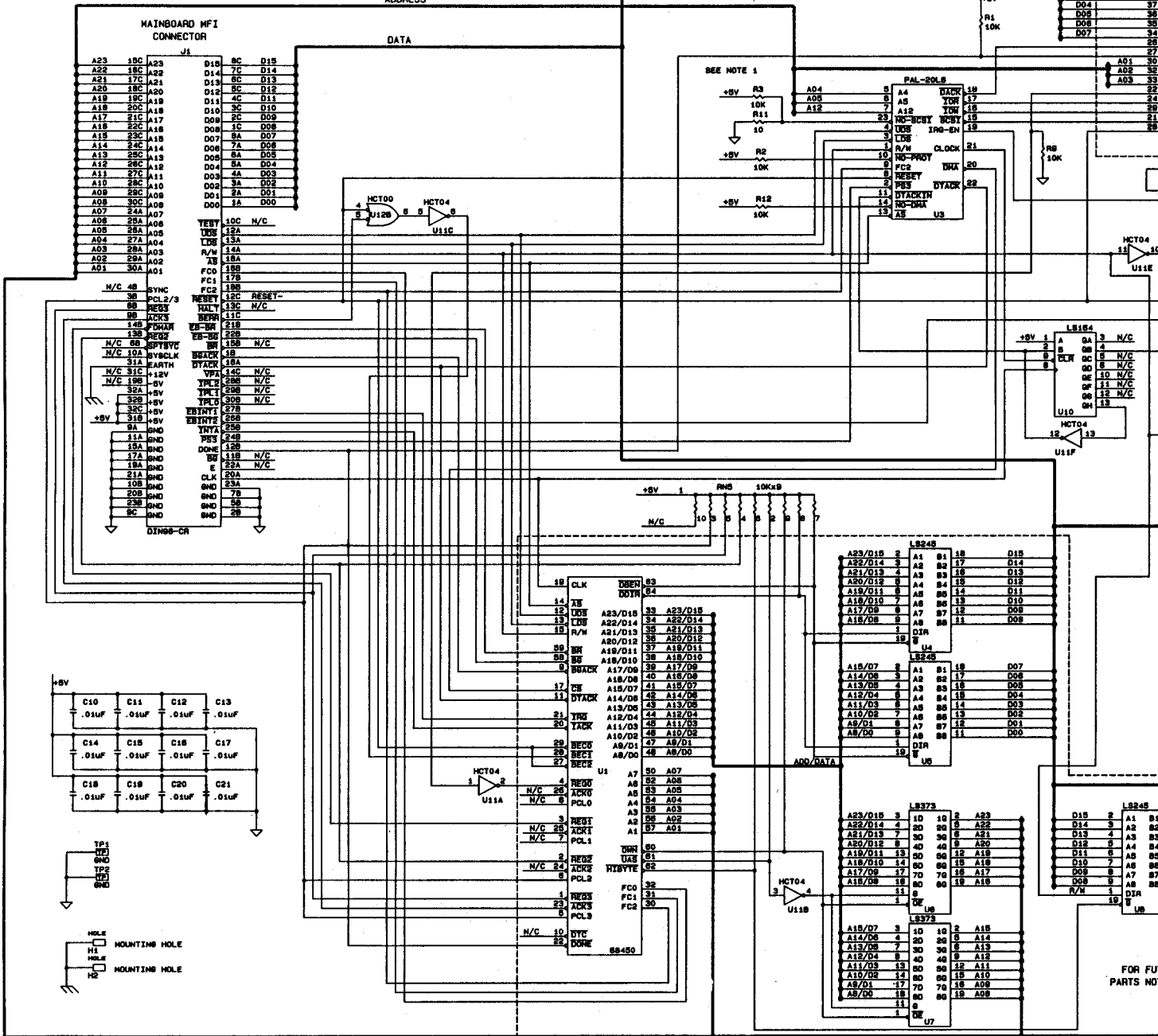

CAUTION
SUBJECT TO DAMAGE BY
STATIC ELECTRICITY

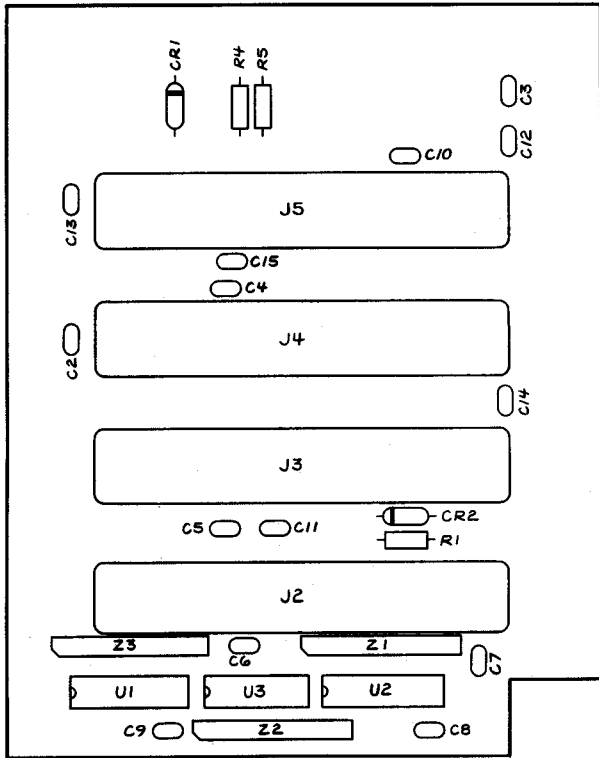

CKT 4 SIDE

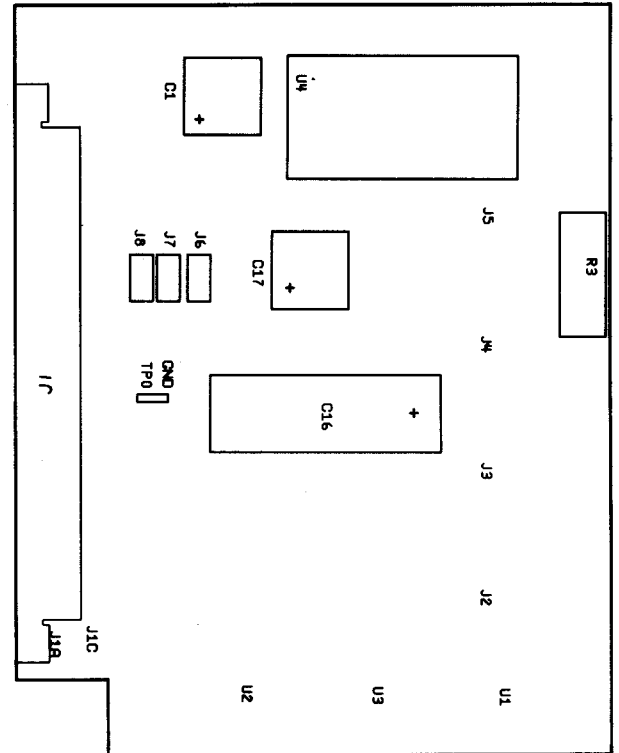

CKT 1 SIDE

9100A-1611

D

C

B

A

4 DB37 CONNECTORS TO THE I/O

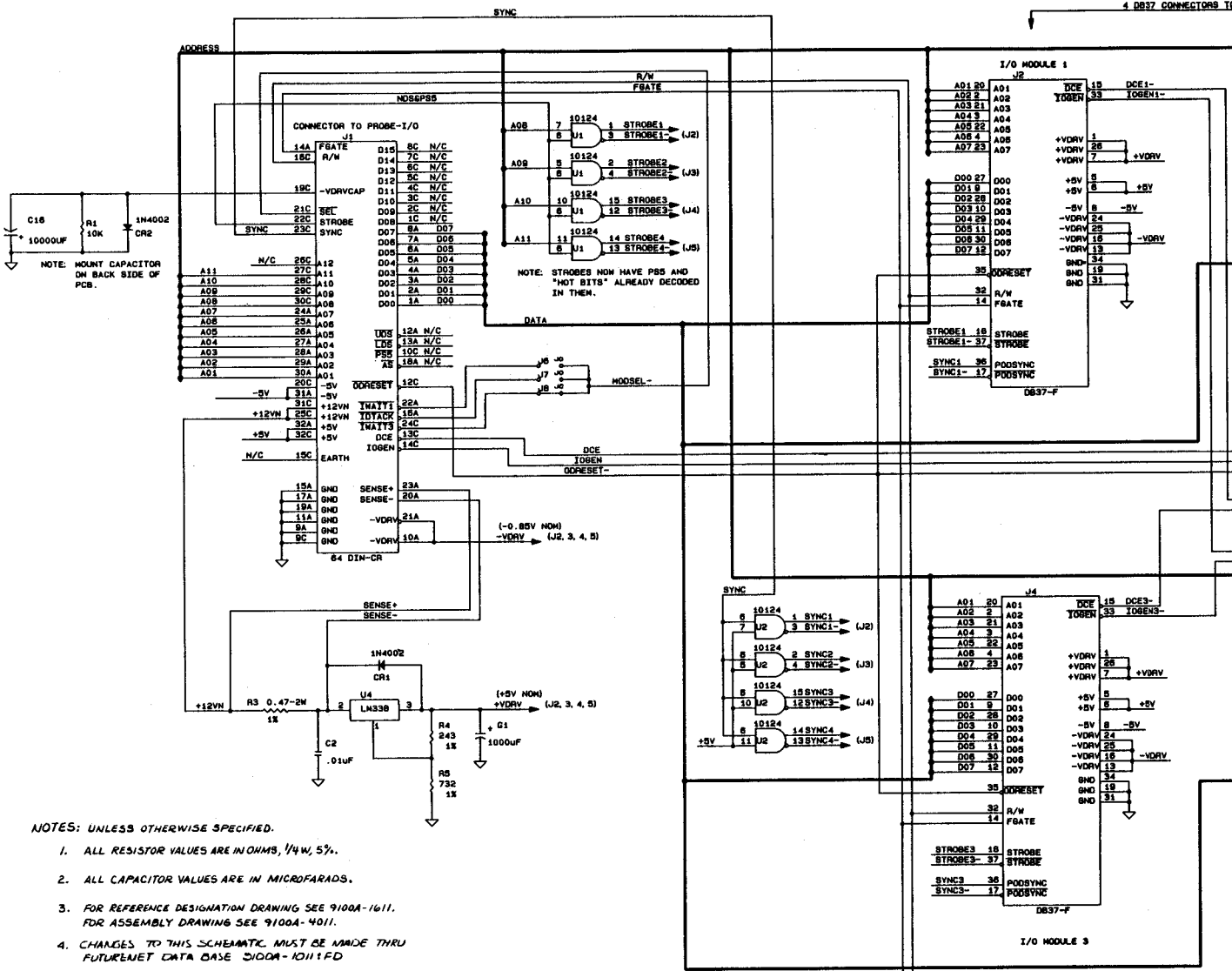

NOTES: UNLESS OTHERWISE SPECIFIED.

1. ALL RESISTOR VALUES ARE IN OHMS, 1/4W, 5%.
2. ALL CAPACITOR VALUES ARE IN MICROFARADS.
3. FOR REFERENCE DESIGNATION DRAWING SEE 9100A-1011. FOR ASSEMBLY DRAWING SEE 9100A-4011.
4. CHANGES TO THIS SCHEMATIC MUST BE MADE THRU FUTUREMET DATA BASE 9100A-1011.FD
5. ALL PARTS ARE LEADED ON THIS PCB
6. PCB IS TO BE 4 SIDED WITH POWER AND GROUND PLANES
7. U1 AND U2 SHOULD BE AS CLOSE AS POSSIBLE TO CONNECTORS J2, J3, J4, AND J5.

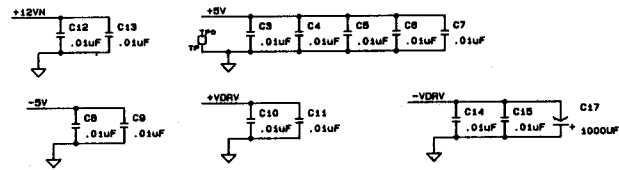
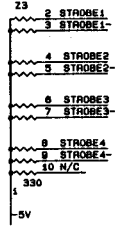
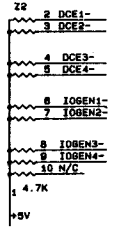
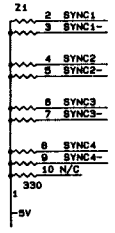

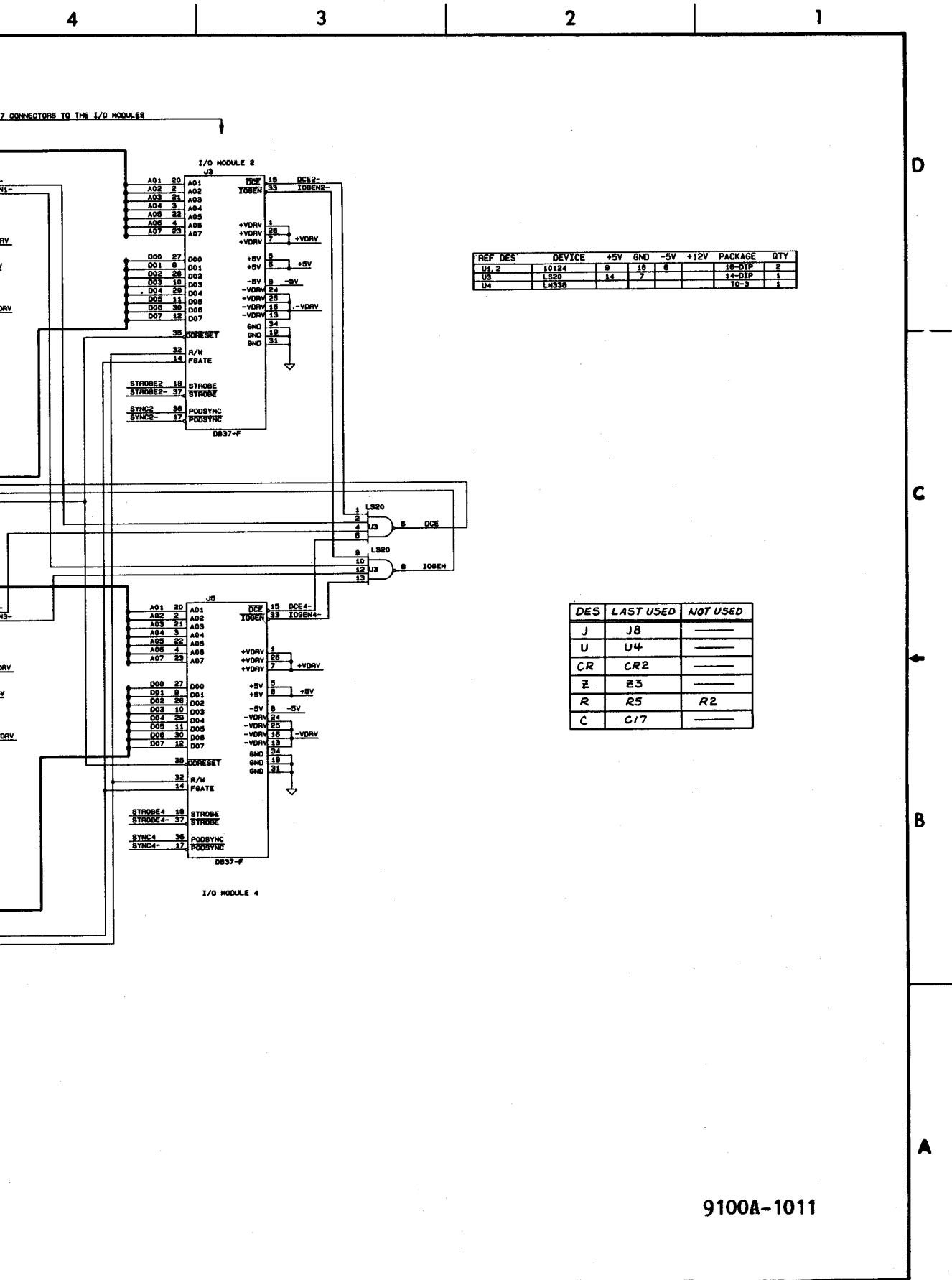

Figure 7-11. A11 I/O Connector PCA

D

C

B

A

CABLE AND CLIPS SHOWN FOR REFERENCE ONLY

24 PIN UUT CABLE SHOWN FOR REFERENCE ONLY

I/O MODULE CONNECTOR MODULE PCB (SMALL)

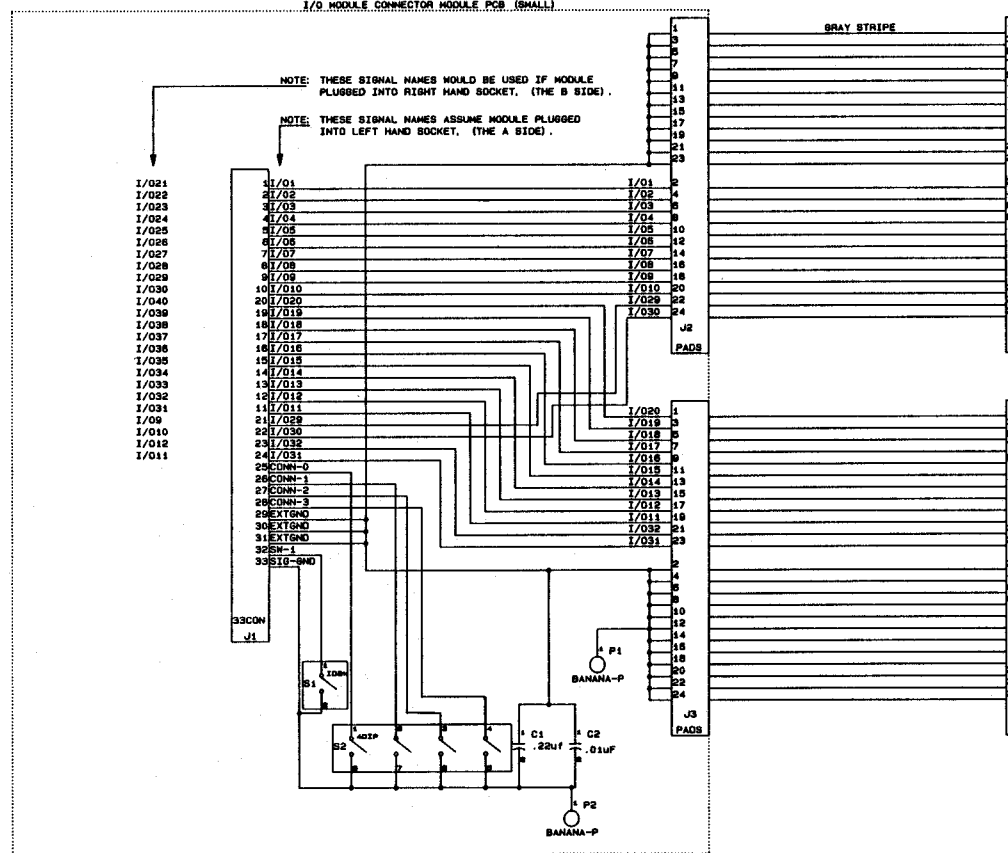

4 3 2 1

D
C
B
A

NOTES: UNLESS OTHERWISE SPECIFIED.

1. J2 AND J3 ARE REALLY ARRAYS OF SOLDER PADS WHERE THE CABLE ASSEMBLY WILL SOLDER IN.
2. SWITCH S1 IS THE "ID" SWITCH, ACCESSIBLE FROM THE OUTSIDE OF THE MODULE.
3. ALL RESISTOR VALUES ARE IN OHMS, 1/8W, 5%.
4. ALL CAPACITOR VALUES ARE IN MICROFARADS.

CABLE AND CLIPS SHOWN FOR REFERENCE ONLY

DIP CLIPS SHOWN FOR PIN NUMBER REF ONLY. 20 PIN FLYING LEAD ASSEMBLY SHOWN FOR COLOR REFERENCE ONLY.

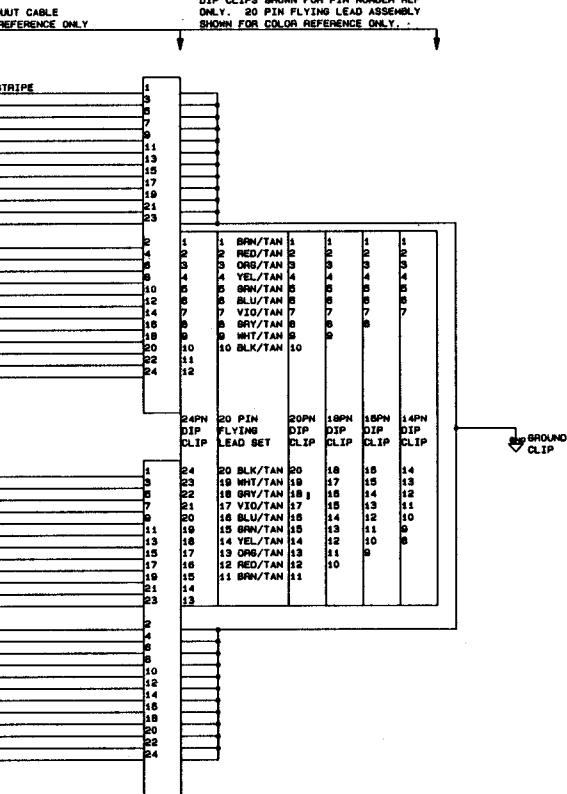

DES	LAST USED	NOT USED
J	J3	---
P	P2	---
S	S2	---
C	C2	---

9100A-1012

Figure 7-12. A12 DIP Clip Module (Half)

(CABLE AND CLIPS SHOWN FOR REFERENCE ONLY)

DIP CLIPS SHOWN FOR PIN NUMBER

I/O MODULE CONNECTOR MODULE PCB (FULL WIDTH)

40 PIN LATT CABLE SHOWN FOR REFERENCE

D

C

B

A

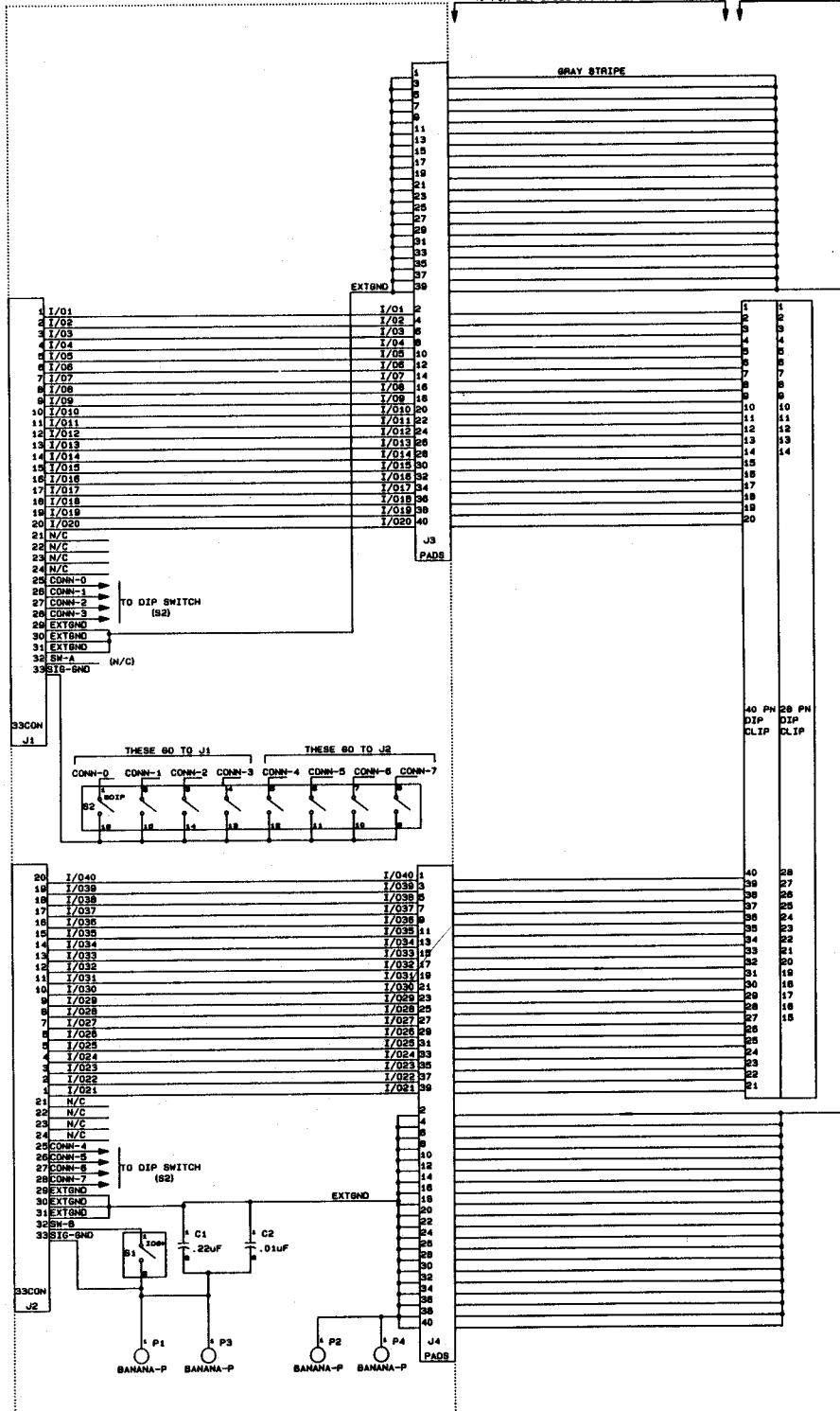

4

3

2

1

(FOR REFERENCE ONLY)
DIP CLIPS SHOWN FOR
FOR PIN NUMBER REF ONLY

- NOTES: UNLESS OTHERWISE SPECIFIED.
1. J3 AND J4 ARE REALLY ARRAYS OF SOLDER PADS WHERE THE CABLE ASSEMBLY WILL SOLDER IN.
 2. SWITCH S1 IS THE "ID" SWITCH, ACCESSIBLE FROM THE OUTSIDE OF THE MODULE.
 3. ALL RESISTOR VALUES ARE IN OHMS 1/8W, 5%.
 4. ALL CAPACITOR VALUES ARE IN MICROFARADS.

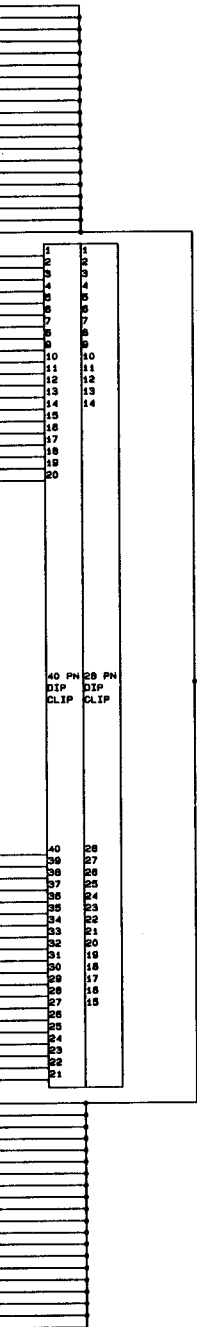

DES	LAST USED	NOT USED
J	J4	—
P	P4	—
S	S2	—
C	C2	—

D

C

B

A

9100A-1013

Figure 7-13. A13 DIP Clip Module (Full)

NOTES: UNLESS OTHERWISE SPECIFIED.

- 1. ALL RESISTOR VALUES ARE IN OHMS, 1/8W, 5%.
- 2. ALL CAPACITOR VALUES ARE IN MICROFARADS.
- 3. FOR ASSEMBLY DRAWING SEE 9100A-4014.
- 4. CHANGES TO THIS SCHEMATIC MUST BE MADE THRU FUTURENET, CAD DATA BASE NO. 9100-1014;FD.

DES	LAST USED	NOT USED
J	J2	
P	PH	
S	S1	
E	E1	

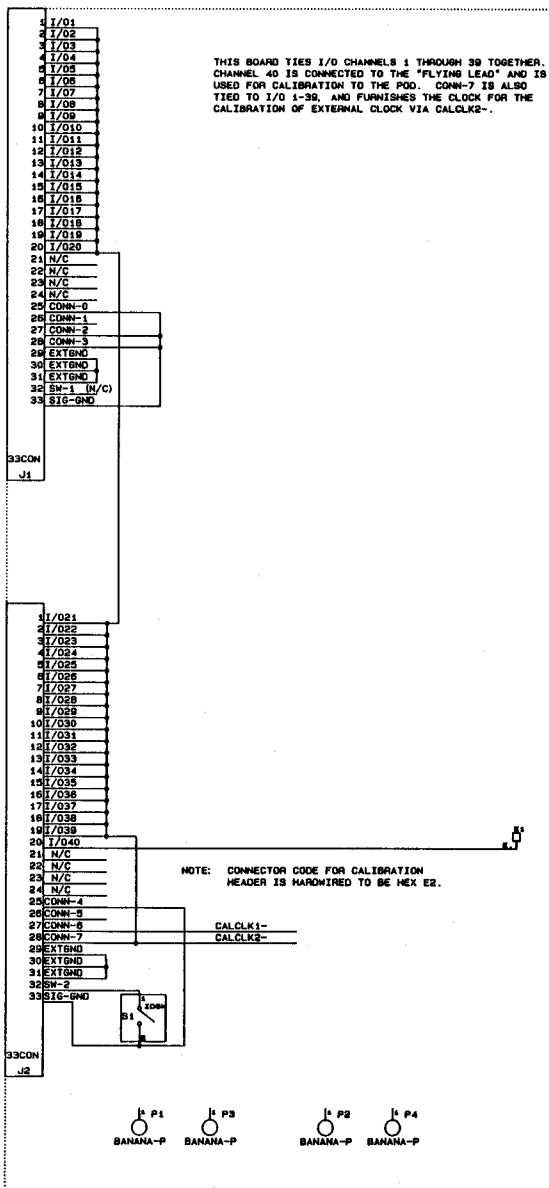

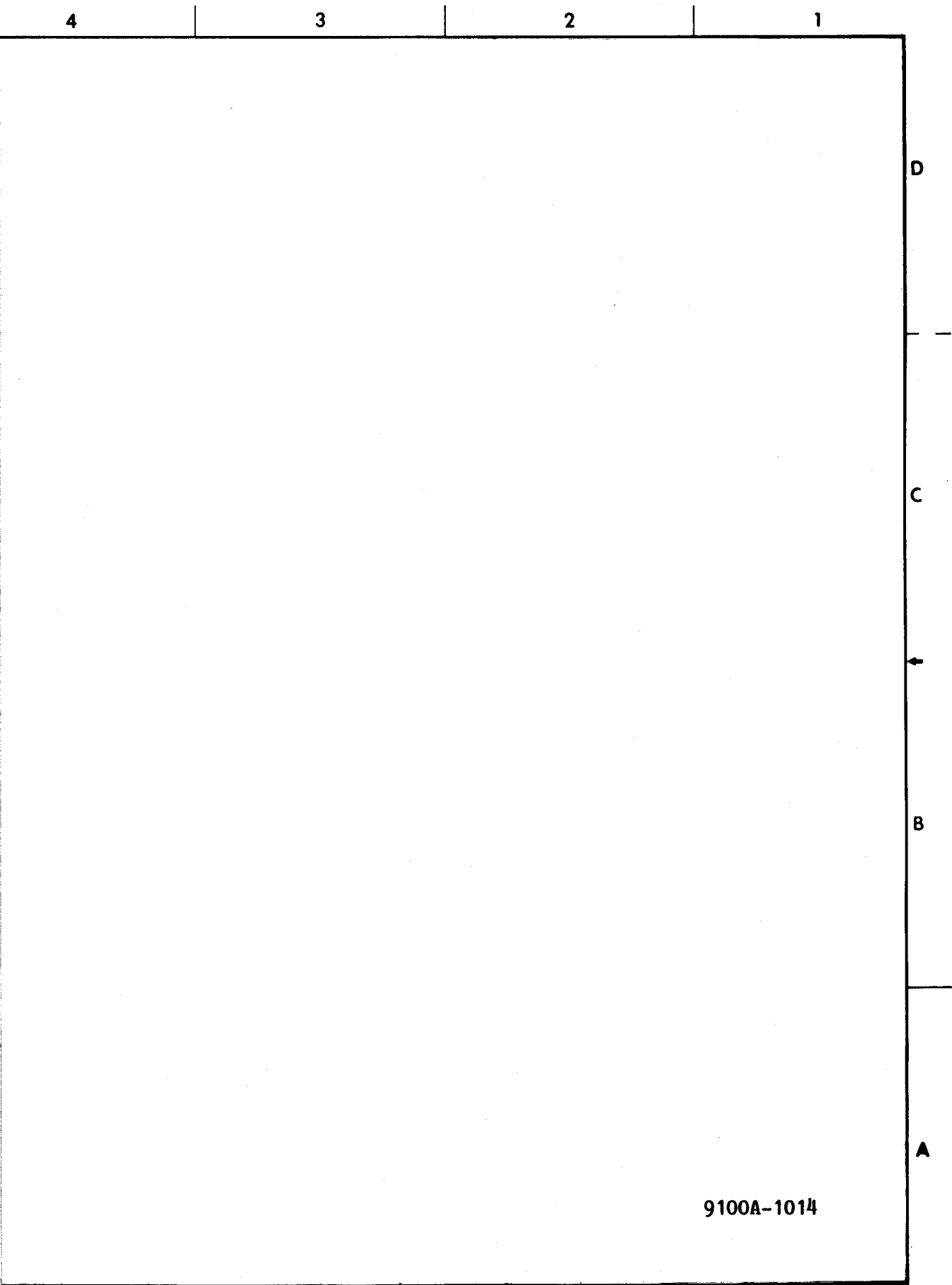
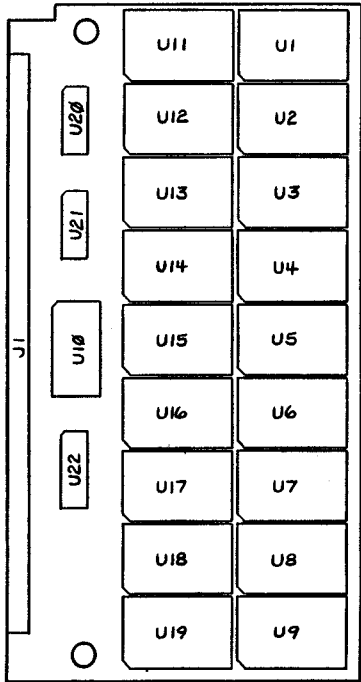
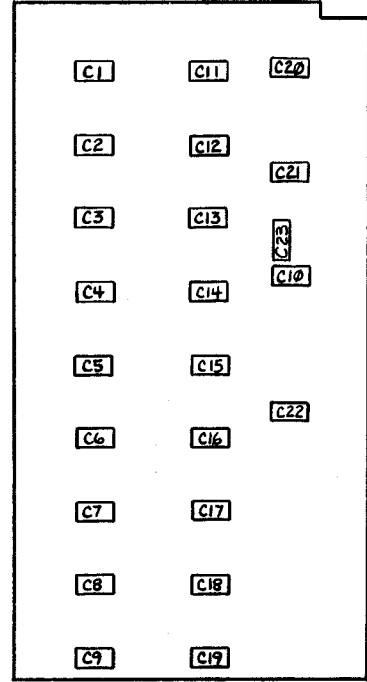

Figure 7-14. A14 Calibration Module PCA



CKT 4



CKT 1

9100A-1616

D
C
B
A

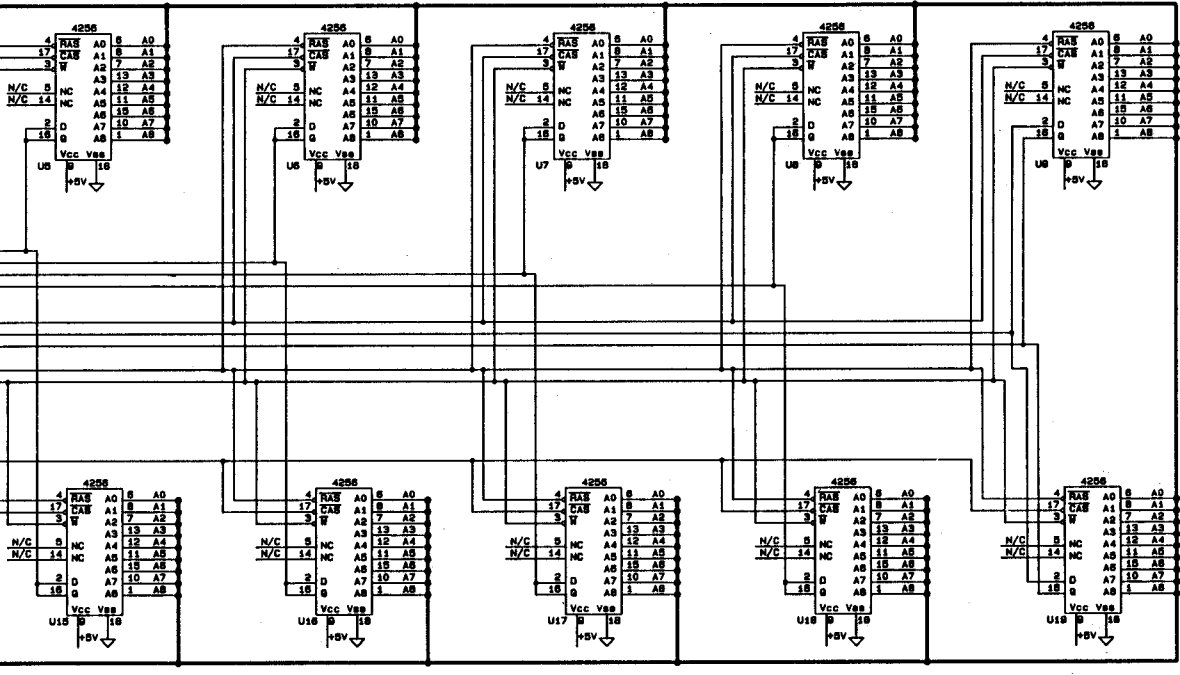

DES	LAST USED
J	J1
U	U22
C	C23

9100A-1016

Figure 7-15. A16 512K RAM Module

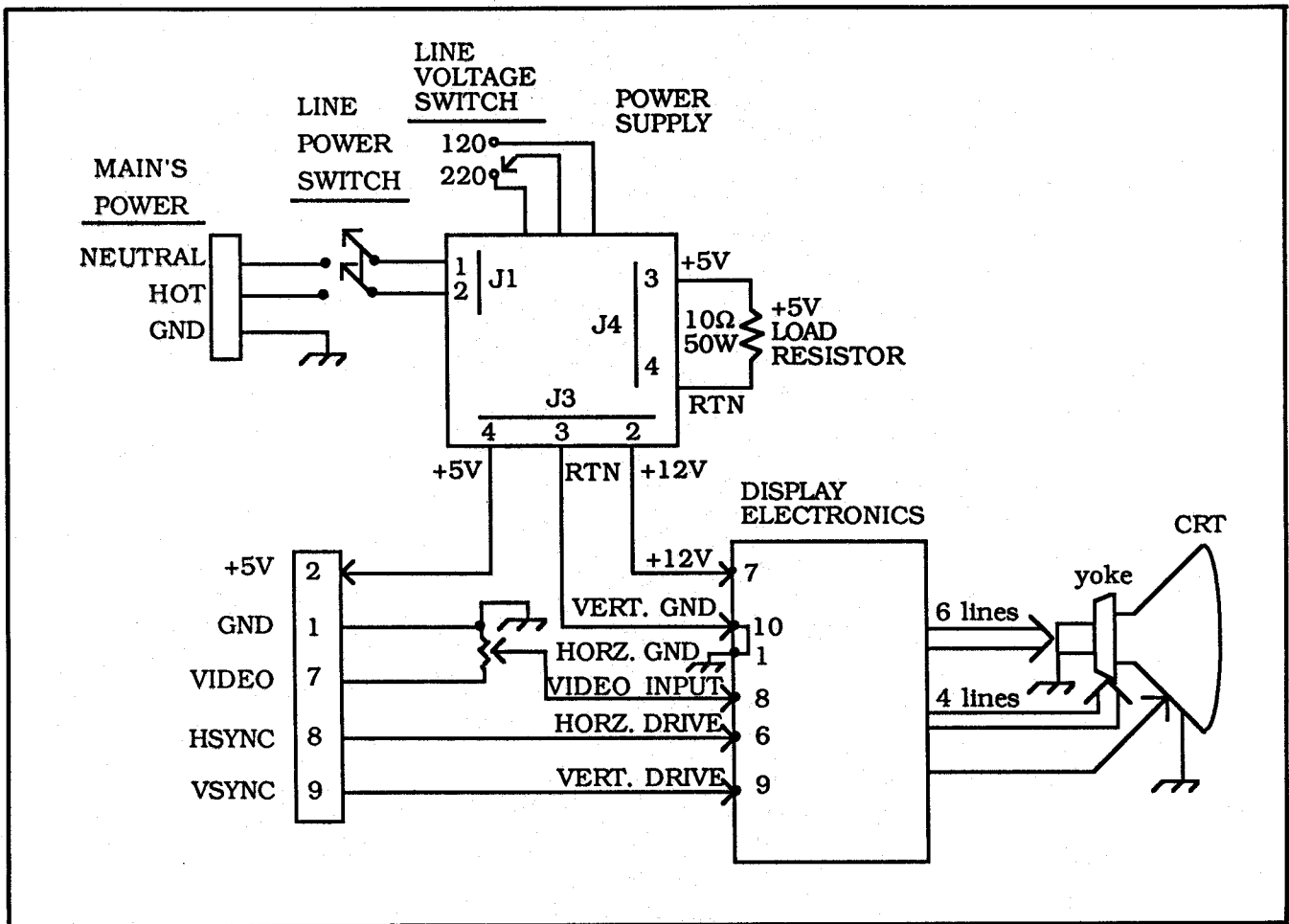

Figure 7-16. A19 Monochrome Monitor, Block Diagram

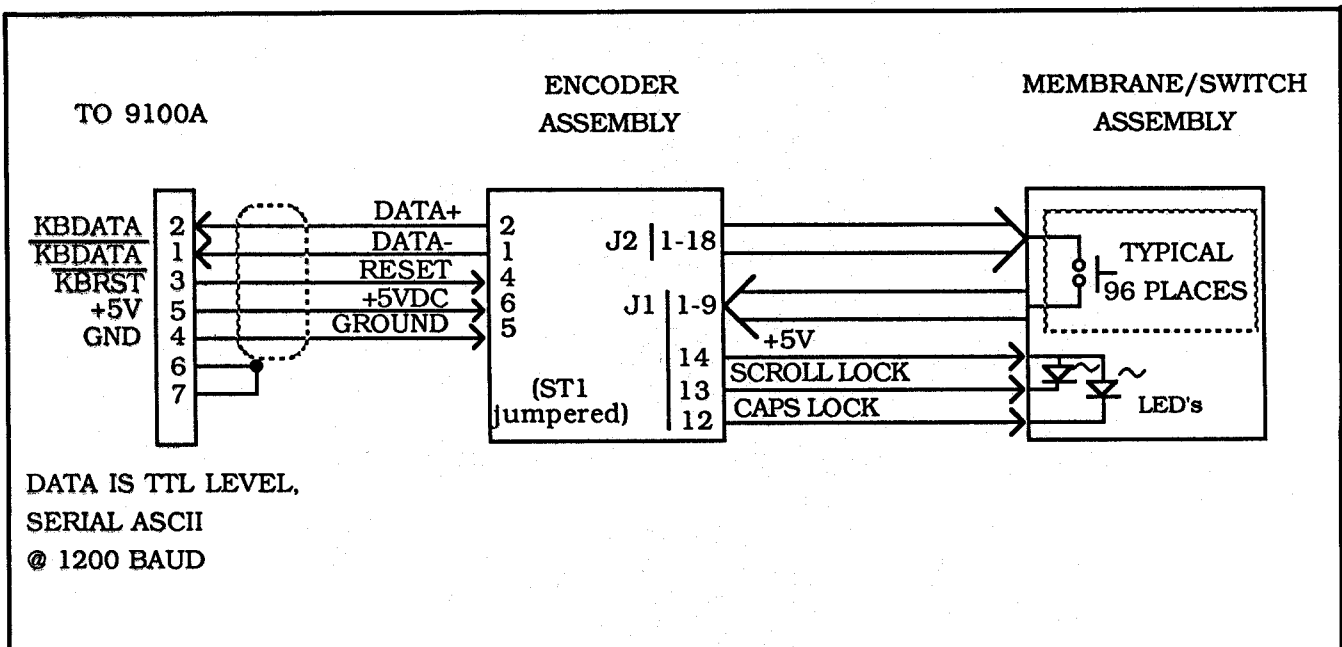
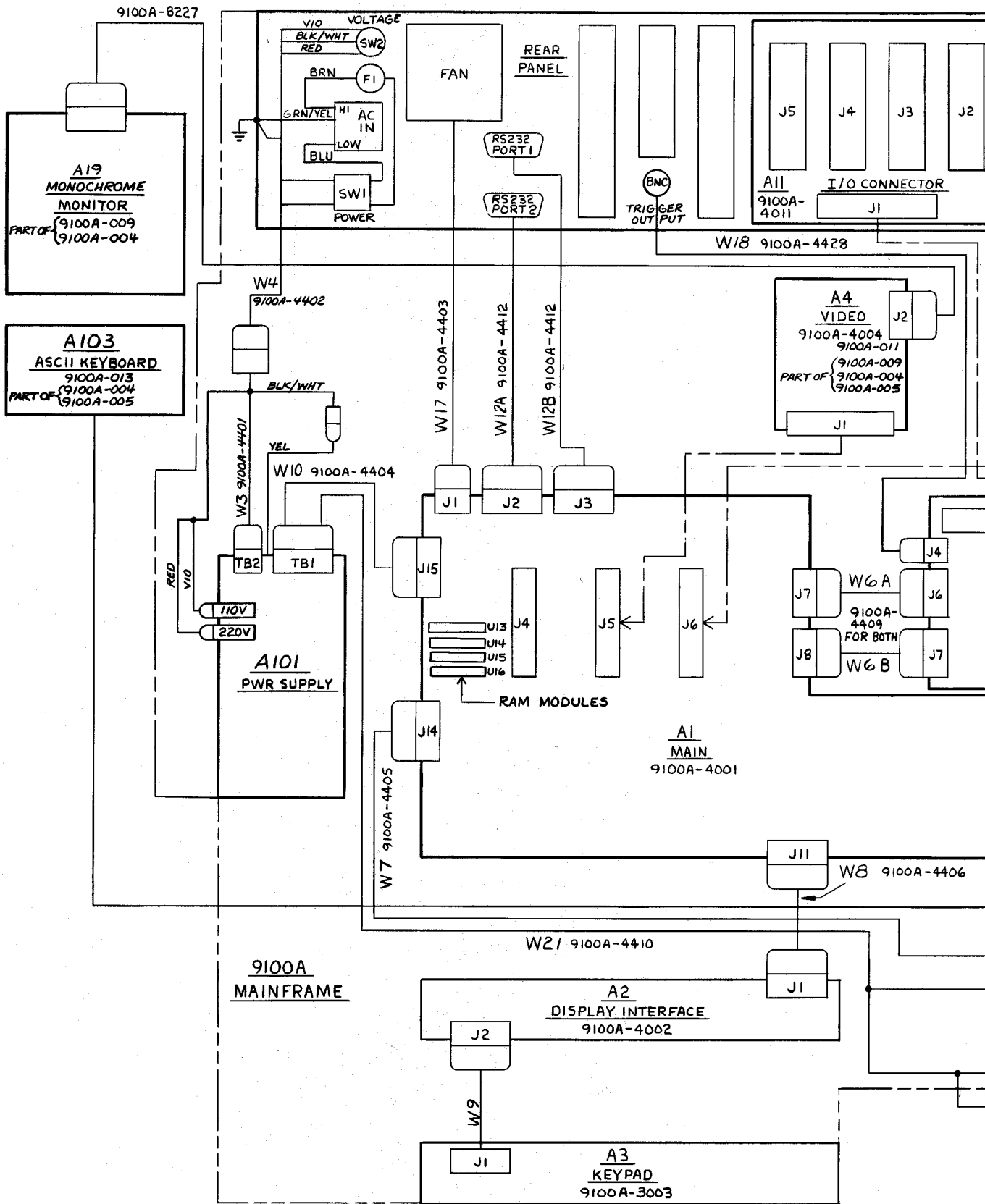
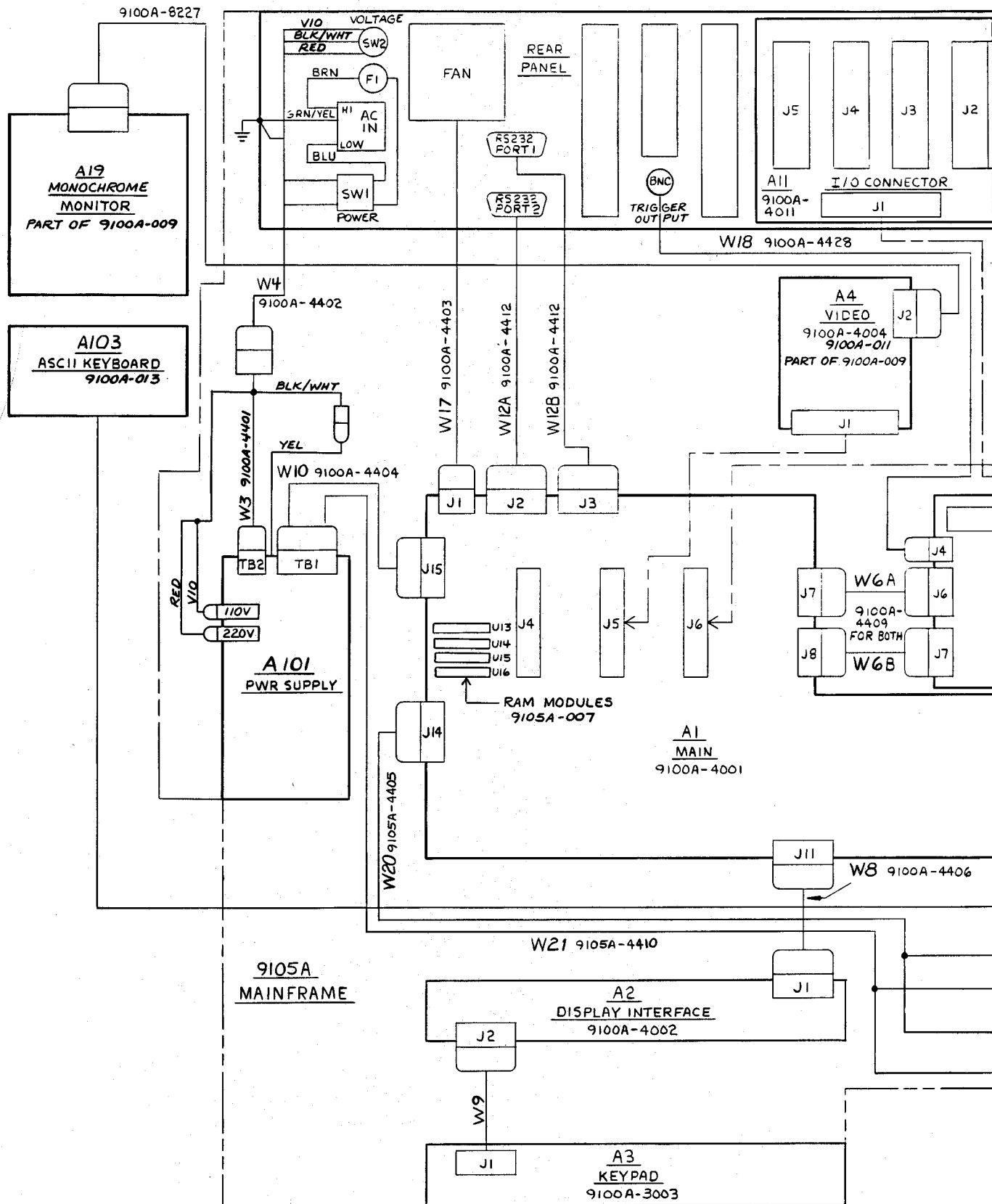

Figure 7-17. -013 Programmer's Keyboard, Block Diagram





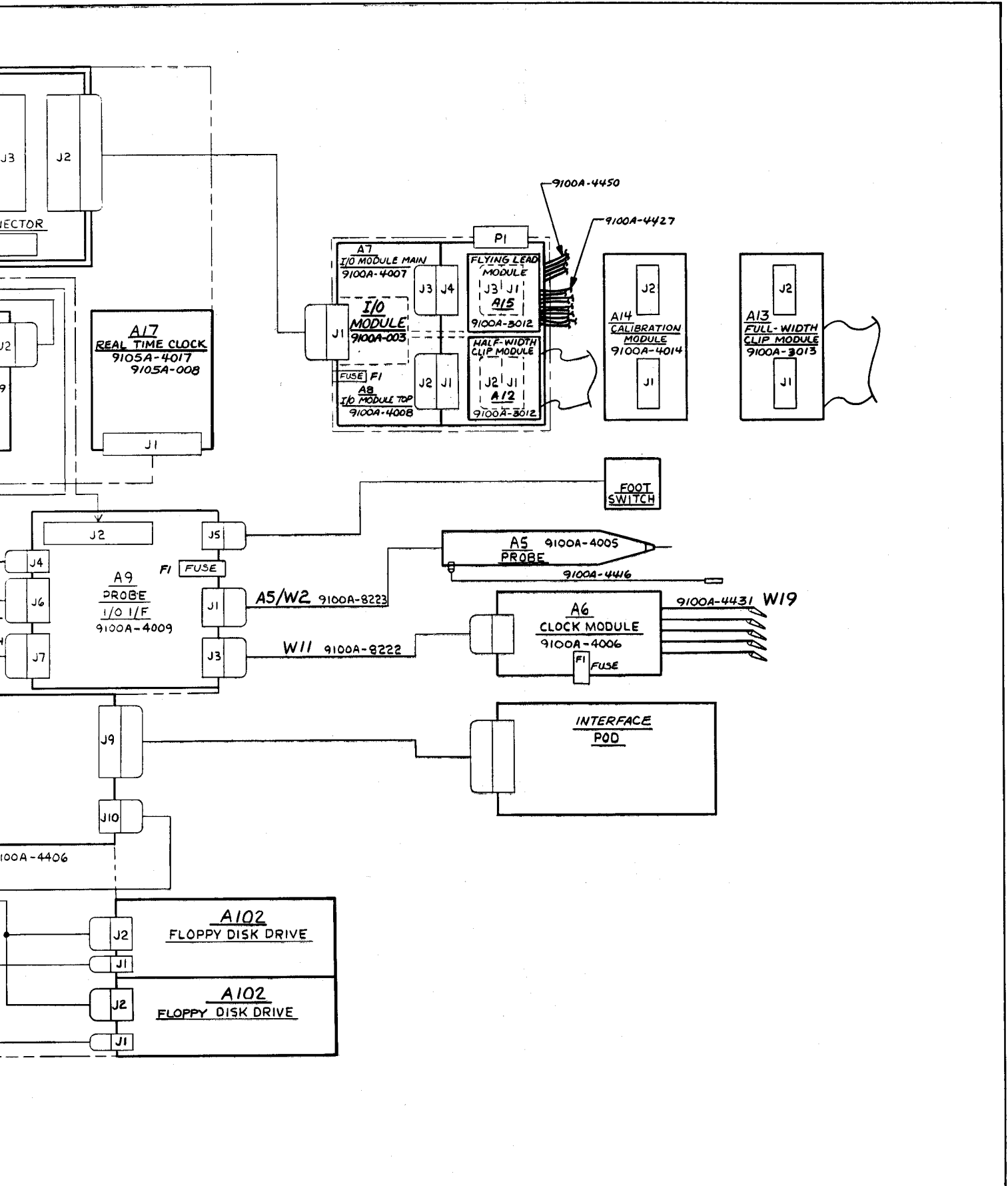

Figure 7-19. Interconnect Diagram, 9105A

INDEX

68000 Pin Assignments, 3-15
9100A Block Diagram, 3-6
9100A System, 4-10
9105A Block Diagram, 3-7
9105A System, 4-11

Access, Mainframe , 4-9
Access, Monitor, 4-19
Access, Operator Keypad/Display, 4-12
Accessories, 2-7
Address Bus, 3-13
Address Decoding Example, 3-72
Address Decoding, 3-24
Address Ranges, 3-14
Addresses, 3-64
Addressing, 3-70
Annunciators, 3-42
Asynchronous Execution, 3-23

Bus Arbitration, 3-16
Bus Error and Halt, 3-16
Bus Interface Timing Diagram, 3-74
Bus Interface, 3-70
Butt-Soldered DIP, 4-56

CRT and Yoke, Installation, 4-30
CRT and Yoke, Removal, 4-28
CRT, Replacement, 4-37
Calibration Data, Invalid , 4-52
Calibration Data, Restoring , 4-53
Calibration Data, Saving , 4-52
Calibration Data, Saving and Restoring , 4-51
Calibration Module Configuration Codes, 3-82
Calibration Module PCA, 7-23
Calibration Module, 3-85
Calibration, 4-45
Characters, Displayable , 3-38
Chip Channel Input, 3-84

Index

Chip Pattern Drive Output, 3-84
Chip Soldering, 4-63
Cleaning, 4-8
Cleaning, Fan Filter, 4-9
Cleaning, Floppy Disk Drive, 4-9
Clip Configuration Switch Settings, 4-72
Clock Module Interface, 3-50
Clock Module PCA, 7-13
Clock Module, 3-8, 3-63
Clock and Enable Mux, 3-75
Clock, 3-64
Connections, External , 2-3
Connector Codes, 3-83
Control Characters, 3-41
Control Register, 3-57, 3-77
Custom Chip Pin Description, 3-76
Custom Chip Selection, 3-73
Custom Chip Voltage Level Detection, 3-80
Custom Chip, 3-75
Custom Delay Chip, 3-50
Custom Logic Chip, 3-51

DIP Clip Module (Full), 7-22
DIP Clip Module (Half), 7-21
DIP Clip, 3-85
DTACK, 3-24
DTIO #1 (Channels A, B), 3-32
DTIO #2 (Channels C, D), 3-33
DTIO, 3-5, 3-30
Data Bus Buffers, 3-56
Data Bus, 3-13
Data Comparison Inputs, 3-78
Data Comparison and General Interrupts, 3-78
Data Strobe Control, 3-12
Dip-Clip Configuration Codes, 3-82
Disassembly, 4-15
Disassembly, Disk System, 4-14
Disk Drive Assemblies, Installation , 4-14
Disk Drive Assemblies, Removal, 4-14
Disk Drive, 3-33
Disk System, Disassembly, 4-14
Display Adjustment Locations, External, 4-35
Display Characters, 3-39
Display Interface PCA, 7-7
Display PCA, 4-27
Display Self Test, 4-43

Exception Processing, 3-17

FET Output, 3-83
Floppy Controller Addressing, 3-34
Floppy Disk Jumper Settings, 4-69
Floppy Drive Control Latch Outputs, 3-34
Floppy Drive Controller, 3-33
Flying Lead Module Configuration Switch Settings, 4-72
Footswitch Connector, 3-56
Full-Width Clip Module, 3-86
Fuse Changing, Clock Module, 4-7
Fuse Changing, I/O Module, 4-8
Fuse Changing, Mainframe, 4-7
Fuse Changing, Probe , 4-7
Fuse Detection, 3-78
Fuse Part Numbers, 4-8

General Control Latch, 3-77

Half Width Clip Module, 3-86
Hard Disk Controller, Removal , 4-14
Hard Disk System, 3-8, 3-35
Hot-Bit Decoding Examples, 3-73

I/O Connector Interface PCA, Removal, 4-16
I/O Connector Interface, 3-57
I/O Connector PCA, 7-20
I/O Module (Main) PCA, 7-14
I/O Module (Top) PCA, 3-85, 7-16
I/O Module -VDRV Voltage Regulator, 3-54
I/O Module Address Decoding, 3-71
I/O Module Command Register, 3-79
I/O Module Interface Connector, 3-53
I/O Module Overcurrent Detection, 3-55
I/O Module Self Test, 4-42
I/O Module, 3-69
I/O Module, 3-9, 3-68
Input Protection, 3-83
Installation, Disk Drive Assemblies, 4-14
Interconnect Diagram, 9100A, 7-25
Interconnect Diagram, 9105A, 7-26
Interface Pods, 2-7
Interrupt Vector Table, 3-19
Interrupts, 3-18

Key Values, 3-43
Keyboard, Programmer's, 3-67
Keypad PCA, 7-9
Keypad, Disassembly, 4-13

Level Indicator Operation, 3-62
Level Indicators, 3-62
Line Voltage, Mainframe , 4-3
Line Voltage, Monitor, 4-6
Logic Level Modes, 3-62
Logic Levels of NDRV and PDRV, 3-84

Index

MFI and Video Controller PCA Removal, 4-16
Main PCA (MC68000 Microprocessor), 3-9
Main PCA, 3-5, 7-3
Main PCA, Removal, 4-16
Main PCA, Signal and Pin Description, 3-9
Manual Set, 1-5
Metal Electrode Face (MELF), 4-56
Microfloppy Disk System, 3-5, 3-33
Microprocessor Status Latches, 3-20
Monitor Alignment Program, 4-33
Monitor Display PCA, 4-24
Monitor Display PCA, Installation, 4-26
Monitor Display PCA, Removal, 4-24
Monitor Rear Panel, 4-20
Monitor, 3-8, 3-67
Monitor, Access, 4-19
Monitor, Adjustment, 4-32
Monitor, Cover Removal, 4-19
Monitor, Front Bezel Removal, 4-19
Monitor, Power Supply Installation, 4-22
Monitor, Power Supply Removal, 4-21
Monitor, Power Supply, 4-21
Multi-Function Interface PCA, 7-19
Multi-Function Interface, 3-63

Notation Conventions, 1-6

Operator Keypad/Display, Removal, 4-12
Operator Keypad/Display, Separation, 4-12
Operator's Display, 3-8, 3-35
Operator's Keypad, 3-8, 3-42
Options, 2-6
Oscilloscope Use in Probe Compensation, 4-47

PLCC Lead Index, 4-59
PLCC Soldering, 4-63
Parts, Replaceable, 5-1
Plastic Leaded Chip Carrier (PLCC), 4-55
Pod Control Port Bit Assignment, 3-27
Pod Interface Pinout, 3-29
Pod Interface, 3-27
Pod Self Test, 4-41
Power Requirements, 2-3
Power Supply Lead Connections, 4-23
Power Supply Pinout, 3-35
Power Supply Removal, 4-14
Power Supply, 3-8, 3-35
Power-Up Self Test Responses, 4-39
Power-Up Self Test, 4-38
Privilege Modes, 3-17
Probe Common Ground Clip, 3-61
Probe Compensation Square Wave, 4-48
Probe Compensation, 4-46

Probe Data Input, 3-47
Probe External 16-bit Counter, 3-49
Probe Fuse Blown Detection, 3-49
Probe I/O Interface, 3-44
Probe I/O Module Interface Addressing, 3-46
Probe I/O Module Interface PCA, Removal, 4-16
Probe I/O Module Interface, 3-42
Probe I/O PCA, 7-17
Probe Interface, 3-46
Probe Light Drive and Control, 3-49
Probe Offset Correction, 4-46
Probe Operation Voltages, 3-49
Probe Response Timing, 3-61
Probe Self Test, 4-38
Probe Speed Specifications, 3-60
Probe Threshold Voltage Calculation, 3-47
Probe Tip Input, 3-59
Probe, 3-59, 7-12
Probe/Pulser, 3-8, 3-59
Programmer Keyboard, Access, 4-17
Programmer's Keyboard, 3-9, 3-67
Pulser Pulse Width, 3-62
Pulser, 3-61
Push Button Switch, 3-62

RAM Configuration (U83), 3-25, 4-68
RAM Configuration, 3-24
RAM Parity, 3-26
RAM Refresh, 3-25
RAM Timing, 3-25
ROM Select Logic, 3-26
ROM, 3-26
Read Cycle, 3-14
Read-Modify-Write Cycle, 3-14
Rear Panel Features, 2-5
Removal, Disk Drive Assemblies, 4-14
Removal, Hard Disk Controller, 4-14
Removal, I/O Connector Interface PCA, 4-16
Removal, MFI and Video Controller PCA, 4-16
Removal, Main PCA, 4-16
Removal, Power Supply, 4-14
Removal, Probe I/O Module Interface PCA, 4-16
Repair Techniques, 4-60
Repair, Clip and Flying Lead Modules, 4-71
Repair, Clock Module, 4-67
Repair, Components, 4-54
Repair, Display and Keypad, 4-66
Repair, Floppy Disk Drive, 4-69
Repair, General, 4-54, 4-66
Repair, Hard Disk and Controller, 4-69
Repair, I/O Connector, 4-67
Repair, I/O Module, 4-71
Repair, Main PCA, 4-66

Index

Repair, Monochrome Monitor, 4-71
Repair, Multi-Function Interface, 4-70
Repair, Power Supply, 4-68
Repair, Probe I/O, 4-67
Repair, RAM Modules, 4-68
Repair, Single-Point Probe, 4-67
Repair, Video Controller, 4-70
Required Tools and Test Equipment, 2-8, 4-4
Reset Signal Description and Generation, 3-23
Ribbon Cable Connections, 3-43

SCSI, 3-64
SMT Rework Tools and Supplies, 4-65
SOIC Lead Index, 4-59
SOIC Soldering, 4-64
Screen Overlay, 4-18
Screen Overlay, Installation, 4-18
Screen Overlay, Recommended Use, 4-18
Screen Overlay, Removal, 4-18
Self Test Routines, 4-38
Self Test, Display, 4-42
Self Test, I/O Module, 4-42
Self Test, Pod, 4-41
Self Test, Power-Up, 4-38
Self Test, Probe, 4-38
Service Information, 2-7
Shipping Information, 2-7
Side Features, 2-4
Signal Descriptions, 3-10
Small Outline Integrated Circuit (SOIC), 4-55
Small Outline Transistor (SOT), 4-56
Software Calibration, 4-48
Software Calibration, I/O Module to External, 4-50
Software Calibration, I/O Module to Pod, 4-50
Software Calibration, Probe to External (Clock Module), 4-48
Software Calibration, Probe to Pod, 4-49
Specifications, 2-10
Static Awareness, 4-54
Status Register, 3-56
Stop Counter, 3-53
Surface Mount Footprint, 4-57
Surface Mount Repair, 4-54
Surface Mount Technology, 4-54
Switch Settings, Clip Configuration 4-72
Switch Settings, Flying Lead Module Configuration 4-72
Sync Pulse Isolation, 3-55
System Components, 9100A, 2-6
System Components, 9105A, 2-6
System Connections, 4-9

Test Equipment, 2-7
Theory of Operation, 3-5
Tools and Supplies, 4-64
Troubleshooting, 4-54
Typical Probe Pulser Amplitude, 3-61

U18 Truth Table, 3-77

VDRV Voltage Regulator Simplified Schematic, 3-54

VHI and VLO for TTL and CMOS Logic Levels, 3-80

Vacuum Fluorescent Display, 3-35, 3-37

Video Character Data Format, 3-66

Video Controller PCA, 7-10

Video Controller, 3-65

Video Display Address Mapping, 3-65

Video Output, 3-67

Video RAM, 3-65

Video, 3-64

Voltage Threshold Levels, 3-48

Write Cycle, 3-14