

VARKON

VARKON INSTRUCTION BOOKLET

This booklet provides game operation, bookkeeping, game adjustment, diagnostic, and self-test procedures for VARKON. For installation and special maintenance information refer to the blue-covered game manual.

SPECIAL CONSIDERATIONS WHEN REPLACING CIRCUIT BOARDS

CPU Board

1. Revision level 7 CPU Boards (batteries located on lower left corner at board) of later boards must be used.
2. Must be equipped with blue-labeled Flipper ROMs and blue-labeled Game ROMs.
3. Jumpers W3, W10, W11, W14, W17, W19, W20, and W22 must be connected. Jumpers W4, W9, W12, W15, W16, W18, W21, and W23 must be removed. With the exception of W25, (Factory Setting Jumper) all other jumpers are not changed.

Driver Board

Must be equipped with zero-ohm resistors or wire jumpers (W9-W16) in place of switch matrix drive series resistors R204-R211.

Sound Board

Must be jumpered for ROM operation and be equipped with Sound ROM 10. (Jumpers W2, W5, W7, W9, W10, W12, and W15 connected; W3, W4, W6, W8, W11, and W13 removed).

Power Supply Board

1. Model D 8345 board required (equipped with relay).
2. Fuse F4 (10A SB) for flipper solenoids must be installed.

Display Boards

Model C 8363 Master Display and 7-digit Slave Displays required.

Game Operation

GAME OVER MODE

Turn game ON, player 1 display shows High Score to Date and Game Over lights come on. The High Score to Date alternates between player 1 and player 2 displays, and all playfield lamps on both Lower Level Playfield (LLP) and Upper Level Playfield (ULP) cycle in Attract mode.

CREDIT POSTING

Insert coins; sound produced, number of credits displayed. If maximum credits* level is exceeded by coin or High Score to Date, credits are posted correctly and coin lockout de-energizes until remaining credits are below maximum. No credits may be won, and coins are rejected while coin lockout is de-energized. With 1 credit posted single player play is possible. With 2 or more credits posted, two player play is possible, or a single player can play more than one game.

Lane Change is a trademark of Williams Electronics, Inc.

GAME START

A ball should be on both the ULP and LLP. With credits posted press 1- or 2-Player Start. The number of credits displayed is reduced appropriately, player 1 display flashes, player 2 display counts down from "50" and a ball is served into play on the ULP. This ball should be caught with a flipper and sent into play. The game program can be set to serve a no-score ball a specific number of times. If, after this number of serves, player has not yet scored points, the ball in play is considered "drained". With only one player, the player 2 score display counts down from "30" in between subsequent balls. When two play, the other player score display counts down from "50" between turns.

Completing targets 1-2-3-4-5 lights the spinner ramp chamber. Making the chamber when lit for 5,000 or more holds the ULP ball in the chamber and the other ball is ejected onto the LLP. When the LLP ball drains, the ULP ball is kicked onto the ULP to continue play.

UPPER LEVEL PLAYFIELD

Bonus Advance

Targets 1-2-3-4-5 and V-A-R advances the bonus. Completing K-O-N advances the bonus multiplier 2X-3X-5X-10X.

Targets 1-2-3-4-5

Completing targets lights points for 1,000, Bull's-Eye for 25,000, and advances lighting of ramp chamber value from 5,000 to 50,000.

V-A-R Rollovers

Completing V-A-R advances jet bumper value 30-300-3,000.

***Lane Change*™ Feature**

The V-A-R and K-O-N lamps can be rotated by pushing the *Lane Change* button on the control panel.

Extra Ball

Lighting the ramp chamber for 20,000* or more and then making the chamber lights the Bull's-Eye target for a possible Extra Ball. Extra Balls, up to 4* at one time, are also earned by exceeding adjustable score levels.

LOWER LEVEL PLAYFIELD

Bonus Advance

Completing targets 6-7-8-9-10 collects and advances the bonus (20-40-60-80 thousand). Making A and B targets advance the bonus multiplier (2X-3X-4X-5X).

Special

Topping out the bonus at 80,000 and the multiplier at 5X scores a special 50,000 points.*

TILT

Ball in play is tilted on third* closure of Plumb Bob and playfield tilts. A single slam tilt returns game to Game Over mode.

MATCH

Match digits appear* in Ball-in-Play display and Game Over lamps go off: game then enters attract mode.

*Indicates game program adjustable features.

BOOKKEEPING AND GAME EVALUATION

(Functions 01-17)

1. Set AUTO-UP/MANUAL-DOWN switch to AUTO-UP and depress ADVANCE pushbutton. Test 04 is indicated in the credits display, Function 00 in Match display, and Game Identification in Player 1 display.
2. Operate the ADVANCE pushbutton to display Functions 01 thru 04 on the Match display (See Table 1) and record the corresponding totals (number of coins and total paid credits) from the Player 1 display. (To review a total that has been advanced past, set switch to MANUAL-DOWN and operate the ADVANCE pushbutton).
3. Operate the ADVANCE pushbutton to display Functions 05, 06, and 07 in the Match display and record the corresponding free credit totals from the Player 1 display.
4. Operate the ADVANCE pushbutton to display Function 08 in the Match display. Total credits is indicated in the Player 1 display and total free credits in the Player 2 display.
5. Operate the ADVANCE pushbutton to display Function 09 thru 12 in the Match display and record the corresponding totals from the Player 1 display.
6. Operate the ADVANCE pushbutton to display Functions 13 thru 17 in the Match display and record the corresponding totals from the Player 2 display.
7. With switch set to MANUAL-DOWN operate ADVANCE to display Function 50 in the Match Display. From Function 50 you can return to game over or zero audit totals and return to game over. Perform step 8. a. or 8. b. as desired.
8.
 - a. To return to game over, set the switch to AUTO-UP and depress ADVANCE.
 - b. **To zero audit totals** and return to game over set switch to AUTO-UP, operate the credit button to display 35 in the Player 1 display, and depress ADVANCE.

Table 1. Audit Totals

| FUNCTION | DESCRIPTION | |
|----------|---|--------------------|
| | PLAYER 1 | PLAYER 2 |
| 00 | Game Identification (2502 1) | — |
| 01 | Coins, Left chute (closest to coin door hinge) | — |
| 02 | Coin, center chute | — |
| 03 | Coin, right chute | — |
| 04 | Total Paid Credits | — |
| 05 | Special Credits | — |
| 06 | Replay Score Credits | — |
| 07 | Match Credits | — |
| 08 | Total Credits | Free Credits |
| 09 | Total Extra Balls | — |
| 10 | Ball Time in Minutes | — |
| 11 | Total Balls Played | — |
| 12 | Current High Score to Date | — |
| 13 | Backup High Score to Date | High Score to Date |
| 14 | Extra Ball 1 Score | Credits Awarded |
| 15 | Extra Ball 2 Score | Times exceeded |
| 16 | Extra Ball 3 Score | Times exceeded |
| 17 | Extra Ball 4 Score | Times exceeded |

GAME ADJUSTMENT PROCEDURE

(Functions 13-41)

Coin door must be open to change settings.

1. Set AUTO-UP/MANUAL-DOWN switch to AUTO-UP and depress the ADVANCE pushbutton. Test 04 is indicated in the Credits display, Function 00 in Match display, and game identification in Player 1 display.
2. **To raise** Function number in Match display, operate ADVANCE pushbutton with switch set to AUTO-UP. **To lower** Function number, operate ADVANCE with switch set to MANUAL-DOWN.
3. With desired Function indicated in Match display, **raise** value in player 1 display by operating credit button with switch set to AUTO-UP; **lower** value by operating credit button with switch set to MANUAL-DOWN. Value left in Player 1 display is the new setting. For values see Table 2, and for pricing Table 3.
4. Repeat steps 2 and 3 until all required adjustments have been made.
5. Operate ADVANCE until Function 50 is indicated in Match display. From Function 50 you can return to game over or **restore factory settings**. Perform step 6 or 7 as desired.
6. To return to game over, depress ADVANCE with switch set to AUTO-UP.
7. To restore factory settings **and** zero audit totals:
 - a. Operate Credit button with switch set to AUTO-UP until 45 is indicated in Player 1 Display.
 - b. Depress ADVANCE. The game returns to Test 04, Function 00.
 - c. Set switch to MANUAL-DOWN and depress ADVANCE to indicate Function 50.
 - d. Set switch to AUTO-UP and depress ADVANCE.

RESETTING HIGH SCORE TO DATE

1. Using game adjustment procedure, set Function 13 to the desired reset value.
2. Depress HIGH SCORE RESET pushbutton.

FACTORY AUDIT TOTALS

(Functions 42-49)

The factory audit functions are not assigned.

Table 2. Game Adjustments

| FUNCTION | DESCRIPTION | NOTES | *FACTORY SETTING |
|----------|---|-------|------------------|
| 13 | Back Up High Score to Date | 1 | 1,000,000 |
| 14 | Replay 1 Score [Times exceeded] | 2 | 500,000 |
| 15 | Replay 2 Score [Times exceeded] | 2 | 1,000,000 |
| 16 | Replay 3 Score [Times exceeded] | 2 | 1,500,000 |
| 17 | Replay 4 Score [Times exceeded] | 2 | 0 |
| 18 | Maximum Credits | 3 | 30 |
| 19 | Standard and Custom Pricing Control: (00-08) | 4 | 01/02 |
| 20 | Left Coin Slot Multiplier | 4 | 01/09 |
| 21 | Center Coin Slot Multiplier | 4 | 04/45 |
| 22 | Right Coin Slot Multiplier | 4 | 01/18 |
| 23 | Coin Units Required for Credit | 4 | 01/05 |
| 24 | Coin Units Bonus Point | 4 | 00/45 |
| 25 | Minimum Coin Units | 4 | 00 |
| 26 | Match: 00 = Match ON; 01 = Match OFF | 2 | 01 |
| 27 | Special: 00 = Awards Credit; 01 = Awards Extra Ball; 02 = Awards Points | - | 02 |
| 28 | Replay Scores: 00 = Awards Credit, 01 = Awards Extra Ball | - | 01 |
| 29 | Maximum Plumb Bob Tilts | - | 03 |
| 30 | Number of Balls (03 or 05) | - | 05 |
| 31 | Number of No Score flipper serves before end of ball: Tens digit = ULP, Units digit = LLP | 5 | 33 |
| 32 | Bonus Multiplier Memory 00 = Memory for both LLP and ULP 01 = LLP Memory only 02 = ULP Memory only 03 = No Memory 04 = LLP Memory during same ball and ULP Memory 05 = LLP Memory during same ball only 06 = ULP Memory only 07 = No Memory | - | 00 |
| 33 | Ramp Chamber Lamp Control 00 = Memory, not reset when collected 01 = No Memory, not reset when collected 02 or 03 = Value reduced by 5K for next ball, not reset when collected 04 = Memory, reset upon collection 05 = No Memory, reset upon collection 06 or 07 = Value reduced by 5K for next ball, reset when collected | - | 04 |
| 34 | Jet Bumper and Spinner Memory 00 = Memory for both 01 = Spinner Memory only 02 = Jet Bumper Memory only 03 = No Memory | - | 03 |
| 35 | ULP Targets 1-5 and Bull's-Eye Extra Ball Lamp Memory 00 = Memory for both 01 = Extra Ball Lamp Memory only 02 = Targets 1-5 Memory only 03 = No memory | - | 02 |
| 36 | Extra Ball Difficulty Control 00(Liberal)-09(Conservative) | 6 | 03 |
| 37 | LLP BONUS: 00 = No Memory 01 = Memory | 7 | 00 |
| 38 | Not Used | - | 00 |
| 39 | Background and Attract Mode Sound Control 00 = Background & Attract Mode 01 = Attract Mode Only 02 = Background Only 03 = No sound | - | 00 |
| 40 | High Score Credits | 1,2 | 03 |
| 41 | Maximum Extra Balls at one time (00 = No extra balls) | - | 04 |

NOTES:

* Second Factory Setting value is with jumper W25 on CPU Board connected.

[] Description in brackets shown in Player 2 Display.

- Function 13 may be set to any multiple of 100,000 points. With Function 40 set to zero and Function 13 set to any score but zero, the High Score to Date feature operates but no credits are awarded.
- Although credits may be awarded for Replay scores (Functions 14-17) **it is not recommended**. Three credits are awarded for High Score to Date (Function 40). Change Function 26 to 00 to award Match credits.
- Setting Maximum Credits (Function 18) to zero places the game in a free play mode.
- With Function 19 set to 00, Functions 20-25 must be set manually. Refer to Table 3 for 8 standard pricing schemes (selected by values of 01-08 for Function 19) and custom pricing values.
- A "NO SCORE FLIPPER SERVE" is when a ball is ejected into play and no points are scored before the ball returns to the outhole.
- Spinner ramp shot to Ramp Chamber lights Bull's-Eye target for Extra Ball with Ramp Chamber values needed shown below:
00=5K (1 completion of targets 1-5), 01=10K, 02=15K, 03=20K, 04=25K, 05=30K, 06=35K, 07=40K, 08=45K, and 09=50K (10 completions of targets 1-5).
- LLP Bonus always reset when collected for 80,000.

LLP=Lower Level Playfield ULP = Upper Level Playfield

DIAGNOSTIC PROCEDURES

Display Digits Test

1. Set AUTO-UP/MANUAL-DOWN switch to MANUAL-DOWN and depress ADVANCE. Displays should indicate all 0's.
2. Set the switch to AUTO-UP. Displays should sequence from all 0's thru all 9's. Comma segments should come on when odd digits are displayed.
3. To stop cycling, set switch to MANUAL-DOWN. Operate ADVANCE pushbutton to step through the tests one number at a time. Set switch to AUTO-UP to resume cycling.

Sound Test

1. From Display Digits Test depress ADVANCE with the switch set to AUTO-UP. Test 00 should be indicated in the Credits display and the Match display should sequence from 00 thru 06. Different sounds should be produced for 00, 01, 02, 03, and 04.
2. To continuously pulse a single sound, set the toggle switch to MANUAL-DOWN. Operate ADVANCE pushbutton to sequence through sounds one at a time. Set toggle switch to AUTO-UP to resume sequencing.

Table 3. Standard and Custom Price Settings

| COIN DOOR MECHANISM | CREDITS | FUNCTION | | | | | | | |
|--|-------------------------------|----------|----|----|----|----|----|----|--|
| | | 19 | 20 | 21 | 22 | 23 | 24 | 25 | |
| Twin-Quarter Quarter, Dollar, Quarter | 1/25¢, 3/50¢, 7/\$1 | 00 | 03 | 12 | 03 | 02 | 12 | 00 | |
| | 1/25¢, 3/50¢, 7/\$1 coin only | 00 | 03 | 14 | 03 | 02 | 00 | 00 | |
| | 1/25¢, 7/\$1 coin only | 00 | 01 | 07 | 01 | 01 | 00 | 00 | |
| | 1/25¢, 3/50¢, 6/\$1 | 00 | 01 | 04 | 01 | 01 | 02 | 00 | |
| | 1/25¢, 6/\$1 coin only | 00 | 01 | 06 | 01 | 01 | 00 | 00 | |
| | 1/25¢, 5/\$1 | 00 | 01 | 04 | 01 | 01 | 04 | 00 | |
| | 2/50¢, 5/\$1 | 00 | 01 | 04 | 01 | 01 | 04 | 02 | |
| | 1/25¢, 5/\$1 coin only | 00 | 01 | 05 | 01 | 01 | 00 | 00 | |
| | •1/25¢, 4/\$1 | 01 | 01 | 04 | 01 | 01 | 00 | 00 | |
| | 2/50¢, 4/\$1 | 00 | 01 | 04 | 01 | 01 | 00 | 02 | |
| | •1/50¢, 2/75¢, 3/4 x 25¢ | 05 | 03 | 15 | 03 | 04 | 15 | 00 | |
| | 4/\$1 or 5 x 25¢ | | | | | | | | |
| | 1/50¢, 3/\$1, 4/\$1.25 | 00 | 03 | 12 | 03 | 04 | 15 | 00 | |
| | 1/50¢, 3/\$1, 7/\$2 | 00 | 12 | 48 | 12 | 14 | 96 | 18 | |
| | •1/50¢, 3/\$1, 6/\$2 | 03 | 01 | 04 | 01 | 02 | 04 | 00 | |
| 1/50¢ | 00 | 01 | 04 | 01 | 02 | 00 | 00 | | |
| IDM, 5DM, 2DM | •1/IDM, 3/2DM, 10/5DM | 02 | 09 | 45 | 18 | 05 | 45 | 00 | |
| | 2/1DM, 5/2DM, 14/5DM | 00 | 13 | 65 | 26 | 05 | 65 | 00 | |
| 20-Cent, 50-Cent | 1/20¢, 3/50¢ | 00 | 06 | 00 | 15 | 05 | 00 | 00 | |
| 1 Franc, 10 Franc, 5 Franc | •1/2F, 3/5F only, 8/10F only | 04 | 01 | 16 | 06 | 02 | 00 | 00 | |
| 25 Cent, | •1/25¢, 4/1G | 06 | 01 | 00 | 04 | 01 | 00 | 00 | |
| 1 Guilder, | 1/25¢, 5/1G | 00 | 01 | 00 | 04 | 01 | 04 | 00 | |
| Twin 100 Yen | 2/100Y | 00 | 02 | 00 | 02 | 01 | 00 | 00 | |
| 1 Franc or | 1/1F, 3/2F | 00 | 01 | 01 | 01 | 01 | 02 | 00 | |
| Twin-1 Franc | 1/1F | 00 | 01 | 01 | 01 | 01 | 00 | 00 | |
| 5 Franc, | •1/5F, 2/10F | 07 | 01 | 00 | 02 | 01 | 00 | 00 | |
| 10 Franc | •1/10F | 08 | 01 | 00 | 02 | 02 | 00 | 00 | |
| Twin-2 Franc | •1/2F | 03 | 01 | 04 | 01 | 01 | 00 | 00 | |
| 10, 20 Franc | •1/10F, 2/20F | 07 | 01 | 00 | 02 | 01 | 00 | 00 | |
| Twin-1 Sucre | 1/3S, 2/5S | 00 | 02 | 00 | 02 | 05 | 00 | 00 | |

•Indicates standard price settings by adjusting only Function 19. For other price settings, set Function 19 to 00 and set Functions 20 through 25 to the values indicated in the chart.

Lamp Test

From Sound Test depress ADVANCE with the switch set to AUTO-UP. Test 01 should be indicated in the Credits display and all multiplexed lamps should flash.

Lamp

No. Function

- 01 Same Player Shoots Again
- 02 Ball in Play
- 03 Tilt
- 04 Game Over
- 05 Match
- 06 Not Used
- 07 B Arrow, LLP
- 08 A Arrow, LLP
- 09 2X Bonus Multiplier, LLP
- 10 3X Bonus Multiplier, LLP
- 11 4X Bonus Multiplier, LLP
- 12 5X Bonus Multiplier, LLP
- 13 20 Bonus, LLP, (20,000)
- 14 40 Bonus, LLP, (40,000)
- 15 60 Bonus, LLP, (60,000)
- 16 80 Bonus, LLP, (80,000)

- 17 6 Target LLP
- 18 7 Target LLP
- 19 8 Target LLP
- 20 9 Target LLP
- 21 10 Target LLP
- 22 5 Target ULP
- 23 4 Target ULP
- 24 3 Target ULP
- 25 2 Target ULP
- 26 1 Target ULP
- 27 Extra Ball, ULP
- 28 1K Bonus, ULP
- 29 2K Bonus, ULP
- 30 4K Bonus, ULP
- 31 8K Bonus, ULP
- 32 16K Bonus, ULP
- 33 2X Bonus Multiplier, ULP
- 34 3X Bonus Multiplier, ULP
- 35 5X Bonus Multiplier, ULP
- 36 10X Bonus Multiplier, ULP
- 37 Jet Bumper 30, ULP
- 38 Jet Bumper 300, ULP
- 39 Jet Bumper 3000, ULP
- 40 1-Player Start Button (Front Panel)
- 41 Lane A, ULP
- 42 Lane V, ULP
- 43 Flipper Return Lane R, ULP
- 44 K, ULP
- 45 O, ULP
- 46 N, ULP
- 47 Spinner 1000, ULP
- 48 2-Player Start Button (Front Panel)
- 49 Ramp Chamber Lane 5,000, ULP
- 50 Ramp Chamber Lane 10,000, ULP 51 Ramp Chamber Lane 15,000, ULP

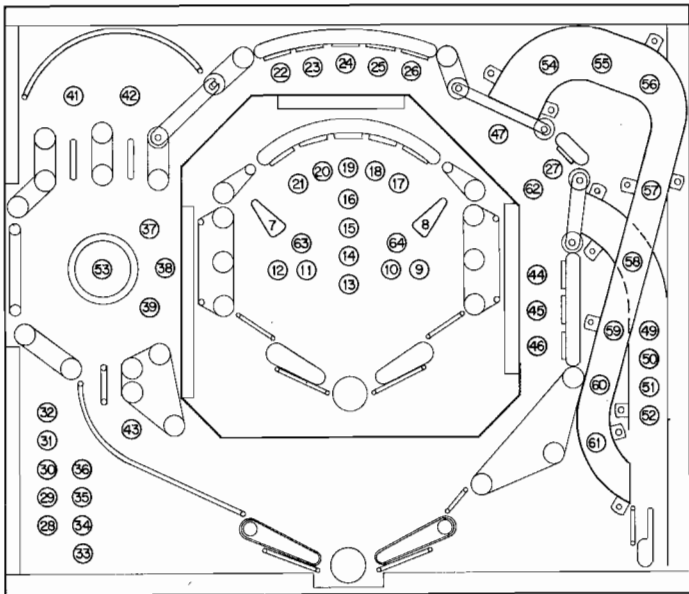

- 52 Ramp Chamber Lane 20,000, ULP
- 53 Jet Bumper, ULP
- 54 Spinner Ramp, ULP (Nearest Spinner)
- 55 Spinner Ramp, ULP
- 56 Spinner Ramp, ULP
- 57 Spinner Ramp, ULP
- 58 Ramp Chamber Lane, ULP
- 59 Spinner Ramp, ULP
- 60 Spinner Ramp, ULP
- 61 Spinner Ramp, ULP (Nearest Ramp Chamber)
- 62 Extra Ball 25,000, ULP
- *63 Left EYE Special, LLP
- *64 Right EYE Special, LLP

NOTE:

LLP = Lower Level Playfield
 ULP = Upper Level Playfield

*Left and right determinations are made with Playfield removed from game (PLAY SIDE UP) and flippers closest to observer.

Figure 1. Playfield Lamp Locations

| COLUMN ROW | 1 YEL-BRN 2J5-8 | 2 YEL-RED 2J5-9 | 3 YEL-ORN 2J5-6 | 4 YEL-BLK 2J5-7 | 5 YEL-GRN 2J5-3 | 6 YEL-BLU 2J5-5 | 7 YEL-VIO 2J5-1 | 8 YEL-GRY 2J5-2 |
|---------------------------|----------------------------------|--------------------------------------|------------------------|--------------------------|---|---|---|--|
| 1 RED- BRN 2J7-1 | Same Player Shoots Again 1 | 2X Bonus Multiplier, LLP 9 | 6 Target LLP 17 | 2 Target ULP 25 | 2X Bonus Multiplier, ULP 33 | Lane A, ULP 41 | Ramp Chamber Lane 5,000, ULP 49 | Spinner Ramp, ULP 57 |
| 2 RED- BLK 2J7-2 | Ball in Play 2 | 3X Bonus Multiplier, LLP 10 | 7 Target LLP 18 | 1 Target ULP 26 | 3X Bonus Multiplier, ULP 34 | Lane V, ULP 42 | Ramp Chamber Lane 10,000, ULP 50 | Ramp Chamber Lane, ULP 58 |
| 3 RED- ORN 2J7-3 | Tilt 3 | 4X Bonus Multiplier, LLP 11 | 8 Target LLP 19 | Extra Ball, ULP 27 | 5X Bonus Multiplier, ULP 35 | Flipper Return Lane R, ULP 43 | Ramp Chamber Lane 15,000, ULP 51 | Spinner Ramp, ULP 59 |
| 4 RED- YEL 2J7-4 | Game Over 4 | 5X Bonus Multiplier, LLP 12 | 9 Target LLP 20 | 1K Bonus, ULP 28 | 10X Bonus Multiplier, ULP 36 | K, ULP 44 | Ramp Chamber Lane 20,000, ULP 52 | Spinner Ramp, ULP 60 |
| 5 RED- GRN 2J7-5 | Match 5 | 20 Bonus, LLP (20,000) 13 | 10 Target LLP 21 | 2K Bonus, ULP 29 | Jet Bumper 30, ULP 37 | O, ULP 45 | Jet Bumper, ULP 53 | Spinner Ramp, ULP (Nearest Ramp Chamber) 61 |
| 6 RED- BLU 2J7-6 | Not Used 6 | 40 Bonus, LLP (40,000) 14 | 5 Target ULP 22 | 4K Bonus, ULP 30 | Jet Bumper 300, ULP 38 | N, ULP 46 | Spinner Ramp, ULP (Nearest Spinner) 54 | Extra Ball 25,000, ULP 62 |
| 7 RED- VIO 2J7-9 | B Arrow, LLP 7 | 60 Bonus, LLP (60,000) 15 | 4 Target ULP 23 | 8K Bonus, ULP 31 | Jet Bumper 3000, ULP 39 | Spinner 1000, ULP 47 | Spinner Ramp, ULP 55 | Left EYE Special, LLP 63 |
| 8 RED- GRY 2J7-8 | A Arrow, LLP 8 | 80 Bonus, LLP (80,000) 16 | 3 Target ULP 24 | 16K Bonus, ULP 32 | 1-Player Start Button (Front Panel) 40 | 2-Player Start Button (Front Panel) 48 | Spinner Ramp, ULP 56 | Right EYE Special, LLP 64 |

Figure 2. Lamp Matrix

Solenoid Test

1. From Lamp Test depress ADVANCE with the switch set to AUTO-UP. Test 02 should be indicated in the Credits display. The Match display sequences from 01 thru 25. Corresponding solenoids 01 thru 24 are pulsed. Flipper relay is de-energized with subtest 25.
2. To continuously pulse a single solenoid set switch to MANUAL-DOWN. Operate ADVANCE pushbutton sequence through the solenoids one at a time. Set switch to AUTO-UP to resume sequencing.

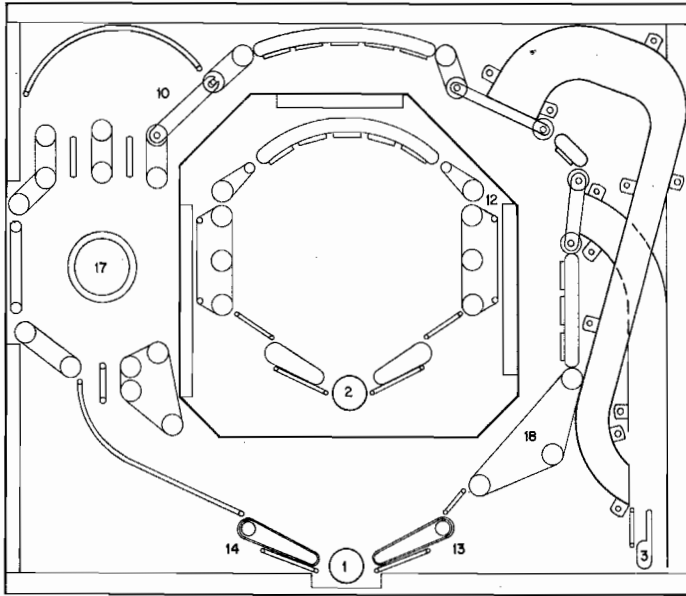

| Sol. No. | Function | |
|-----------------|------------------------------------|-----------------------------|
| 01 | ULP Outhole Eject | 12 LLP General Illumination |
| 02 | LLP Outhole Eject | 13 ULP/LLP Flipper Select |
| 03 | ULP Ramp Chamber | 14 ULP/LLP Flipper Select |
| 04 | Rear Panel Lightning Bolt (Top) | 15 Not Used |
| 05 | Rear Panel Lightning Bolt (Middle) | 16 Coin Lockout |
| 06 | Rear Panel Lightning Bolt (Bottom) | 17 ULP Jet Bumper |
| 07 | Not Used | 18 ULP Right Side Kicker |
| 08 | Not Used | 19 Not Used |
| 09 | Not Used | thru |
| 10 | ULP General Illumination | 22 |
| 11 | Cabinet General Illumination | |

NOTE:
 LLP = Lower Level Playfield
 ULP = Upper Level Playfield

Figure 3. Playfield Solenoid Locations and Solenoid Chart

Table 4. Solenoid Connections

| SOL. NO. | FUNCTION | WIRE COLOR | CONNECTIONS | DRIVER TRANS. | SOLENOID PART NO. |
|----------|------------------------------------|------------|------------------------|---------------|---------------------------|
| 01 | ULP Outhole Eject | GRY-BRN | 2P11-4, 8P2-29 | Q15 | SG1-23-850DC |
| 02 | LLP Outhole Eject | GRY-RED | 2P11-5, 8P2-30, 8P5-16 | Q17 | SG1-23-850DC |
| 03 | ULP Ramp Chamber | GRY-ORN | 2P11-7, 8P2-31 | Q19 | SG1-23-850DC |
| 04 | Rear Panel Lightning Bolt (Top) | GRY-YEL | 2P11-8, 9P1-10 | Q21 | |
| 05 | Rear Panel Lightning Bolt (Middle) | GRY-GRN | 2P11-9, 9P1-11 | Q23 | |
| 06 | Rear Panel Lightning Bolt (Bottom) | GRY-BLU | 2P11-3, 9P1-12 | Q25 | |
| 07 | Not Used | | | Q27 | |
| 08 | Not Used | | | Q29 | |
| 09 | Not Used | | | Q31 | |
| 10 | ULP General Illumination | BRN-RED | 2P9-7, 8P2-32 | Q33 | 5580-09613-00 |
| 11 | Cabinet General Illumination | BRN-ORN | 2P9-1 | Q35 | 5580-09613-00 |
| 12 | LLP General Illumination | BRN-YEL | 2P9-2, 8P2-33, 8P5-15 | Q37 | 5580-09613-00 |
| 13 | ULP/LLP Flipper Select | BRN-GRN | 2P9-3, 8P2-34 | Q39 | 5580-09613-00 |
| 14 | ULP/LLP Flipper Select | BRN-BLU | 2P9-4, 8P2-35 | Q41 | 5580-09613-00 |
| 15 | Not Used | | | Q43 | |
| 16 | Coin Lockout | BRN-GRY | 2P9-6, 7P1-18, 7P2-4 | Q45 | 904218-696* |
| 17 | ULP Jet Bumper | BLU-BRN | 2P12-7, 8P2-27 | Q2 | SG-23-850DC |
| 18 | ULP Right Side Kicker | BLU-RED | 2P12-4, 8P2-28 | Q4 | SA-23-850DC |
| 19 | Not Used | | | Q6 | |
| 20 | Not Used | | | Q8 | |
| 21 | Not Used | | | Q10 | |
| 22 | Not Used | | | Q12 | |
| | LLP Left Flipper | WHT-BRN | ULP, 8P5-18 | — | SFL-22-400/ 30-1000-DC |
| | LLP Right Flipper | WHT-ORN | ULP, 8P5-19 | — | SFL-22-400/ 30/1000-DC |
| | ULP Left Flipper | BLU-GRY | 2P12-2, 8P2-5 | — | SFL-19-400/ 30-750-DC |
| | ULP Right Flipper | BLU-VIO | 2P12-1, 8P2-4 | — | SFL-19-400 40-750-DC |

***NOTES:**

- Coin lockout part no. is a Coinco number.
- Special switch connections for solenoids 17 through 18 are as follows:
 17—ORN-BRN—2P13-5, 8P3-24
 18—ORN-RED—2P13-3, 8P3-25
- Flipper button connections are as follows:
 Right—ORN-VIO—2P12-1, 7P1-7
 Left—ORN-GRY—2P12-2, 7P1-9

4. Typical wiring for solenoids and special switches follows.

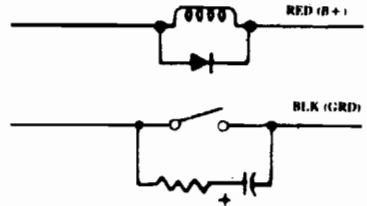

Switch Test

- From Solenoid Test depress ADVANCE with the switch set to AUTO-UP. Test 03 should be indicated in the Credits display and any stuck switches in the Master display. As stuck switch(es) is displayed a sound is produced. The display continuously cycles through the stuck switches and as they are opened, the number is removed from the sequence. When all switches are open, the Match display is blank and the sounds stop.
- If all switches in a row are displayed, first verify that all are open and then check for a short to ground on the row wire.
- Operate switches; a sound is produced and switch number is momentarily indicated in the ball in play display. If two switches in a row are indicated with one switch closed, check for a short between the column wires; for multiple indication check column wire for short to ground. If two switches in a column are indicated with one switch closed, check for short between row wires.

4. If proper indications are obtained in Test 03 but matrix problem is suspected in game play, disconnect lamp connectors 2P5 and 2P7. Recheck in game play. Perform CPU Self-Test if problem remains. If problem is cleared, check for short between lamp matrix and jet bumper mounting brackets.

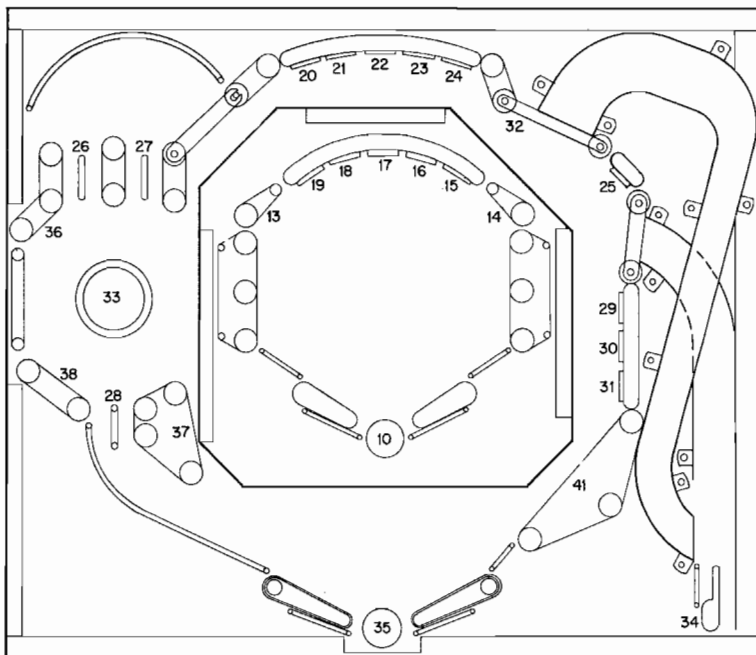

Switch

No. Function (Score)

| | | | |
|----|-------------------------------|-----|--|
| 01 | Plumb Bob Tilt, Cabinet | 25 | Bull's-Eye Target (100/25,000/Extra Ball when lit) LLP |
| 02 | Not Used | 26 | Lane A Rollover, ULP (1000) |
| 03 | 1-Player Start, Front Panel | 27 | Lane V Rollover, ULP (1000) |
| 04 | Right Coin Chute, Coin Door | 28 | Flipper Return Lane R Rollover (1000), ULP |
| 05 | Center Coin Chute, Coin Door | 29 | K Standup Target, ULP (1000) |
| 06 | Left Coin Chute, Coin Door | 30 | O Standup Target, ULP (1000) |
| 07 | Slam Tilt, Coin Door | 31 | N Standup Target, ULP (1000) |
| 08 | High Score Reset, Coin Door | 32 | Spinner (1000 w/lit, 100 w/not lit), ULP |
| 09 | 2-Player Start, Front Panel | 33 | Jet Bumper (lit value), ULP |
| 10 | Outhole/Eject, LLP | 34 | Ramp Chamber (lit value), ULP |
| 11 | Not Used | 35 | Outhole/Eject, ULP |
| 12 | Not Used | *36 | Top Left Standup Switch, ULP (10) |
| 13 | B Standup Target, LLP (1000) | *37 | Bottom Left Standup Switch, ULP (10) |
| 14 | A Standup Target, LLP (1000) | *38 | Center Left Standup Switch, ULP (10) |
| 15 | 6 Standup Target, LLP (1000) | 39 | Lane Change Right, Front Panel |
| 16 | 7 Standup Target, LLP (1000) | 40 | Lane Change Left, Front Panel |
| 17 | 8 Standup Target, LLP (1000) | *41 | Right Side Kicker, ULP (10) |
| 18 | 9 Standup Target, LLP (1000) | | |
| 19 | 10 Standup Target, LLP (1000) | | |
| 20 | 5 Standup Target, ULP (1000) | | |
| 21 | 4 Standup Target, ULP (1000) | | |
| 22 | 3 Standup Target, ULP (1000) | | |
| 23 | 2 Standup Target, ULP (1000) | | |
| 24 | 1 Standup Target, ULP (1000) | | |

NOTE:

LLP = Lower Level Playfield

ULP = Upper Level Playfield

*Left and right determinations are made with Playfield removed from game (**PLAY SIDE UP**) and flippers closest to observer.

Figure 4. Playfield Switch Locations and Switch Chart

| COLUMN ROW | 1 GRN-BRN 2J2-9 | 2 GRN-RED 2J2-8 | 3 GRN-ORN 2J2-7 | 4 GRN-YEL 2J2-6 | 5 GRN-BLK 2J2-5 | 6 GRN-BLU 2J2-3 | 7 GRN-VIO 2J2-2 | 8 GRN-GRY 2J2-1 |
|---------------------------|---|--|---|--|--|---|-----------------------|-----------------------|
| 1 WHT- BRN 2J3-9 | 1 Plumb Bob Tilt, Cabinet | 9 2-Player Start, Front Panel | 17 8 Standup Target, LLP (1000) | 25 Bull's-Eye Target (100/25,000/ Extra Ball when lift LLP | 33 Jet Bumper (lift value), ULP | 41 Right Side Kicker, ULP (10) | 49 | 57 |
| 2 WHT- RED 2J3-8 | 2 Not Used | 10 Outhole/Eject, LLP | 18 9 Standup Target, LLP (1000) | 26 Lane A Rollover, ULP (1000) | 34 Ramp Chamber (lift value), ULP | 42 | 50 | 58 |
| 3 WHT- ORN 2J3-7 | 3 1-Player Start, Front Panel | 11 Not Used | 19 10 Standup Target, LLP (1000) | 27 Lane V Rollover, ULP (1000) | 35 Outhole/Eject, ULP | 43 | 51 | 59 |
| 4 WHT- YEL 2J3-6 | 4 Right Coin Chute, Coin Door | 12 Not Used | 20 5 Standup Target, ULP (1000) | 28 Flipper Return Lane R Rollover (1000), ULP | 36 Top Left Standup Switch, ULP (10) | 44 | 52 | 60 |
| 5 WHT- GRN 2J3-5 | 5 Center Coin Chute, Coin Door | 13 B Standup Target, LLP (1000) | 21 4 Standup Target, ULP (1000) | 29 K Standup Target, ULP (1000) | 37 Bottom Left Standup Switch, ULP (10) | 45 | 53 | 61 |
| 6 WHT- BLU 2J3-4 | 6 Left Coin Chute, Coin Door | 14 A Standup Target, LLP (1000) | 22 3 Standup Target, ULP (1000) | 30 O Standup Target, ULP (1000) | 38 Center Left Standup Switch, ULP (10) | 46 | 54 | 62 |
| 7 WHT- VIO 2J3-3 | 7 Slam Tilt, Coin Door | 15 6 Standup Target, LLP (1000) | 23 2 Standup Target, ULP (1000) | 31 N Standup Target, ULP (1000) | 39 Lane Change Right, Front Panel | 47 | 55 | 63 |
| 8 WHT- GRY 2J3-1 | 8 High Score Reset, Coin Door | 16 7 Standup Target, LLP (1000) | 24 1 Standup Target, ULP (1000) | 32 Spinner (1000 w/lift 100 w/not lift) ULP | 40 Lane Change Left, Front Panel | 48 | 56 | 64 |

Figure 5. Switch Matrix

INITIATING AUTO-CYCLE MODE

1. Set AUTO-UP/MANUAL-DOWN switch to AUTO-UP and depress ADVANCE pushbutton. Test 04 is indicated in Credit display and Function 00 in Match Display.
2. Set switch to MANUAL-DOWN and depress ADVANCE to indicate Function 50 in the Match Display.
3. Set switch to AUTO-UP and operate Credit button to indicate 15 in Player 1 Display.
4. Depress ADVANCE pushbutton to start Auto-Cycle mode. Each cycle of this mode sequences thru the Display Digits Test, Sound Test (00), Lamp Test (01), and Solenoid test (02).
5. To terminate the test and return to game over, turn the game OFF and back ON.

CPU BOARD SELF-TEST

Depress the DIAGNOSTIC pushbutton on the left side of the CPU Board. The following indications are provided. With 0 indication the game returns to the game over mode.

- 0 - Test Passed
- 1 - IC13 RAM Faulty
- 2 - IC16 RAM Faulty
- 3 - IC17 ROM 2 Faulty
- 4 - IC17 ROM 2 Faulty
- 5 - IC20 ROM 1 Faulty
- 6 - IC14 Game ROM 1 Faulty
- 7 - IC26 Game ROM 0 Faulty
- 8 - IC19 CMOS RAM or Memory Protect Circuit Faulty
- 9 - Coin-door closed, Memory Protect Circuit Faulty, or IC19 CMOS RAM Faulty.

Note that "0" remaining after power turn-on indicates CPU Board lockup.

SOUND BOARD SELF-TEST

Depress DIAGNOSTIC pushbutton on the top of the Sound Board. Several electronic sounds should be produced. This sequence of sounds is repeated until the game is turned OFF and back ON.

Warning: This equipment generates, uses, and can radiate radio frequency energy and if not installed and used in accordance with the instructions manual, may cause interference to radio communications. As temporarily permitted by regulation it has not been tested for compliance pursuant to Subpart J of Part 15 of FCC Rules, which are designed to provide reasonable protection against such interference. Operation of this equipment in a residential area is likely to cause interference in which case the user at his own expense will be required to take whatever measures may be required to correct the interference.”

