

**KONAMI**®

**X-MEN**™

**4 PLAYER**

THE UNCANNY X-MEN and all Marvel characters: TM & copyright © 1992  
Marvel Entertainment Group, Inc. All Rights Reserved. © 1992 Konami.  
All Rights Reserved.

© Konami Inc. 1991 Konami® is a trademark of Konami Co., Ltd.

Service & Parts

**708-215-5100**

Jerry Korbecki (Service Manager) ext. 122

**INSTRUCTION MANUAL**

*KONAMI® is a trademark of Konami Industry Co., Ltd.*

# X-MEN 4 PLAYER PARTS LIST

---

Part #	Description
065011	DC Harness
065110	Control Panel Overlay
065111	Player Instruction Decal
065210	Marquee
065253	X-MEN 4 Player P.C.B.
065310	Upper Right Side Decal
065311	Upper Left Side Decal
065312	Middle Right Side Decal
065313	Middle Left Side Decal
065314	Lower Right Side Decal
065315	Lower Left Side Decal
065410	Instruction Manual
072010	AC Harness
30255	Red Micro Button
30256	Yellow Micro Button
30258	Blue Micro Button
30261	Micro Switch
30262	Palnut
30323	Red Joystick
30324	Blue Joystick
30325	Yellow Joystick
30328	Violet Joystick
35201	Isolation Transformer
35404	Power Supply
40356	Monitor Glass
40357	Marquee Glass
40524	25 Inch Monitor
40611	Monitor Bezel

# CONTROL PANEL ASSEMBLY

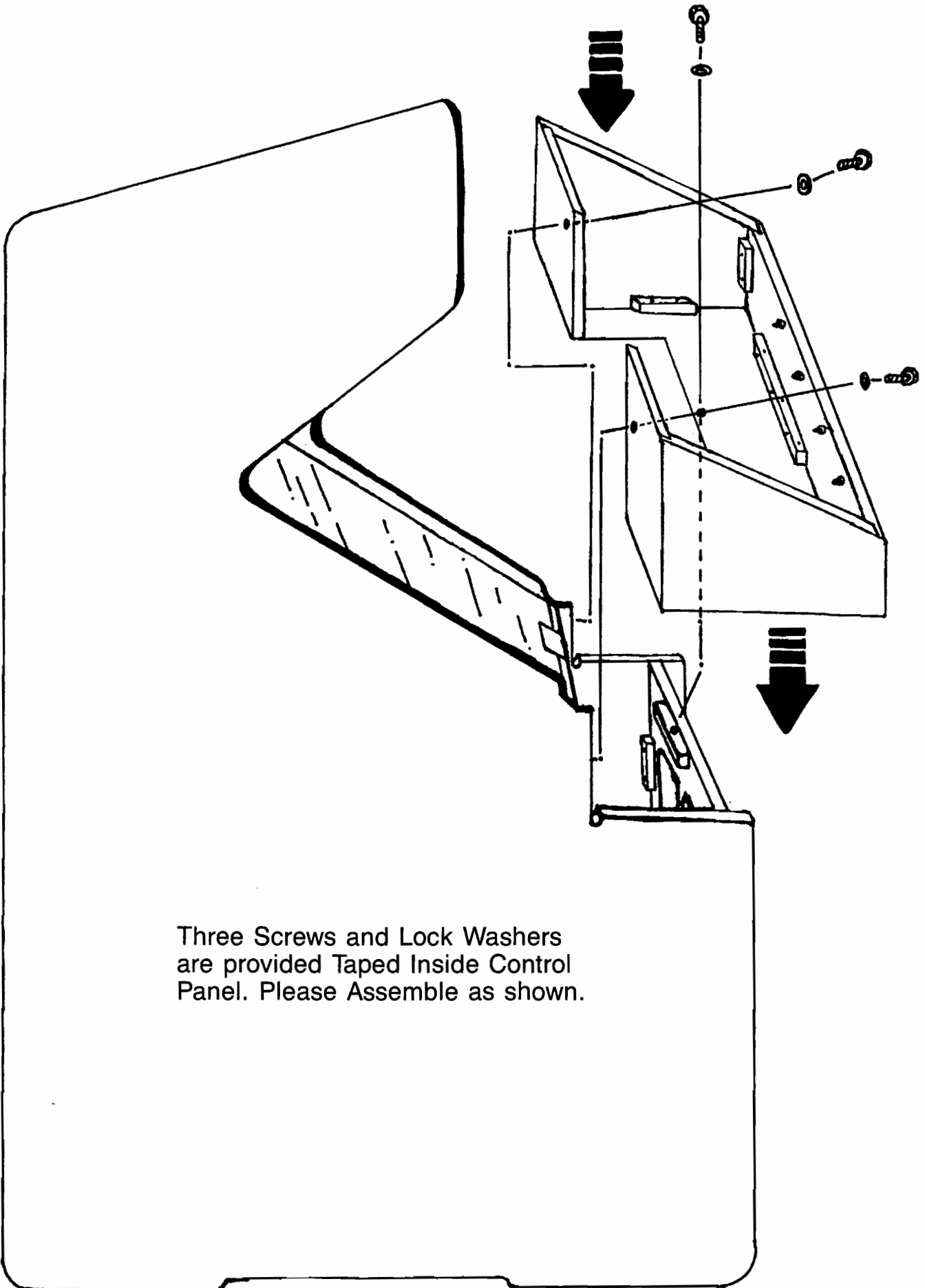

Three Screws and Lock Washers  
are provided Taped Inside Control  
Panel. Please Assemble as shown.

# X-MEN 4 PLAYER WIRING HARNESS

		← Solder Side	Parts Side →		
BLACK	GND	A	1	GND	BLACK
BLACK	GND	B	2	GND	BLACK
RED	+5V DC	C	3	+5V DC	RED
RED	+5V DC	D	4	+5V DC	RED
	NOT USED	E	5	NOT USED	
ORANGE	+12V DC	F	6	+12V DC	ORANGE
	*KEY	H	7	*KEY	
	(EMPTY)	J	8	COIN COUNTER	GREEN/VIOLET
	(EMPTY)	K	9	(EMPTY)	
	(EMPTY)	L	10	(EMPTY)	
	(EMPTY)	M	11	(EMPTY)	
WHITE/GREEN	VIDEO GREEN	N	12	VIDEO RED	RED/WHITE
WHITE	VIDEO SYNC	P	13	VIDEO BLUE	BLUE/WHITE
	(EMPTY)	R	14	VIDEO GROUND	BLACK
	(EMPTY)	S	15	TEST SWITCH	YELLOW
WHITE/VIOLET	COIN 2	T	16	COIN 1	BLUE/VIOLET
	NOT USED	U	17	NOT USED	
BLUE/YELLOW	2P UP	V	18	1P UP	ORANGE/WHITE
VIOLET/YELLOW	2P DOWN	W	19	1P DOWN	BLACK/WHITE
ORANGE/GREEN	2P LEFT	X	20	1P LEFT	RED/GRAY
ORANGE/YELLOW	2P RIGHT	Y	21	1P RIGHT	WHITE/GRAY
BLACK/YELLOW	2P ATTACK	Z	22	1P ATTACK	RED/WHITE
ORANGE/GRAY	2P JUMP	a	23	1P JUMP	GREEN/ORANGE
ORANGE	2P MUTANT POWER	b	24	1P MUTANT POWER	RED/BLUE
	NOT USED	c	25	NOT USED	
	NOT USED	d	26	NOT USED	
BLACK	GND	e	27	GND	BLACK
BLACK	GND	f	28	GND	BLACK

(BASE COLOR/LINE COLOR)

# X-MEN 4 PLAYER SUB HARNESS FOR 3 & 4 PLAYERS

<b>CN3</b> <b>3P</b> <b>CONTROLS</b>	1	Coin 3	Violet/White
	2	Empty	
	3	3P Left	White/Red
	4	3P Right	White/Yellow
	5	3P Up	White/Black
	6	3P Down	White/Blue
	7	3P Attack	White/Brown
	8	3P Jump	White/Orange
	9	3P Mutant Power	White
	10	Empty	
	11	Empty	
	12	Empty	
	13	Empty	
	14	Empty	
	15	Ground	Black

<b>CN4</b> <b>4P</b> <b>CONTROLS</b>	1	Coin 4	Blue
	2	Empty	
	3	4P Left	Yellow/Brown
	4	4P Right	Brown/Black
	5	4P Up	Yellow/Green
	6	4P Down	Yellow/Red
	7	4P Attack	Yellow/White
	8	4P Jump	Yellow/Blue
	9	4P Mutant Power	Yellow
	10	Empty	
	11	Empty	
	12	Empty	
	13	Empty	
	14	Empty	
	15	Ground	Black

# X-MEN 4 PLAYER TECHNICAL INFORMATION

---

## TECHNICAL INFORMATION

---

- (1) Required power capacity  
GND-Vcc 5V 5A or more  
GND-( + 12V)  
\*See the Wiring Diagram.
- (2) Output  
R (red) analog, positive  
G (green) analog, positive  
B (blue) analog, positive  
SYNC. H-V complexed, negative
- (3) There is no sound volume knob on the PCB. Sound level should be adjusted in the Manual Test mode. (See next page.)
- (4) Handle with care.

---

## PLAY INSTRUCTION

---

- 1 to 4 players can play at the same time.
- Choose the character you want to control out of the six individual X-MEN: Cyclops, Colossus, Wolverine, Storm, Nightcrawler and Dazzler.
- Deposit coins and the select screen will appear. Use the joystick to select character and press ATTACK, JUMP or MUTANT POWER button to decide and start the game.
- Control your character's movement using the 8-way joystick and attack enemies with ATTACK button. Press ATTACK button repeatedly to punch, kick, throw, back-attack the enemies. Use JUMP button to avoid enemy attack or defeat enemies from the air. Pressing JUMP button longer makes higher jump.
- Press ATTACK button while in the air for a flying attack.
- Press MUTANT POWER button to use a powerful Mutant Power of each individualistic character.
- Use of Mutant Power will consume 3 units of energy. When the energy left is less than 3 units, a power ball will be consumed instead. A bonus power ball can be obtained for defeating the boss enemy of each stage.
- Your energy will be consumed when attacked by enemies. When it is used up, you will lose one life. The game is over when you have lost all the lives.
- There are 8 stages in all. You can continue the game as many times as you want. Any player can join at any time.

---

## CABINET INFORMATION

---

- (1) Use a multi control upright cabinet with four sets of an 8-way joystick and three function buttons.
- (2) Four independent coin slots are necessary. Start buttons are substituted by the function buttons for each player. (If your cabinet is equipped with four start buttons, they also are effective to start the game.)  
\* If your PCB is "COMMON COIN MECHANISM" version, one or two coin slots are sufficient. In this case, four start buttons are necessary.

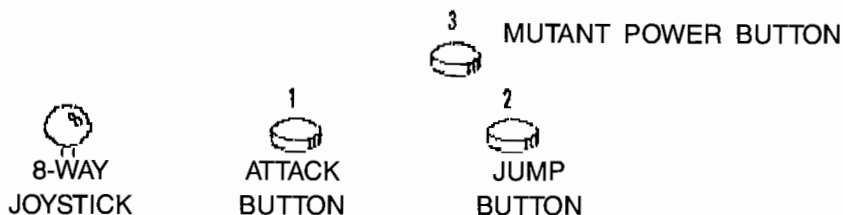

# X-MEN 4 PLAYER TECHNICAL INFORMATION (cont.)

---

## SELF TEST

---

Normal: "OK" will be displayed. Then the game will start.

Abnormal: "BAD" will be displayed and self test will repeat. If "13B BAD" is displayed, switch off and switch on again with TEST SWITCH (on the PCB) pressed.

---

## MANUAL TEST

---

### (1) HOW TO START

After switching on the power, press the TEST SWITCH on the PCB or on the cabinet, and you will get the MAIN MENU of the Manual Test.

NOTE: Switching on with TEST SWITCH pressed causes the program in the EEPROM to be initialized to default.

### (2) HOW TO RETURN TO THE GAME MODE

Select "EXIT" on the MAIN MENU then press player 1 ATTACK button to return to the game mode.

\*If your PCB is "COMMON COIN MECHANISM" version, use START button instead of ATTACK button.

### (3) ITEMS AND HOW TO SELECT

Use player 1 JOYSTICK to select the desired test and press player 1 ATTACK (START) button to initiate testing. Press player 1 ATTACK (START) button during or at the end of each test to return to the MAIN MENU.

I/O CHECK SCREEN CHECK COLOR CHECK SOUND CHECK MASK ROM CHECK GAME OPTIONS COIN OPTIONS EXIT  PLAYER1 JOYSTICK=SELECT ITEM PLAYER1 ATTACK/START=DO CHECK
--

### (4) EXPLANATION OF THE ITEMS

#### 1. I/O CHECK

Check all the joysticks and buttons to see "1" when switched on. Press player 1 and 2 ATTACK (START) buttons at the same time to return to MAIN MENU.

#### 2. SCREEN CHECK

Adjust focus, alignment, size, etc. using the cross-hatch screen.

#### 3. COLOR CHECK

Adjust color brightness so that the specified area will be colorless.

#### 4. SOUND CHECK

When "SOUND SCALE CHECK" is selected, a music scale sounds. At "SOUND CODE," push player 1 JOYSTICK right/left to change sound code.

#### 5. MASK ROM CHECK

Roms will be checked one after another, and the message "OK" or "BAD" will be displayed on the screen.

#### 6. GAME OPTIONS

Following screen will appear. Use player 1 JOYSTICK up/down to select the item and push JOYSTICK right/left to modify setting. Factory settings are shown in green and modified results in red. (Settings below are not always the factory settings.) After modification is completed, select "SAVE AND EXIT" and press player 1 ATTACK (START) button to save and return to MAIN MENU.

# X-MEN 4 PLAYER TECHNICAL INFORMATION (cont.)

GAME OPTIONS

PLAYER'S LIFE	1 CREDIT 3 LIVES
DIFFICULTY LEVEL	4/MEDIUM
MAXIMUM MUTANT POWER	9
VIDEO SCREEN FLIP	NORMAL
SOUND OUTPUT	STEREO
SOUND IN ATTRACT MODE	ALL THE TIME

SOUND VOLUME 

FACTORY SETTINGS  
 SAVE AND EXIT  
 EXIT

PLYR1 JOYSTICK UP/DOWN=SELECT OPTION  
 PLYR2 JOYSTICK RIGHT/LEFT=MODIFY SETTING

- ... Select from 1 to 9 lives.
- ... Select out of 8 levels.
- ... Maximum 9 or 3
- ... "NORMAL" or "UPSIDE DOWN"
- ... "STEREO" or "MONAURAL"
- ... Select out of 4 types: "ALL THE TIME," "COMPLETELY OFF," "ONCE EVERY 3 CYCLES" or "ONCE EVERY 5 CYCLES"
- ... Adjust volume level between 0 and 30.
- ... All the settings return to default.
- ... Save the modified settings.

\*If you select "EXIT" instead of "SAVE AND EXIT" after modifying some settings, the message appears; "YOU DID NOT SAVE. DO YOU WANT TO SAVE? YES/NO." When you choose "YES," the screen shows "NOW SAVING" and returns to MAIN MENU. If you select "NO," "NO MODIFICATION" is shown and then MAIN MENU appears.

## (7) COIN OPTIONS

Selecting this item, the screen shows the following options.

COIN OPTIONS

PREMIUM START	YES 1
STARTING	2 COINS 1 CREDIT
CONTINUATION	1 COIN 1 CREDIT

FACTORY SETTINGS  
 SAVE AND EXIT  
 EXIT

PLYR1 JOYSTICK UP/DOWN=SELECT OPTION  
 PLYR2 JOYSTICK RIGHT/LEFT=MODIFY SETTING

... "NO" or "YES 1" to "YES 4" (The number means the EXTRA coins necessary.)

} Same as above "GAME OPTIONS"



# X-MEN 4 PLAYER TECHNICAL INFORMATION (cont.)

When you want "PREMIUM START" setting, choose the number of extra coins necessary for starting, then decide the coin setting for continuation. The number of coins for starting will be the sum of both numbers. If you do not set premium start, the number of coins necessary for starting and continuation will be the same.

\* If your PCB is "COMMON COIN MECHANISM" version, the screen will be as follows. On the cabinet with two coin slots, coin setting must be done for each coin slot.

COIN OPTIONS

FREE PLAY	NO
COIN SLOT 1	1 COIN 1 CREDIT
COIN SLOT 2	1 COIN 1 CREDIT
FACTORY SETTINGS	
SAVE AND EXIT	
EXIT	
PLYR1 JOYSTICK UP/DOWN=SELECT OPTION	
PLYR2 JOYSTICK RIGHT/LEFT=MODIFY SETTING	

} Same as "GAME OPTIONS"

## \*COIN SETTING OPTIONS

COIN(S)	1	1	1	1	1	1	1	2	2	2	3	3	3	4	4	4
CREDIT(S)	1	2	3	4	5	6	7	1	3	5	1	2	4	1	3	5

# X-MEN 4 PLAYER A.C. WIRING HARNESS

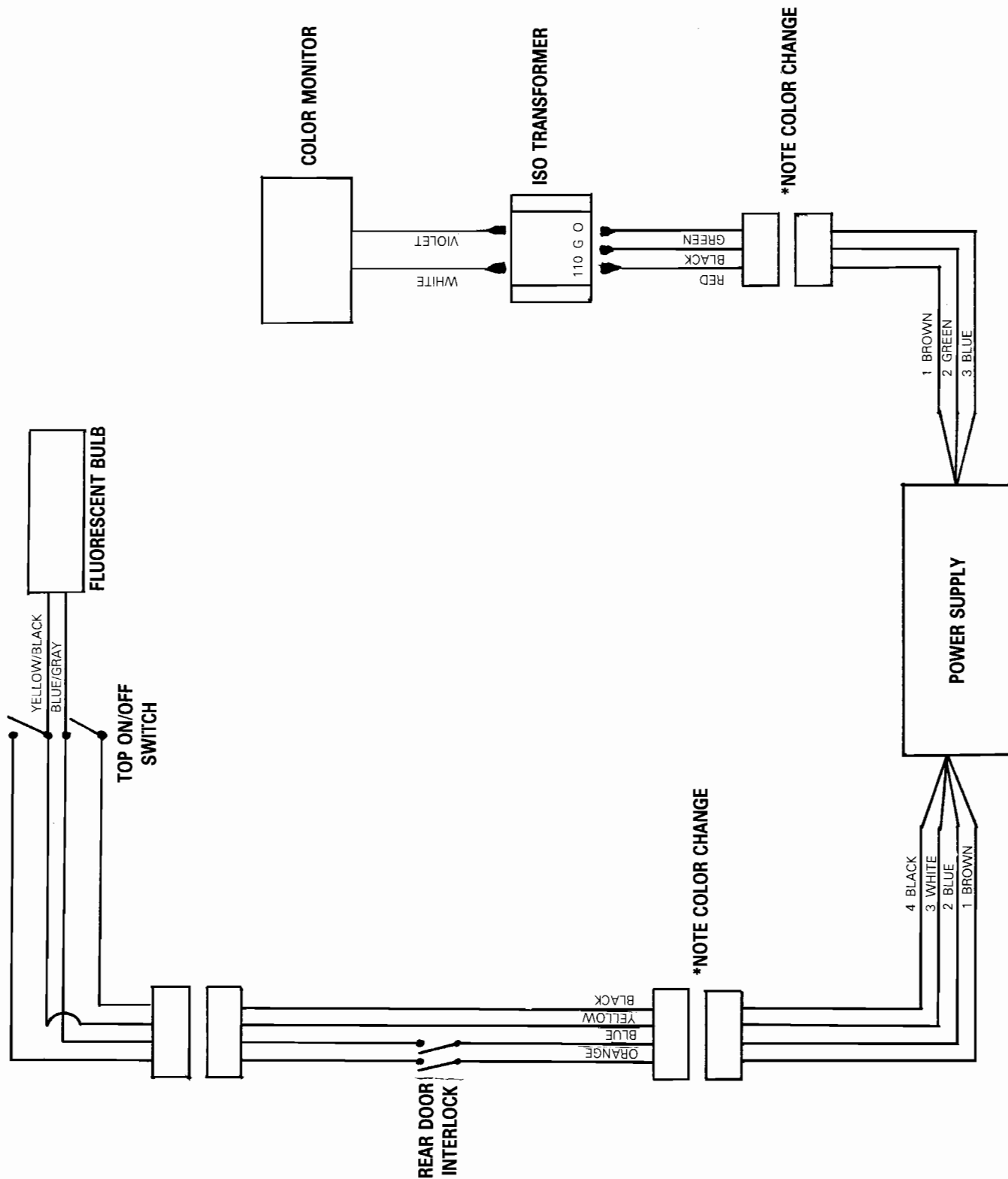

# X-MEN 4 PLAYER PCB LAYOUT

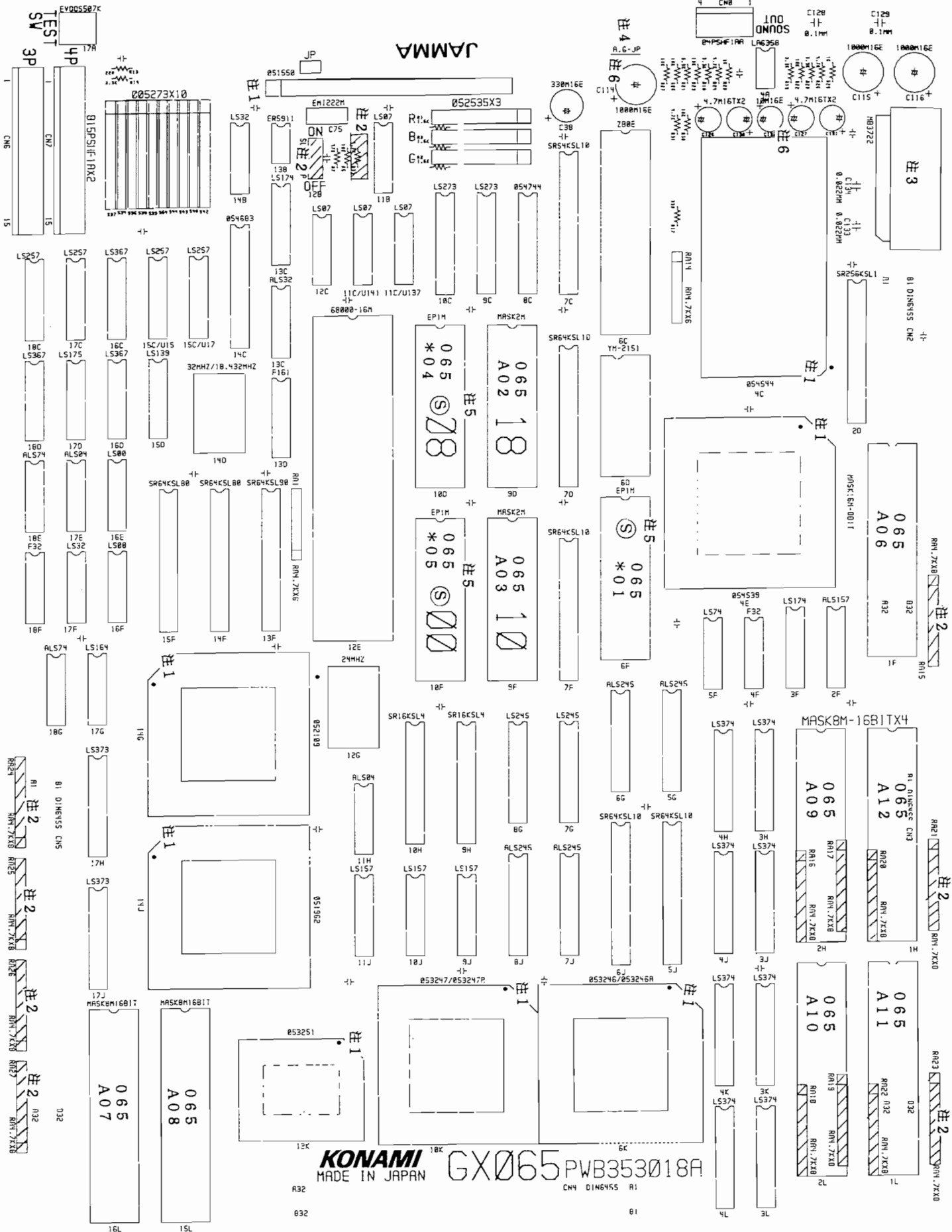

# X-MEN 4 PLAYER WIRING DIAGRAM

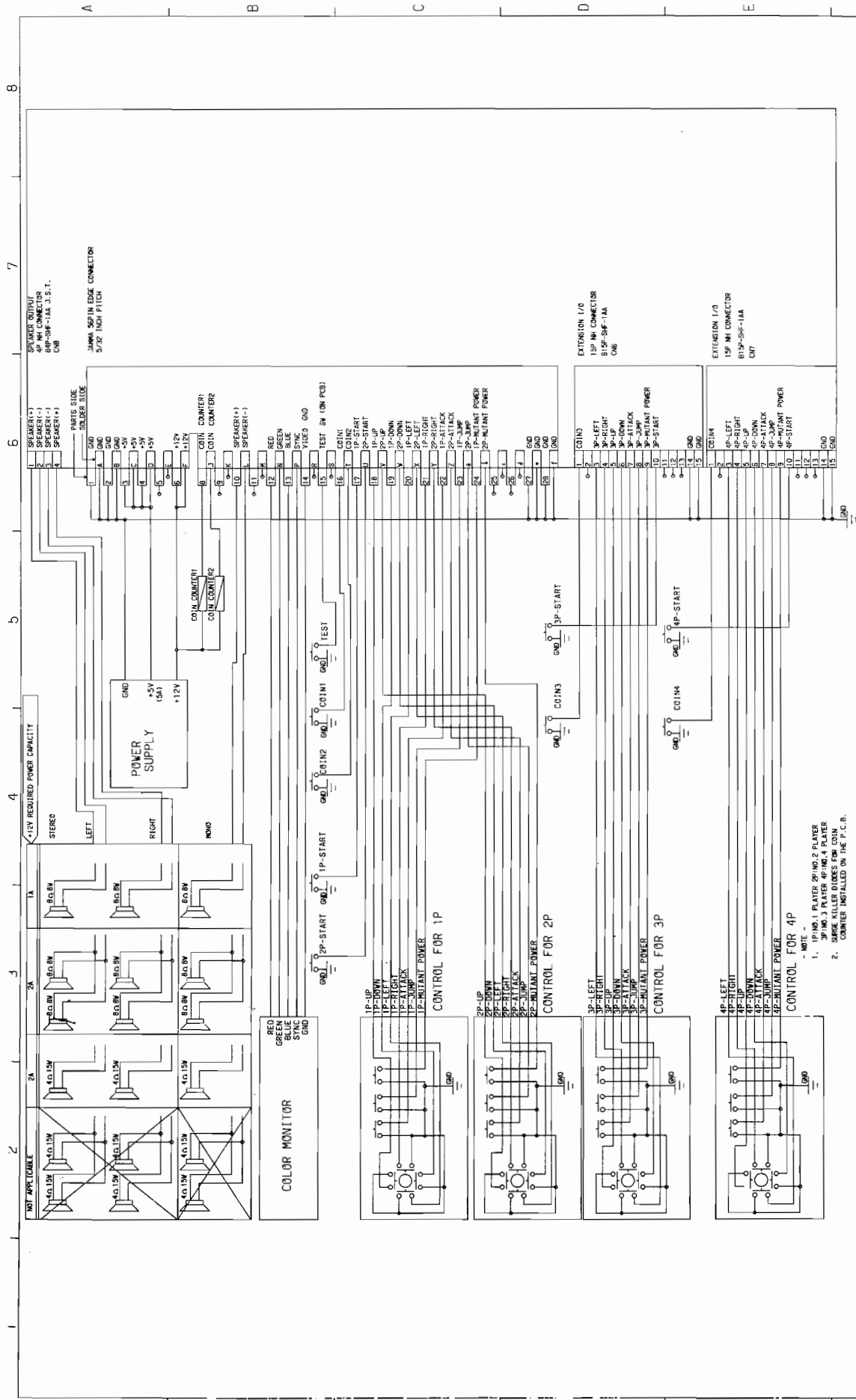

DESIGN	TITLE	WIRING DIAGRAM
H. MATSUURA	6X065	
DRW	6X065	
CHECK	PAGE	1/1
APPROVE	CODE NO.	353133
SCALE	REG. TYPE	6X065-UE
TOLERANCE	SECURITY LEVEL	NORMAL
DATE	DATE	1992. 2. 12.

**PROPRIETARY AND CONFIDENTIAL:**  
 THIS DOCUMENT IS THE PROPERTY OF KONAMI CO., LTD. NO PART OF THIS DOCUMENT IS TO BE REPRODUCED OR TRANSMITTED IN ANY FORM OR BY ANY MEANS, ELECTRONIC OR MECHANICAL, INCLUDING PHOTOCOPYING, RECORDING, OR BY ANY INFORMATION STORAGE AND RETRIEVAL SYSTEM, WITHOUT THE WRITTEN PERMISSION OF KONAMI CO., LTD. THIS DOCUMENT IS THE PROPERTY OF KONAMI CO., LTD. AND FOR MANUFACTURE UNDER LICENSE FROM KONAMI CO., LTD. ANY REPRODUCTION OR TRANSMISSION OF THIS DOCUMENT WITHOUT THE WRITTEN PERMISSION OF KONAMI CO., LTD. IS STRICTLY PROHIBITED. THE PRINTED CIRCUIT BOARD OR OPERATING MANUAL RELATING THERETO, WHATSOEVER, UNLESS BY WRITTEN AGREEMENT WITH OR WRITTEN PERMISSION FROM KONAMI. COPYRIGHT 1991 KONAMI CO., LTD. ALL RIGHTS RESERVED.

KONAMI CO., LTD.

DESIGN: H. MATSUURA  
 DRAW: H. MATSUURA  
 CHECK: H. MATSUURA  
 APPROVE: H. MATSUURA  
 SCALE: H. MATSUURA  
 TOLERANCE: H. MATSUURA  
 DATE: 1992. 2. 12.

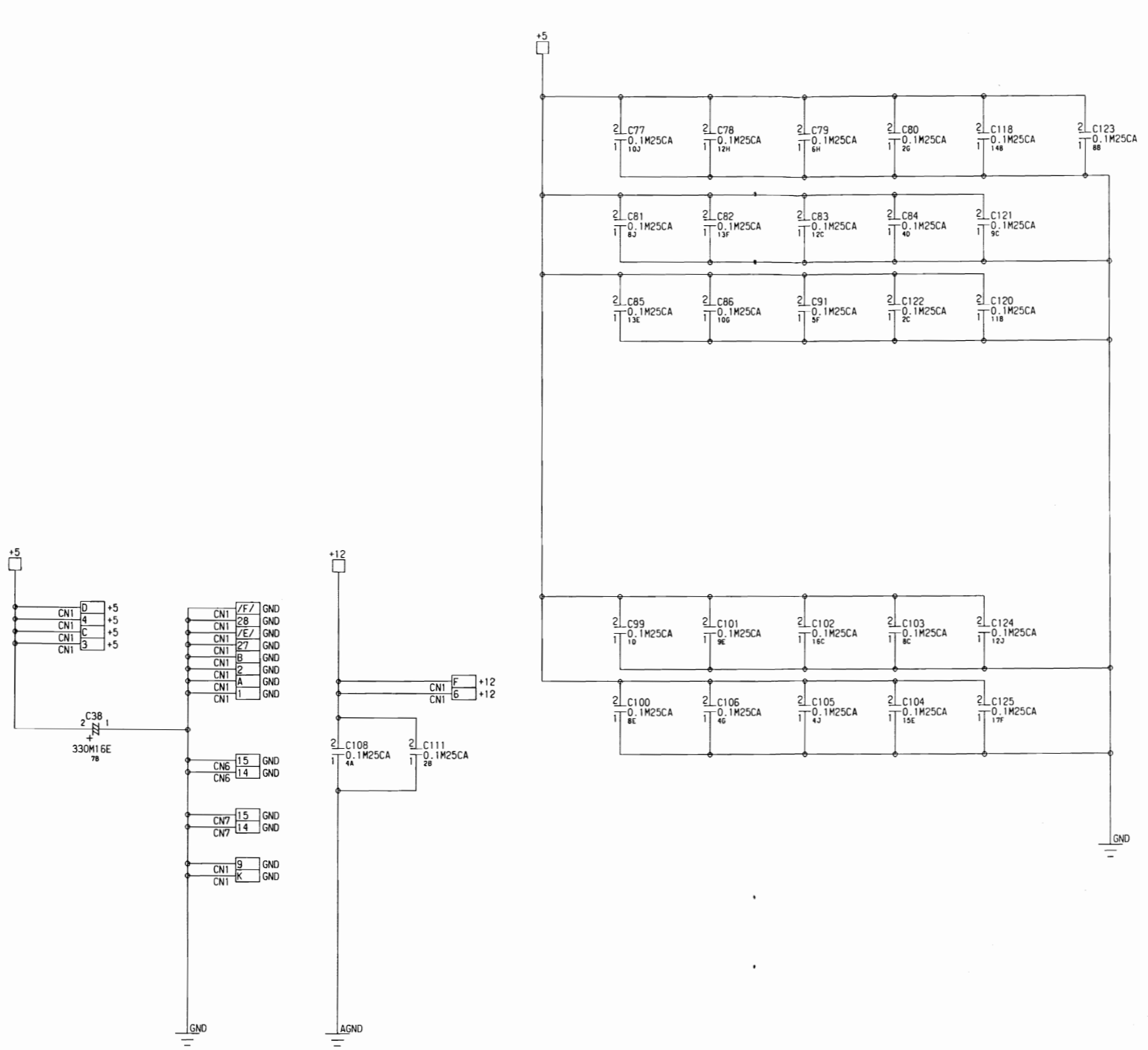

- 88 CN8 B4P-SHF-1AA
- 88 CN7 B15P-SHF-1AA
- 88 CN6 B15P-SHF-1AA
- 88 CN5 DIN64SS
- 88 CN4 DIN64SS
- 88 CN3 DIN64SS
- 88 CN2 DIN64SS
- 88 CN1 JAMMA

**PROPRIETARY AND CONFIDENTIAL:**  
 REPRODUCTION FORBIDDEN WITHOUT THE SPECIFIC WRITTEN PERMISSION OF KONAMI CO.,LTD..7-3-2.  
 MINATOJIMA-NAKAMACHI, CHUO-KU, KOBE 650, JAPAN. THIS DRAWING IS ONLY CONDITIONALLY ISSUED. NEITHER  
 RECEIPT NOR POSSESSION OF THIS DRAWING OR ANY OPERATING MANUAL RELATING TO KONAMI'S GAMES OR PRODUCTS  
 CONTAINING THIS DRAWING CONFERS OR TRANSFERS ANY RIGHT IN OR LICENSE TO USE THE PRINTED CIRCUIT BOARDS  
 RELATING TO THIS DRAWING OR OTHER SUBJECT MATTER OF THE DRAWING OR ANY DESIGN OR TECHNICAL INFORMATION  
 SHOWN THEREON. EXCEPT FOR MANUFACTURE BY VENDORS OF KONAMI CO.,LTD. AND FOR MANUFACTURE UNDER  
 KONAMI'S WRITTEN LICENSE. NO RIGHT IS GRANTED TO REPRODUCE, MAKE, HAVE MADE, USE OR SELL THIS DRAWING  
 OR THE SUBJECT MATTER THEREOF INCLUDING, WITHOUT LIMITATION, THE PRINTED CIRCUIT BOARD OR OPERATING MANUAL  
 RELATING THERETO. WHATSOEVER, UNLESS BY WRITTEN AGREEMENT WITH OR WRITTEN PERMISSION FROM KONAMI.  
 COPYRIGHT 1991 KONAMI CO.,LTD. ALL RIGHTS RESERVED.

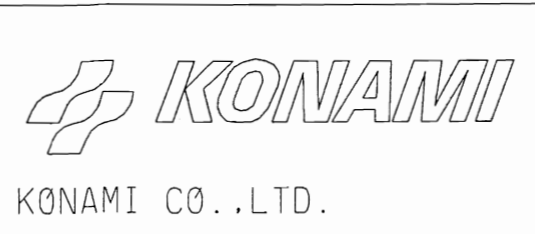

DRAWING	DESIGN	H. MATSUURA	TITLE	SCHEMATIC DIAGRAM
	DRAW	H. MATSUURA	SUBTITLE	70POWER
	CHECK	<i>H. Matsuura</i>	PAGE	
	APPROVE	<i>H. Matsuura</i>	CODE NO.	353106A
	SCALE		REG. TYPE	GX065 PWB353018A
	TOLERANCE		SECURITY LEVEL	CONFIDENTIAL
	DATE	1992. 2.27		

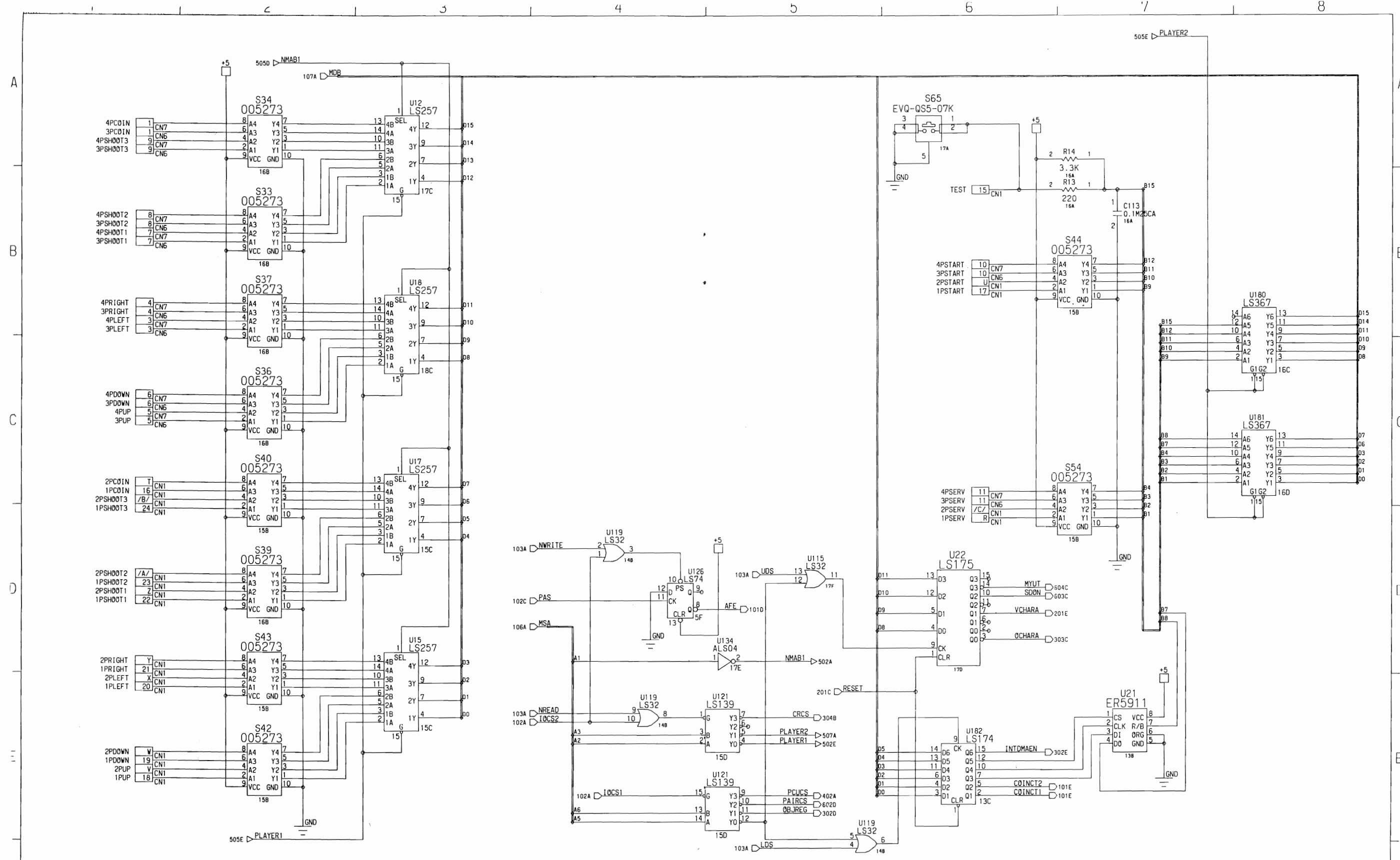

**PROPRIETARY AND CONFIDENTIAL:**  
 REPRODUCTION FORBIDDEN WITHOUT THE SPECIFIC WRITTEN PERMISSION OF KONAMI CO., LTD., 7-3-2, MINATOJIMA-NAKAMACHI, CHUO-KU, KOBE 650, JAPAN. THIS DRAWING IS ONLY CONDITIONALLY ISSUED. NEITHER RECEIPT NOR POSSESSION OF THIS DRAWING OR ANY OPERATING MANUAL RELATING TO KONAMI'S GAMES OR PRODUCTS CONTAINING THIS DRAWING CONFERS OR TRANSFERS ANY RIGHT IN OR LICENSE TO USE THE PRINTED CIRCUIT BOARDS RELATING TO THIS DRAWING OR OTHER SUBJECT MATTER OF THE DRAWING OR ANY DESIGN OR TECHNICAL INFORMATION SHOWN THEREON, EXCEPT FOR MANUFACTURE BY VENDORS OF KONAMI CO., LTD. AND FOR MANUFACTURE UNDER KONAMI'S WRITTEN LICENSE. NO RIGHT IS GRANTED TO REPRODUCE, MAKE, HAVE MADE, USE OR SELL THIS DRAWING OR THE SUBJECT MATTER THEREOF INCLUDING, WITHOUT LIMITATION, THE PRINTED CIRCUIT BOARD OR OPERATING MANUAL RELATING THERETO, WHATSOEVER, UNLESS BY WRITTEN AGREEMENT WITH OR WRITTEN PERMISSION FROM KONAMI. COPYRIGHT 1991 KONAMI CO., LTD. ALL RIGHTS RESERVED.



DRAWING	DESIGN	H. MATSUURA	TITLE	SCHEMATIC DIAGRAM
	DRAW	H. MATSUURA	SUBTITLE	501/0
	CHECK	<i>[Signature]</i>	PAGE	
	APPROVE	<i>[Signature]</i>	CODE NO.	353106A
	SCALE		REG. TYPE	GX065 PWB353018A
	TOLERANCE		SECURITY LEVEL	CONFIDENTIAL
	DATE	1992. 2.27		

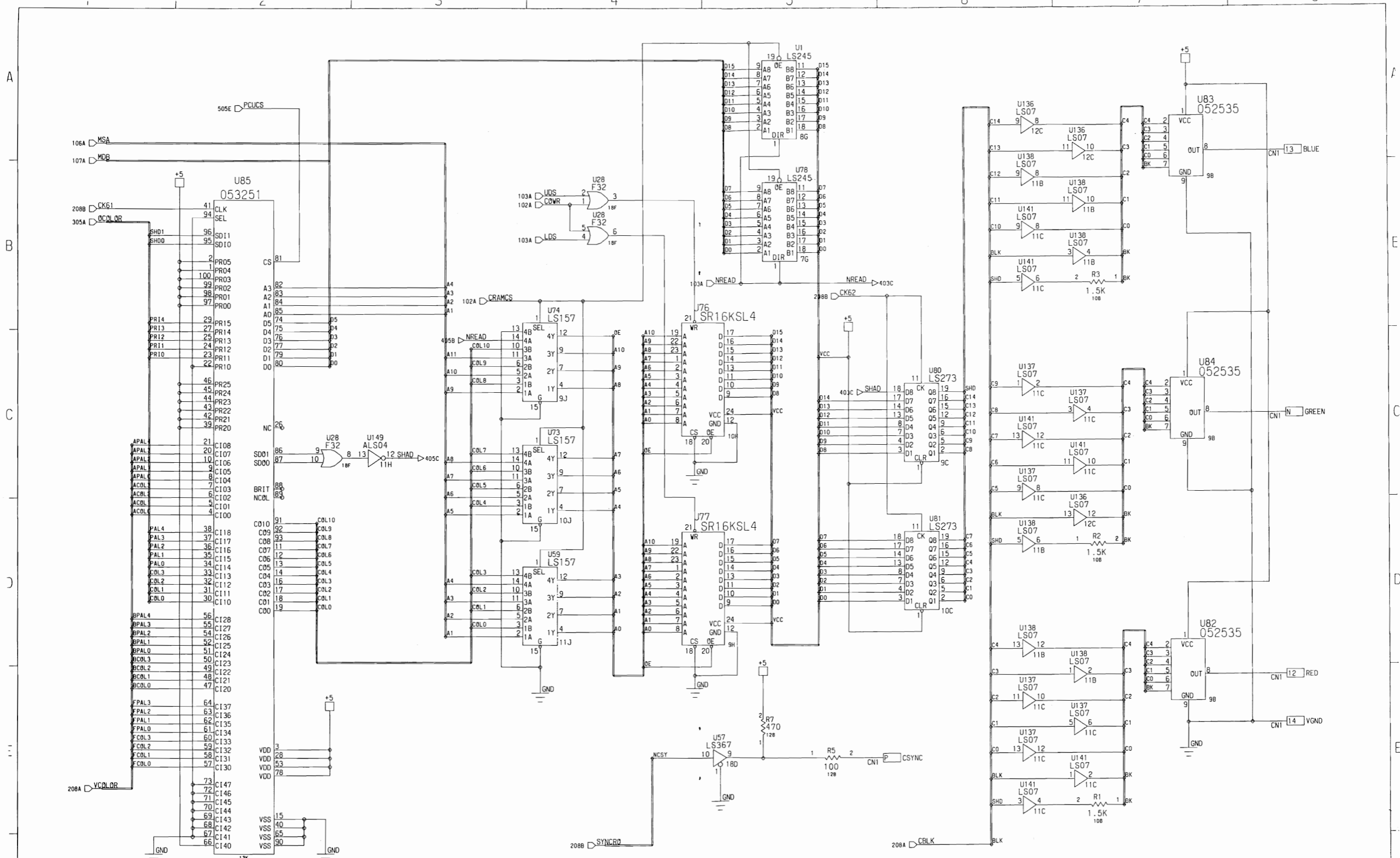

PROPRIETARY AND CONFIDENTIAL:  
 REPRODUCTION FORBIDDEN WITHOUT THE SPECIFIC WRITTEN PERMISSION OF KONAMI CO.,LTD. 7-3-2.  
 MINATOJIMA-NAKAMACHI, CHUO-KU, KOBE 650, JAPAN. THIS DRAWING IS ONLY CONDITIONALLY ISSUED. NEITHER  
 RECEIPT NOR POSSESSION OF THIS DRAWING OR ANY OPERATING MANUAL RELATING TO KONAMI'S GAMES OR PRODUCTS  
 CONTAINING THIS DRAWING CONFERS OR TRANSFERS ANY RIGHT IN OR LICENSE TO USE THE PRINTED CIRCUIT BOARDS  
 RELATING TO THIS DRAWING OR OTHER SUBJECT MATTER OF THE DRAWING OR ANY DESIGN OR TECHNICAL INFORMATION  
 SHOWN THEREON, EXCEPT FOR MANUFACTURE BY VENDORS OF KONAMI CO.,LTD. AND FOR MANUFACTURE UNDER  
 KONAMI'S WRITTEN LICENSE. NO RIGHT IS GRANTED TO REPRODUCE, MAKE, HAVE MADE, USE OR SELL THIS DRAWING  
 OR THE SUBJECT MATTER THEREOF INCLUDING, WITHOUT LIMITATION, THE PRINTED CIRCUIT BOARD OR OPERATING MANUAL  
 RELATING THERETO, WHATSOEVER, UNLESS BY WRITTEN AGREEMENT WITH OR WRITTEN PERMISSION FROM KONAMI.  
 COPYRIGHT 1991 KONAMI CO.,LTD. ALL RIGHTS RESERVED.



DRAWING		DESIGN	H. MATSUURA	TITLE	SCHEMATIC DIAGRAM
DRAW			H. MATSUURA	SUBTITLE	40COLOR
CHECK			<i>H. Matsuura</i>	PAGE	
APPROVE			<i>H. Matsuura</i>	CODE NO.	353106A
SCALE				REG. TYPE	GX065 PWB353018A
TOLERANCE				SECURITY LEVEL	CONFIDENTIAL
DATE					1992. 2.27

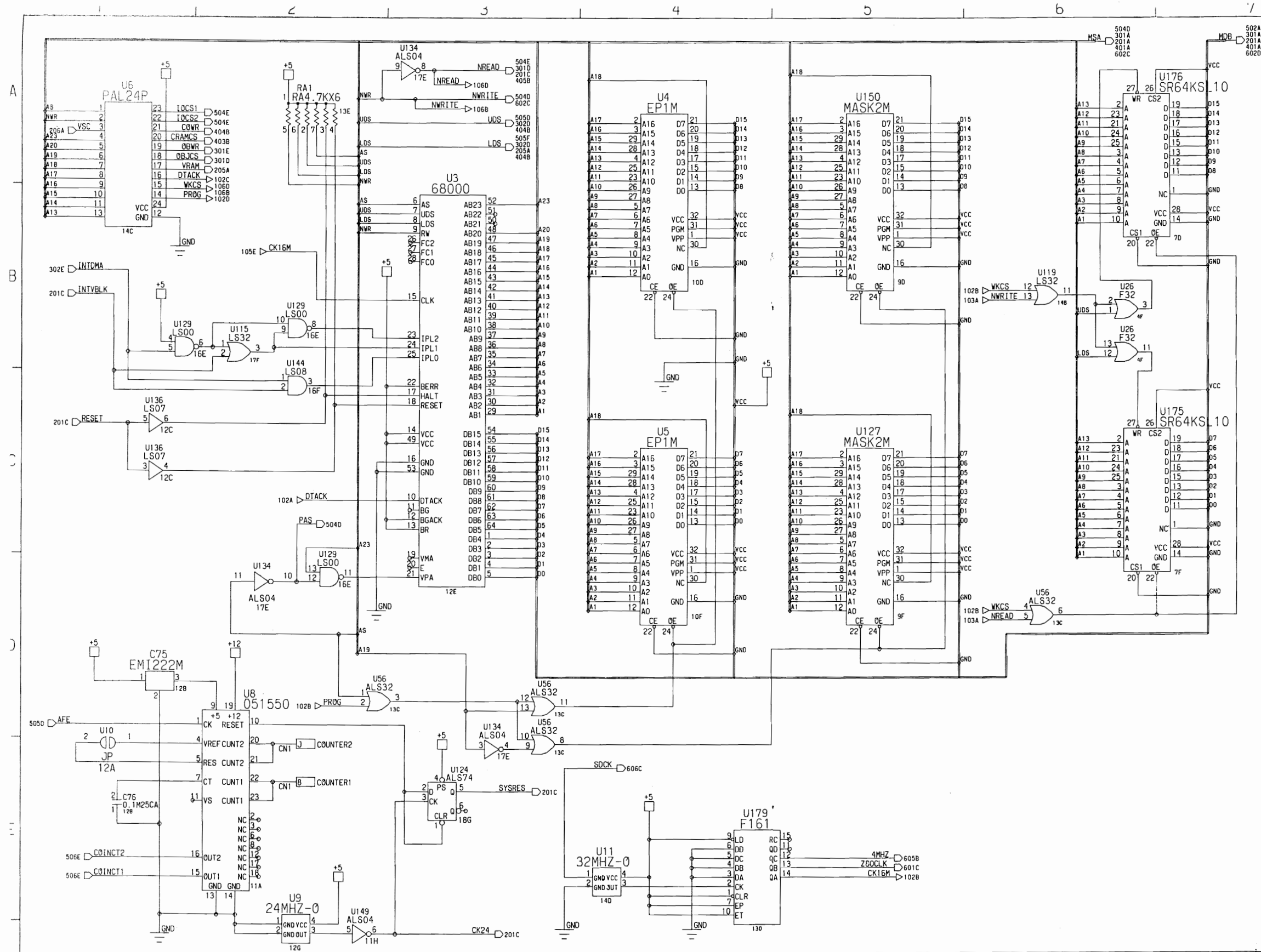

---NOTES---

- VCC (+5V)
- VCC (+12V)
- GND

- JAMMA EDGE 56P
- 64P DIN CONNECTOR
- 64P DIN CONNECTOR
- 64P DIN CONNECTOR
- 64P DIN CONNECTOR
- 15P NH CONNECTOR
- 15P NH CONNECTOR
- 4P NH CONNECTOR

KINDS OF CAPACITOR

- C : CERAMIC
- E : ELECTROLYTIC
- M : MYLAR
- T : TANTALUM

PROPRIETARY AND CONFIDENTIAL :  
 REPRODUCTION FORBIDDEN WITHOUT THE SPECIFIC WRITTEN PERMISSION OF KONAMI CO.,LTD..7-3-2.  
 MINATOJIMA-NAKAMACHI, CHUO-KU, KOBE 650, JAPAN. THIS DRAWING IS ONLY CONDITIONALLY ISSUED. NEITHER  
 RECEIPT NOR POSSESSION OF THIS DRAWING OR ANY OPERATING MANUAL RELATING TO KONAMI'S GAMES OR PRODUCTS  
 CONTAINING THIS DRAWING CONFERS OR TRANSFERS ANY RIGHT IN OR LICENSE TO USE THE PRINTED CIRCUIT BOARDS  
 RELATING TO THIS DRAWING OR OTHER SUBJECT MATTER OF THE DRAWING OR ANY DESIGN OR TECHNICAL INFORMATION  
 SHOWN THEREON. EXCEPT FOR MANUFACTURE BY VENDORS OF KONAMI CO.,LTD. AND FOR MANUFACTURE UNDER  
 KONAMI'S WRITTEN LICENSE. NO RIGHT IS GRANTED TO REPRODUCE, MAKE, HAVE MADE, USE OR SELL THIS DRAWING  
 OR THE SUBJECT MATTER THEREOF INCLUDING, WITHOUT LIMITATION, THE PRINTED CIRCUIT BOARD OR OPERATING MANUAL  
 RELATING THERETO. WHATSOEVER, UNLESS BY WRITTEN AGREEMENT WITH OR WRITTEN PERMISSION FROM KONAMI.  
 COPYRIGHT 1991 KONAMI CO.,LTD. ALL RIGHTS RESERVED.



DRAWING	DESIGN	H. MATSUURA	TITLE	SCHEMATIC DIAGRAM
	DRAW	H. MATSUURA	SUBTITLE	10CPU
	CHECK	<i>H. Hashima</i>	PAGE	
	APPROVE	<i>K. Iwano</i>	CODE NO.	353106A
	SCALE		REG. TYPE	GX065 PWB353018A
	TOLERANCE		SECURITY LEVEL	CONFIDENTIAL
	DATE	1992. 2.27		



THIS EQUIPMENT COMPLIES WITH THE REQUIREMENTS IN PART 15 OF FCC RULES FOR A CLASS A COMPUTING DEVICE. OPERATION OF THIS EQUIPMENT IN A RESIDENTIAL AREA MAY CAUSE UNACCEPTABLE INTERFERENCE TO RADIO AND TV RECEPTION REQUIRING THE OPERATOR TO TAKE WHATEVER STEPS ARE NECESSARY TO CORRECT THE INTERFERENCE. THIS DEVICE MUST ACCEPT ANY INTERFERENCE RECEIVED, INCLUDING INTERFERENCE THAT MAY CAUSE UNDESIREED OPERATION.

***KONAMI***®