



900-00001-01 Rework kit
Fast and The Furious Drift

SERVICE BULLETIN

Importance: High

Models Affected: "The Fast and the Furious DRIFT" S/N 1000 – 3477, and "The Fast and The Furious" S/N 7576-8275

Raw Thrills has identified a potential issue associated with certain games manufactured in the United States. As a result, Raw Thrills is issuing an upgrade kit to prevent any problems from arising with these games. Under rare conditions, it is possible for a PCB inside the game to develop a short that could lead to extreme overheating or fire.

Continued operation of this game without performing the necessary inspection and rework may result in an eventual fire hazard.

Cause: Improper standoffs were installed on a range of our PCB's. Over-tightening during game assembly compressed these standoffs, leading to increased stress on the board and, in rare cases due to shock from transport or placement, fracture. The board fracture then introduces shorts and low-impedance circuits between 5V and GND.

Remedy: Relieve over-tightening and replace standoffs if necessary; add fuse-holder (for general improved protection against over-current situations).

For Additional Assistance Please Contact Betson Enterprises at 1-800-753-2513

Once you have successfully completed updating your The Fast and The Furious Drift, or The Fast and The Furious game, please complete and return the form below using the enclosed pre-paid postage envelope.

Company Name _____

Print Name _____

Serial Number _____

- Circle Game Model -

The Fast and The Furious Drift

The Fast and The Furious

Signature _____

**900-00001-01 Rework kit
Fast and The Furious Drift**

Upgrade Procedure (about 15 minutes to complete)

Tools required:

- **Philips-head screwdriver or ¼" hex driver**
- **Pliers**

1. Disconnect power on the game. Failure to fully disconnect power from the game before servicing could lead to injury or death.
2. Remove the screws (if any) from the back door of the game.
3. Unlock the back door of the game. Games ship from the factory with the back door key located on a hook on the coin door.
4. Locate the power supply in the lower-left part of the cabinet and find the 12-pin and 4-pin AMP connectors coming from it (see figure below)

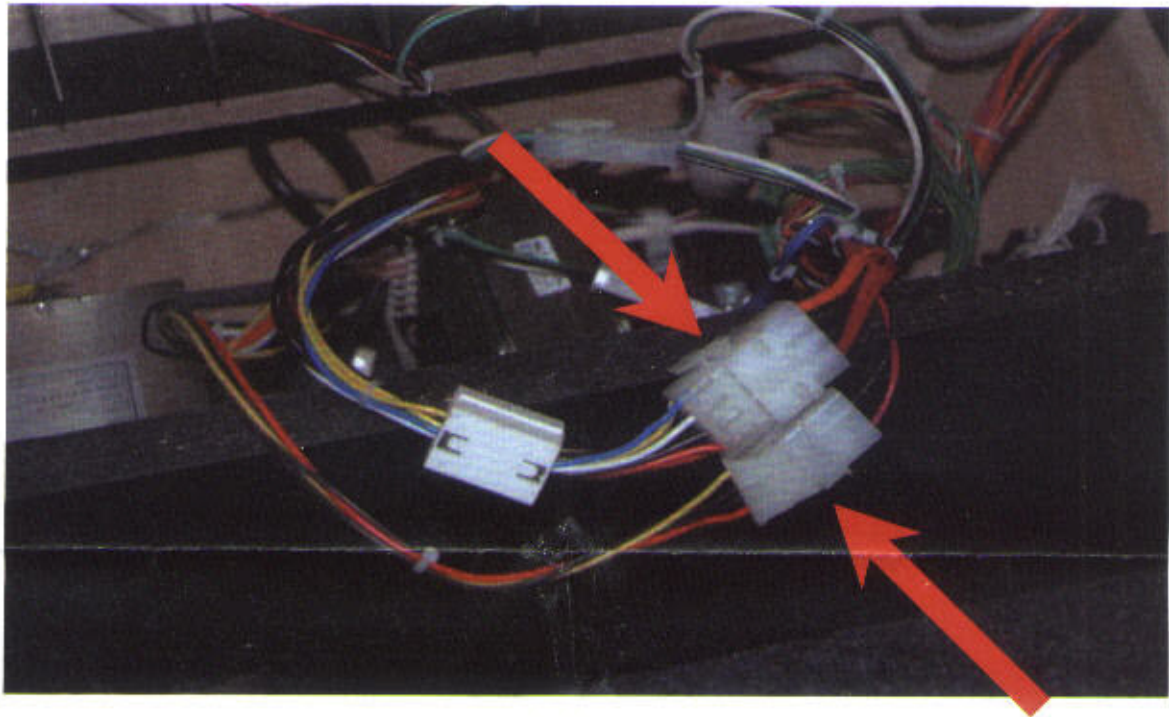

Betson Enterprises
A Division of H. Betti Industries, Inc.
303 Paterson Plank Road
Carlstadt, N.J. 07072-2307

**900-00001-01 Rework kit
Fast and The Furious Drift**

5. Disconnect both connectors.
6. Connect the fuseholder assembly in between the power supply and system harness via the 12-pin connectors. Then, connect **ONLY THE SYSTEM SIDE** of the 4-pin connector, leaving the power-supply side free (see figure below)

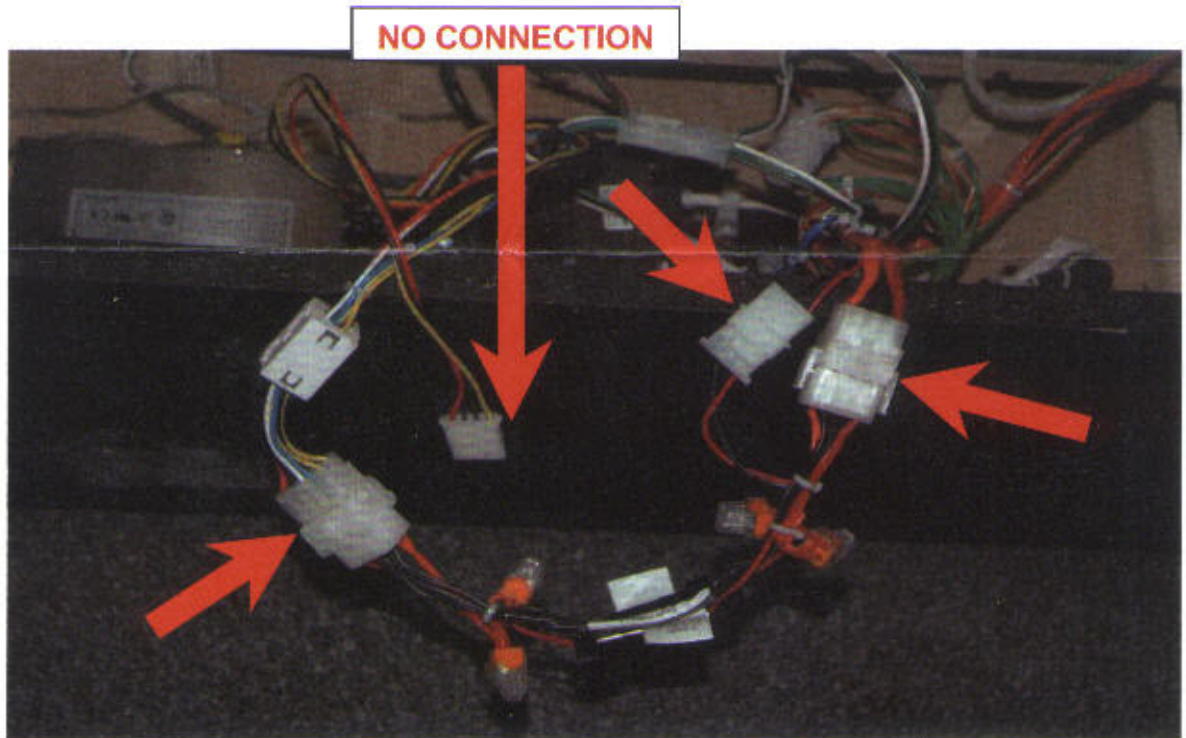

7. Connect the 4-pin connector on the fuseholder assembly to the system harness.
8. Locate the I/O board (for Drift / for FnF)
9. Visually inspect the corners of the board for fractures or bowing. **If the board is fractured, remove and contact Betson for an immediate replacement at 1-800-753-2513.**
10. Loosen the screws to relieve pressure on the board.
11. Replace the standoffs with the standoffs enclosed in the kit, if necessary.
12. Replace the back door and securely fasten.
13. Reconnect power.