

namco[®]

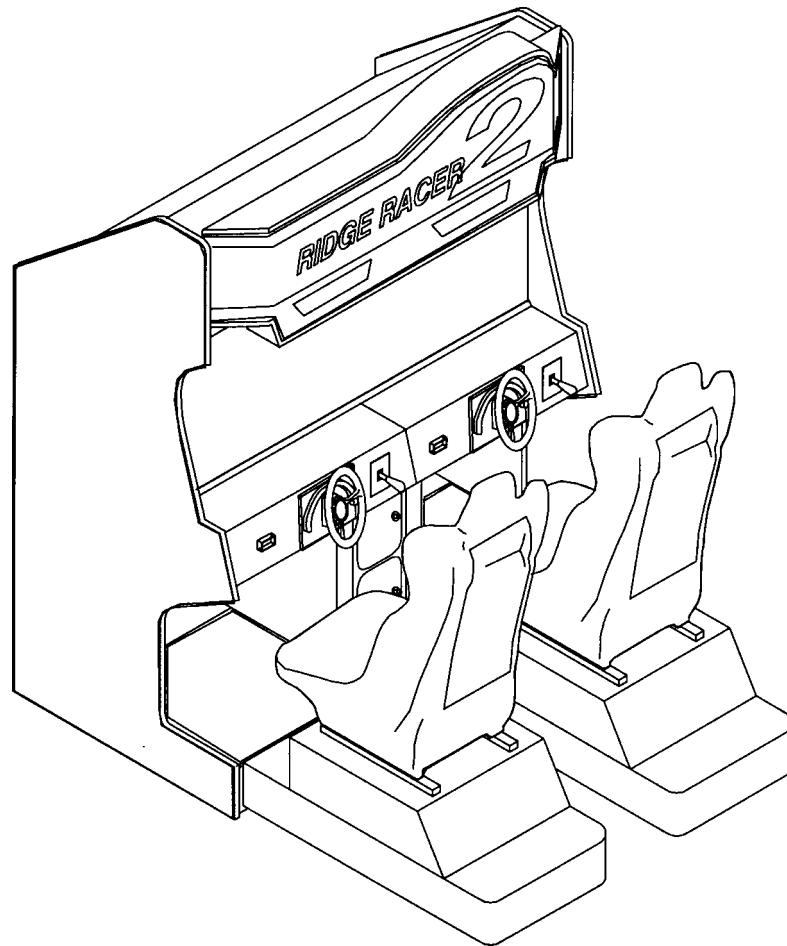

RIDGE RACER **2**

Operators Manual

Part No 90500075

© 1993,1994 **namco** Ltd - all rights reserved.

No part of this publication may be reproduced by any mechanical, photographic or electronic process, or in the form of phonographic recording, nor may it be stored in a retrieval system, transmitted or otherwise copied for public or private use, without permission from **namco** Ltd.

While the information contained in this manual is given in good faith and was accurate at the time of publication, BRENT LEISURE LIMITED reserve the right to make changes and alterations without notice.

No responsibility is accepted for unauthorized changes or modifications made to the machine.

Published by:
BRENT LEISURE Ltd.
Unit 1 Brent Crescent,
London. NW10 0QT

Phone:- 081-965-0550
Fax:- 081-961-0574

Contents

Operators Manual	1
1. SPECIFICATIONS	5
2. MAJOR COMPONENTS	6
3. PRECAUTIONS	7
3-1 Cautions When Installing.	7
3-2 Caution when Handling.	7
3-3 When Transporting.	7
4. INSTALLATION	8
4-1 Connecting the Seat Assemblies to the Cabinet.....	8
4-2 Adjusting the Level Adjusters.....	8
5. ADJUSTMENTS	8
5-1 Turning on the Power	8
5-2 Switches for Adjustments	8
5-3 Test Mode	9
5-3-1 Setting the Game Fee and So On (On the Coin Options Screen)	10
5-3-2 Changing the Game Settings (on the Game Options Screen)	11
5-3-3 Switch Test	12
5-3-4 Sound Test (Adjusting the Sound Volume)	13
5-3-5 Lamp Test	13
5-4 Adjusting the Game After Replacing Parts (Initializing the Game)	14
5-5 CONNECTING MULTIPLE GAME LINKS	15
6. HOW TO PLAY	16
7. MAINTENANCE	17
7-1 Replacing Fluorescent Lamps	17
7-2 Replacing the Leading Driver Lamps	17
7-3 Removing the Game Printed Circuit Board (PCB)	18
7-4 Removing the Shield Case	19
7-5 Removing the Power Control Panel	19
7-6 AB Pedal Assy (Replacing the Control)	19
7-7 Gear Shift Assy (removing)	19
7-8-1 Replacing the control	20
7-8-2 Replacing The Steering Wheel	20
8. PARTS	21
9. SCHEMATIC	22

1. SPECIFICATIONS

POWER SUPPLY :-

220/240volts AC

MONITOR:-
auto degauss.

Hantarex 28" Polo Colour Monitor with

DIMENSIONS :-

When Assembled:-	1400(w) x 1770(d) x 1980(h)
Cabinet:-	1400(w) x 920(d) x 1980(h)
Seat Assy:-	470(w) x 940(d) x 1230(h)

WEIGHT :-

When Assembled:-	310kg
Cabinet:-	250kg
Seat Assy:-	30kg (ea)

ACCESSORIES :-

Keys: (Cash Door)	2
(Coin Assy)	2
(Back Door)	2ea
M10x30 Hex Head Bolts	24
M10 Flat Washer	24
M10 Spring Washer	24
Seat/Cabinet Joint Bracket	4
Phono Link Lead	1
IEC mains Lead	1
Operators Manual	1

2. MAJOR COMPONENTS

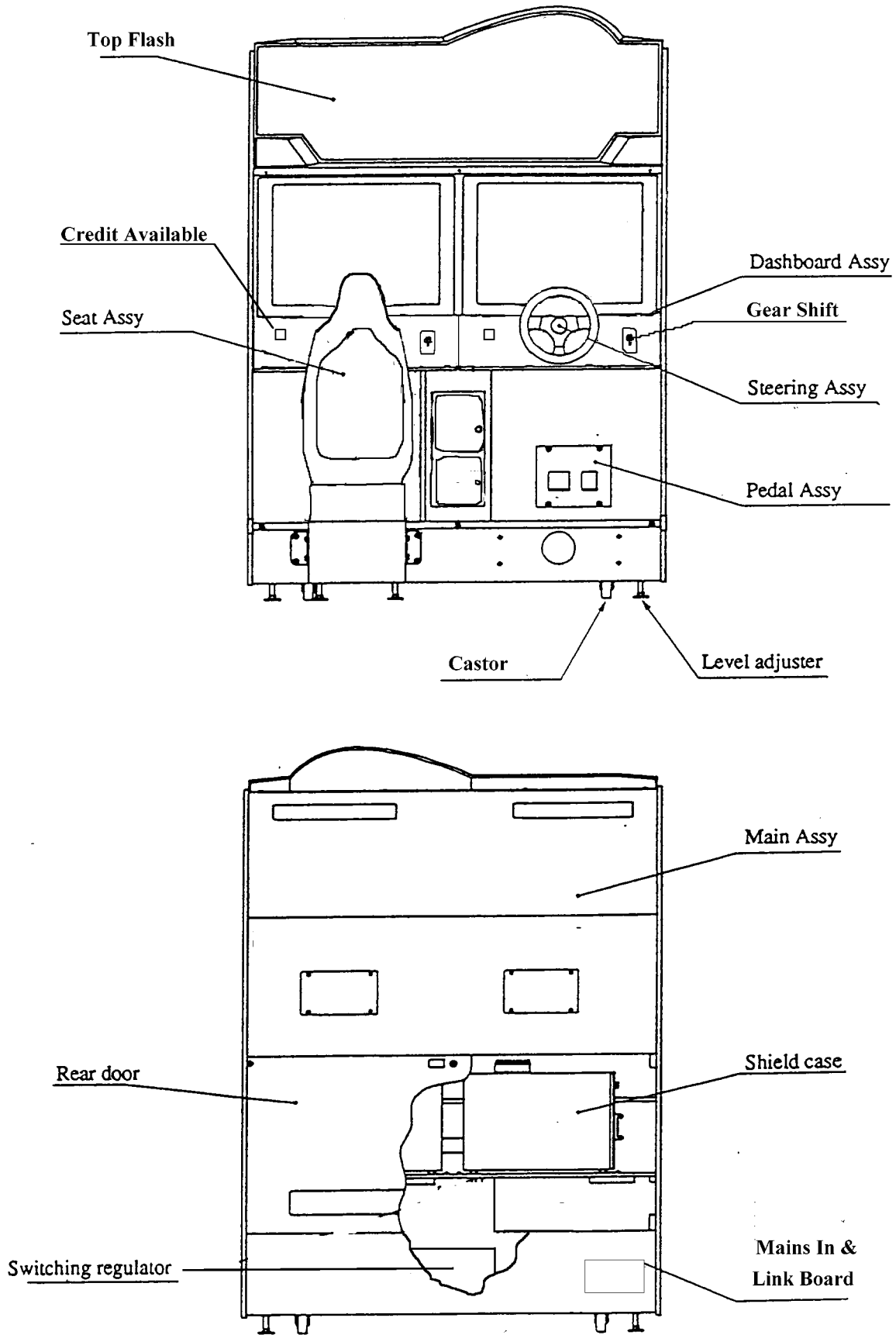

Figure 2

3. PRECAUTIONS

3-1 Cautions When Installing.

This game is designed for indoor use only. The game must not be installed outdoors or under the following conditions:-

- a. In areas directly exposed to sunlight, high humidity, direct water contact, dust, high heat or extreme cold.
- b. In locations that would present an obstacle in the case of an emergency, i.e.. near fire equipment or emergency exits.
- c. On an unstable surface or subject to floor vibration.

3-2 Caution when Handling.

- a. AC power must always be turned OFF, and the game disconnected, before replacing any parts or connecting/disconnecting connectors.
- b. When unplugging the game from an electrical outlet, always grasp the plug, not the mains lead.
- c. The machine must be earthed with a securely connected earthed plug.
- d. Care must be taken at all times to avoid electric shock when inspecting or adjusting the game.
- e. Adjustment is required whenever the game PCB board, ROM, Steering Assy, AB pedal Assy or control are replaced. (See 5-4 "Adjusting the Game After Replacing Parts" on page 10)

3-3 When Transporting.

- a. Do not subject the game to physical shock when transporting or moving it.
- b. Always return the levellers to the UP position before moving the machine.
- c. Take care not to rope any moulded (plastic) parts when transporting.
- d. Always separate the seat assemblies from the cabinet before moving or transporting.

4. INSTALLATION

Remove from the cash box the four joint plates, 24 off M10x30 hex head bolts, 24 off M10 flat washers and 24 off M10 spring washers.

4-1 Connecting the Seat Assemblies to the Cabinet

1. Place the cabinet in the installation position.
2. Connect the connectors from the cabinet to the connectors in the seat assemblies.
3. Fix the seat assemblies to the cabinet using the joint plates, M10 hex head bolts, flat washers and spring washers taking care not to trap any wires between the seat assemblies and cabinet.

4-2 Adjusting the Level Adjusters

Adjust the level adjusters of the cabinet and seat assemblies (four each for the cabinet and each seat assembly) with a wrench (24mm) so that the castors are raised from the floor by about 5mm. Ensure the machine is level and stable then back up the lock nut to lock the adjuster.

5. ADJUSTMENTS

5-1 Turning on the Power

After installing the product, turn on the power. The power switch is located above the mains inlet on the rear of the cabinet.

5-2 Switches for Adjustments

Open the coin door for access to the switches for adjustments.

1. Service Switch
Press this switch to establish credits without incrementing the coin counter.
2. Test Switch
Set this switch to "ON" to enter test mode. You can change the price of play and perform various tests in Test Mode. (See "5-3 Test Mode" on page 5)

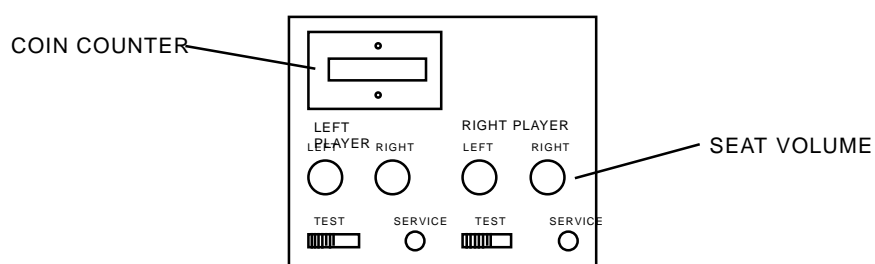

5-3 Test Mode

1. Open the coin door, set the test switch to "ON". The "Menu Screen" appears on the monitor display.
2. Select the item to be tested by turning the steering wheel right or left. The colour of the item you select changes.
3. Step on the accelerator pedal to display the menu of the selected item. To return to the "Menu Screen" step on the brake pedal
4. When the test finishes, set the test switch to "OFF" to return to the Game Screen.

The Test switch must always be "OFF" during normal game mode.

MENU	
COIN OPTIONS	(a) For setting the price of play (see 5-3-1)
GAME OPTIONS	(b) For setting the game options (see 5-3-2)
BOARD TEST	(c) For testing the game PCB
SWITCH TEST	(d) For testing switches (see 5-3-3)
SOUND TEST	(e) For adjusting the sound volume (see 5-3-4)
MONITOR TEST	(f) For monitor adjustments
ADS TEST	(g) For displaying game data collected
PCG TEST	(h) For testing game graphics
LAMP TEST	(i) For testing leading driver lamps
ABOUT	(j) For restoring each setting to standard value
IN=STEP ON THE GAS	

5-3-1 Setting the Game Fee and So On (On the Coin Options Screen)

Select 1 “COIN OPTIONS” on the Menu Screen to set the game fee

Turn the steering wheel to select the item to be changed, then step on the accelerator pedal.

Turn the steering wheel again to change the setting, then step on the accelerator pedal (See table 1.)

Step on the brake pedal to return to the Menu Screen.

Note: *The price of play adjustments are made on the credit dispense board (located inside the coin door) and the coin options should be set as the following table.*

COIN OPTIONS	
GAME COST 2 COINS 1 CREDIT	(a)
COIN 1 MECH VALUE 1 COIN COUNT AS 1 COIN	(b)
COIN 2 MECH VALUE 1 COIN COUNT AS 1 COIN	(c)
BONUS FOR QUANTITY BUY-IN NONE	(d)
FREE PLAY OFF	(e)
EXIT = STEP ON THE BRAKE	

Item	Description		
(a) Game fee	Number of credit pulses necessary for game credit	One to nine	Set to 1
(b) Coin 1 mechanism	Number of credit pulses per coin	One to nine	Set to 1
(c) Coin 2 mechanism	Not Used	One to nine	
(d) Bonus	The extra credit given as a bonus when the specified number of coins are inserted	One credit per one coin Three credits per nine coins	Set to NONE
(e) Free play	Free play started by stepping on the accelerator	OFF/ON	set to OFF

5-3-2 Changing the Game Settings (on the Game Options Screen)

Select 2 "GAME OPTIONS" to change the game options.

Turn the steering wheel to select the item to be changed then step on the accelerator pedal.

Turn the steering wheel again to change the setting, then step on the accelerator pedal (see table below).

Step on the brake pedal to return to the Menu Screen.

Set the rank and number of laps the same for each connected machine. Set the CPU numbers starting in ascending order with

GAME		OPTIONS		
(DEFAULT	IN	GREEN)		
<u>GAME</u>	<u>DIFFICULTY</u>	<u>TIME</u>	<u>EXTEND</u>	
	NOVICE	D	** ** *	(a)
	ADVANCED	D	** ** *	(b)
	EXPERT	D	** ** *	(c)
	T.T.	D	** ** *	(d)
	LINKABLE	D	** ** *	(e)
<u>LAP</u>				
	NOVICE	2		(f)
	ADVANCED	3		(g)
	EXPERT	3		(h)
	T.T.	3		(i)
	LINKABLE	3		(j)
<u>SPEED</u>		KM/H		(k)
<u>SOUND</u>	<u>IN</u>	<u>ATTRACT</u>	ON	(l)
<u>CPU</u>	<u>No</u>		*	(m)
<u>CAR</u>	<u>TYPE</u>		*	(n)
<u>LINK</u>			*	(o)
EXIT = STEP ON THE BRAKE				

Settings of the Game Options Screen

Item	Description	Factory setting
(a) Play time for the novice level	A (shortest) to H (longest)	D
(b) Play time for the advanced level	A (shortest) to H (longest)	D
(c) Play time for the expert level	A (shortest) to H (longest)	D
(d) Play time for the time trial game	A (shortest) to H (longest)	D
(e) Play time for linked game	A (shortest) to H (longest)	D
(f) Laps for the novice level	2 to 5	2
(g) Laps for the advanced level	2 to 5	3
(h) Laps for the expert level	2 to 5	3
(i) Laps for the time trial game	2 to 5	3
(j) Laps for the linked game	2 to 5	3
(k) Unit of speed	KMH (Kilometers per Hour) MPH (Miles per Hour)	Set for Country of Use
(l) Attract sound	ON/OFF	ON
(m) CPU No.	0 to 7	Set in order starting from the left
(n) Car type	1 BLUE 2 YELLOW 3 RED 4 GREEN 5 BLUE 6 YELLOW 7 RED 8 GREEN	1 BLUE - Left Player 2 YELLOW - Right Player <i>When linked to other machines set to player No.</i>
(o) Link	2, 4, 6 or 8	Displays number of linked machines. If there is a problem or only one seat set, (NG) will be displayed.

5-3-3 Switch Test

Select 3 "SWITCH TEST" to display the following screen.

SWITCH TEST		
DIP SW2	1 2 3 4 5 6 7 8	(a) Option switch (SW2 on the CPU)
SW3	1 2 3 4 5 6 7 8	(b) Option switch (SW3 on the CPU)
STEERING	*0000	(c) Steering
GAS	*0000	(d) Accelerator
BRAKE	*0000	(e) Brake
SHIFT	CENTRE SWITCH 1 OFF SWITCH 2 OFF	(f) Shift
SERVICE	OFF	(g) Service switch
COIN 1	OFF	(h) Coin 1 switch
COIN 2	OFF	(i) Coin 2 switch
EXIT = STEP ON THE BRAKE AND ACCELERATOR		

- The status of the option switch SW2 on the game PCB (CPU-PCB) is indicated here.
- The status of the option switch SW3 on the game PCB (CPU-PCB) is indicated here.
The SW2 or SW3 switch is set to ON when the corresponding number is red.
- When you turn the steering wheel to the right, the number increments. When turning it to the left, the number decrements.
- When you step on the accelerator pedal, the number increments.
- When you step on the brake pedal, the number increments. An approximate value of "0000" appears on the item c, d or e respectively when you locate the steering wheel in the middle and when the accelerator and brake pedals are released. (Even if the least digit of the number changes, the game is operating normally). "OK" appears to the right of the number when the accelerator and brake pedals are depressed.
- The position of the shift and the status of two switches are indicated here.
When you move the shift lever to low CENTRE changes to DOWN and switch 1 is set to ON. When you move it to high Centre changes to UP and switch 2 is set to ON.
- "ON" appears when you press the service switch inside the coin door.
- "ON" appears when you operate the credit available button only if credits are established on the dispense board.
- Not used.

To return to the Menu Screen, step on both the brake and gas pedal at the same

5-3-4 Sound Test (Adjusting the Sound Volume)

Select "SOUND TEST" on the menu screen to adjust the sound volume. The following screen appears.

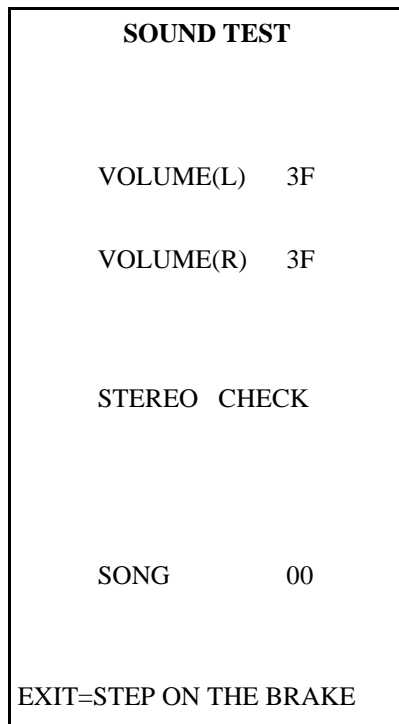

(a) Sound volume for left speakers

(b) Sound volume for right speakers

(c) Stereo checking function

Use the steering wheel to select the item to be changed. Step on the accelerator and the item selected will stop flashing. Use the steering to adjust the level. Step on the accelerator when the desired setting is reached and the item will start flashing. The steering can now select another item.

The sound volume can be adjusted in 64 steps between 00 (minimum) to 3F (maximum). The factory setting is "3F". (i.e. Loudest)

When you select (c) and step on the accelerator pedal, sound is produced the left speaker, then the right speaker. Step on the brake pedal to return to the Menu Screen.

The volume controls on the service bracket enable the seat speakers to be reduced from the main volume.

5-3-5 Lamp Test

The Leading Driver Lamps will turn ON or OFF each time the accelerator pedal is pressed.

5-4 Adjusting the Game After Replacing Parts (Initializing the Game)

Be sure to adjust the game with the following instructions below after replacing any part. Otherwise, the game will not function correctly.

1. Ensure that the accelerator and brake pedals are released and the steering is in the centre.
2. Slide the test switch to “ON” while pressing the service button. The following screen appears on the monitor display.

ADJUST	
STEERING	0000
GAS	0000
BRAKE	0000

3. To zero the settings press the service switch.
4. When each number on the right hand side of the items: STEERING, GAS and BRAKE is about “0000”, the adjustments are complete.
5. Set the test switch to “OFF” to return to the Game Screen.

The test switch must always be “OFF” during normal game mode.

5-5 CONNECTING MULTIPLE GAME LINKS

When installing more than one Ridge Racer 2™ game, the units must be linked using screened audio cable (One lead is supplied with each machine)

1. Ensure that all leg levellers on the game cabinets and seats have all been lowered, and that all castors are clear of the floor. **Make sure that power to all the games is turned OFF.**
2. To link multiple cabinets (2-4 units), locate the LINK PCB, mounted next to the mains-in socket (remove the cover plate to gain access), on each Game Cabinet, and move all slide switches to the "External" (Right) position.

NOTE:- A single cabinet (not linked) must have the slide switch set to the "INTERNAL" (Left) position. If not, the two players will not link.

3. Using the appropriate diagram below, connect the link cables provided from "IN" to "OUT" between each of the game units to be linked.

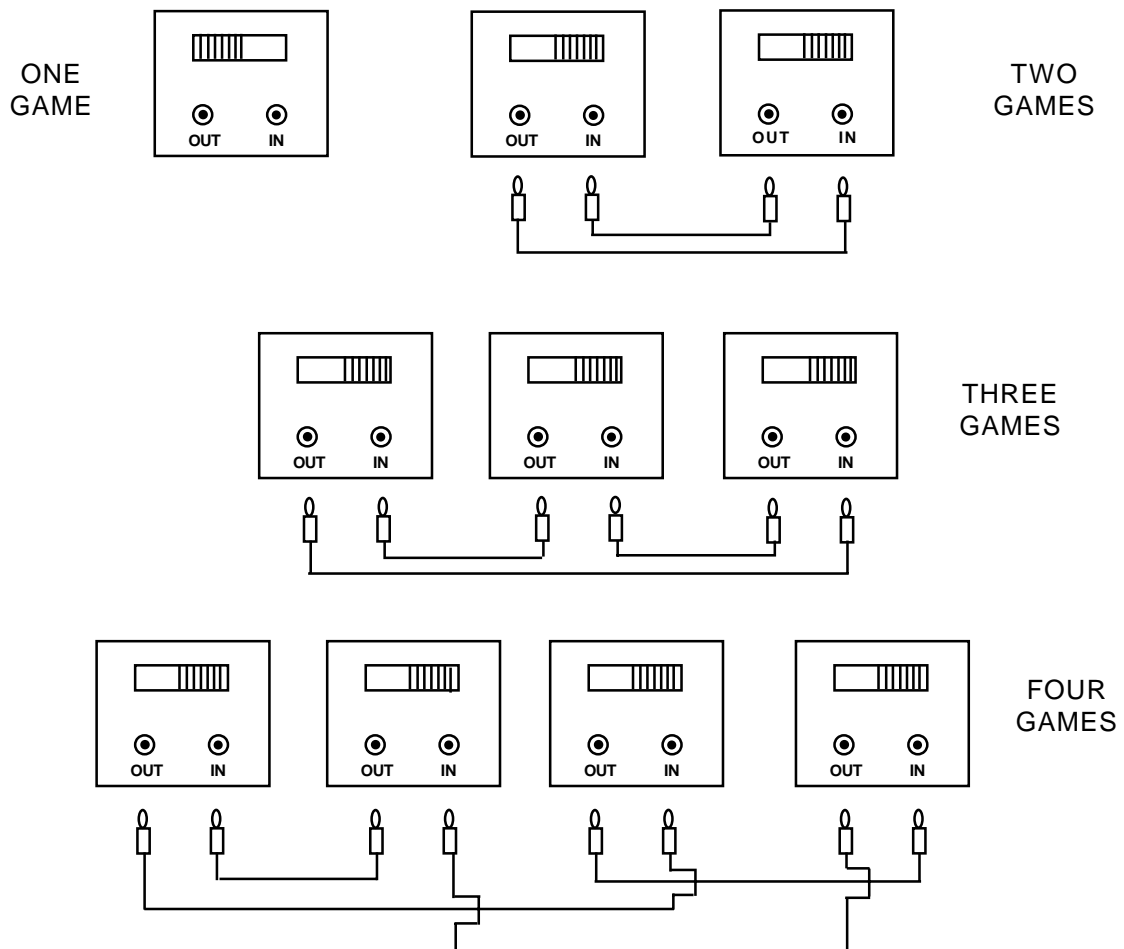

4. Initialize each car (see 5-4 Page 10). **Do this for each car.**
5. Enter the test mode, and using the Option Screen, set the CPU No. and Car Type for each unit. (See 5-3-2, Page 7 "Game Option Screen", for more information).

NOTE:- Each car must have a different CPU and Car Type number for proper operation.

6. HOW TO PLAY

- Players can race by themselves against the computer or head to head on the same track. With four machines linked, up to 8 players can race on the same track.
- Four difficulties are provided. NOVICE, INTERMEDIATE, ADVANCED and T.T.(Time Trials), with up/down gear shift or fully automatic transmission.

(Outline of a Game)

- When a player drives a car the specified number of laps within the given time, they finish the race, the ranking, lap time and total time are displayed and the game is over.
- If the countdown timer reaches 00 before a player finishes the race, the game is over.

(Starting a Game)

- Insert coins, and press the credit available button for each driver. Turn the steering wheel to select MANUAL or AUTOMATIC then press the accelerator. Turn the steering wheel to select NOVICE, INTERMEDIATE, ADVANCED or TT then press the accelerator. A linked game starts when all linked seats have been entered, or when 20 seconds have elapsed since the first credit available button was pressed.

(Difference of Difficulty Levels)

- When a player selects the NOVICE level, he or she drives a car on the MAIN COURSE at a low speed. This is the player's car vs. computer driven cars race game.
- When a player selects the INTERMEDIATE level, he or she drives a car on the MAIN COURSE at a high speed. This is the player's car vs. computer-driven cars race game.
- When a player selects the ADVANCED level, he or she drives a car on the MAIN COURSE and a TECHNICAL BRANCH at a high speed. This is the player's car vs. computer-driven cars race game.
- When a player selects the TT level, he or she drives a car on the MAIN COURSE and the TECHNICAL BRANCH at a higher speed than that of the ADVANCED level. This is the player's car vs. a computer-driven car or other player's time trial race. When a player clocks a good time, they can record their name.
- When drivers are driving against each other in LINK mode, they drive on the intermediate level.

7. MAINTENANCE

7-1 Replacing Fluorescent Lamps

1. Remove the ten M5x16 button head screws, and remove the top flash (see fig. below). taking care to unplug the 2 Leading Driver Lamp plugs.
2. Replace the fluorescent lamp and/or starter.

7-2 Replacing the Leading Driver Lamps

1. Remove the ten M5x16 button head screws, and remove the top flash (see fig. below). taking care to unplug the 2 Leading Driver Lamp plugs.
2. Replace the lamps. (12v 2.2w Wedge Lamps)

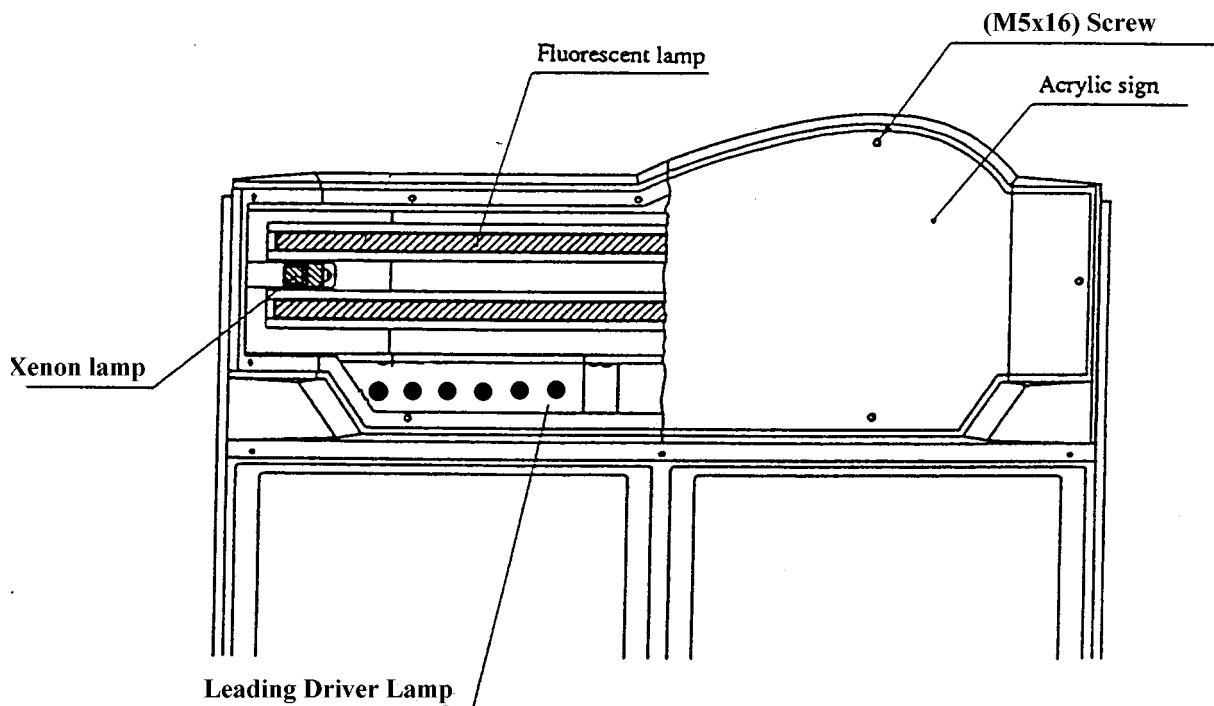

7-3 Removing the Game Printed Circuit Board (PCB)

1. Remove the back door,
2. Remove two assembling bolts (M6 x 30), then pull out the power control panel about 25cm. (Note: if you pull it out too much, it will be detached).
3. Disconnect two connectors on the EMI board, then remove six cup screws (M4 X 10) from the shield case door. (Do not lose internal washers).
4. Take care not to damage the connectors between the EMI board and the main PCB to remove the shield case door, then take out the main pcb.
5. Remove two cup screws (M4 X 10) from the I/O door. (Note: Do not remove other screws).
6. Remove the I/O door, then disconnect four connectors of the I/O PCB.
7. Take out the I/O PCB.

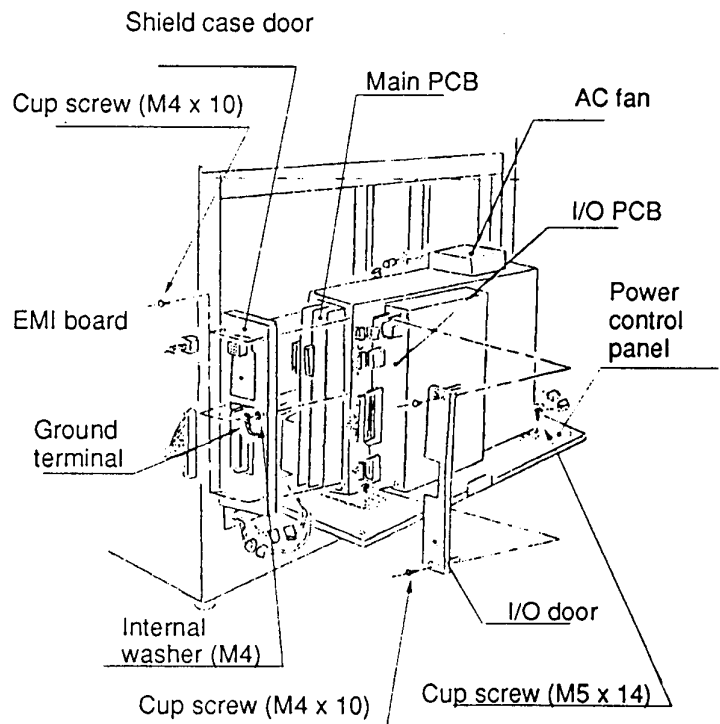
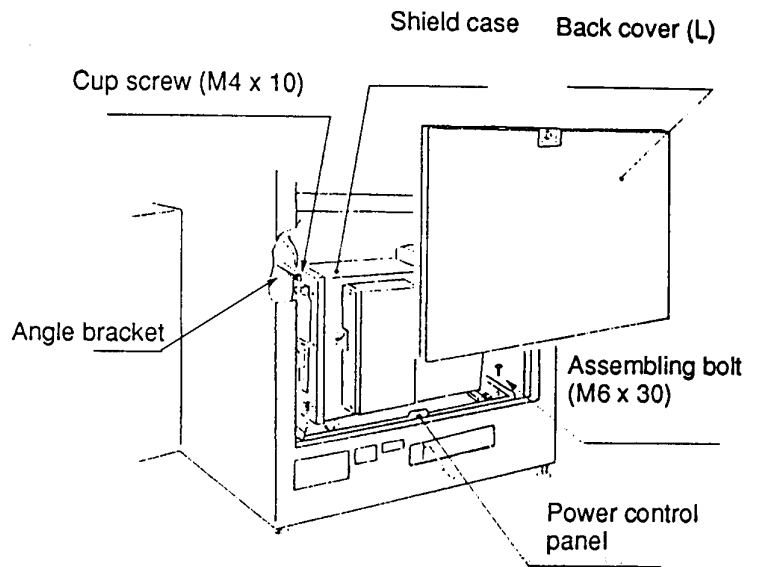

7-4 Removing the Shield Case

1. Perform Steps (1) and (2) described in [Section 7-3](#).
2. Disconnect the connector of the AC Fan.
3. Remove two cup screw (M5 x 14) then take out the shield case.

7-5 Removing the Power Control Panel

- 1 Perform steps 1, 2, 5 and 6 described in [Section 7-3](#).
2. Disconnect two connectors of the EMI board, remove a cup screw (M4 X 10) from the shield case door, then remove the ground terminal. (Note: do not lose the internal washer).
3. Disconnect the connectors connecting the power control panel and the main body assy: one connector on the right side and two connectors on the left side then remove the power control panel.

7-6 AB Pedal Assy (Replacing the Control)

1. Remove four hex head bolts (M6x20) and withdraw the assy forward .
2. Loosen the quadrant gear clamp screw and remove the quadrant gear.
3. Loosen the gear grub screw and remove the gear.
4. Replace the control potentiometer.

Note: When reassembling

- a. Ensure that the potentiometer locating tag is engaged in the mounting plate cutout.
- b. Turn the potentiometer shaft almost fully clockwise before engaging the quadrant gear.

7-7 Gear Shift Assy (removing)

1. Remove 4 off M5x20 button head screws and pull forward the play panel assy and disconnect the four way connector on the gear shift assy.
2. Remove four M4 coach bolts and withdraw the shifter assy.

Re-initialize the game (see 5-4 Page 10 "Adjusting the Game") whenever the game PCB board, ROM, Steering Assy, AB Pedal Assy or Controls are replaced before the game is played.

7-8 Steering Assy

7-8-1 Replacing the control

1. Remove 4 off M5x20 button head screws and pull forward the play panel assy to gain access to the steering assy.
2. Loosen the grub screw on the gear wheel and remove the gear wheel.
3. Replace the control potentiometer.
4. Replace the gear wheel and re-tighten the grub screw securely.

Note: When replacing the control potentiometer ensure that the locating tag of the potentiometer is located in the hole in the mounting bracket and the pot shaft is at its mid travel before tightening the gear grub screw.

7-8-2 Replacing The Steering Wheel

1. Remove the centre cover of the steering wheel.
2. Remove three socket button heads (M6x16)
3. Pull off the steering wheel, then replace it with a new one.

Re-initialize the game ([see 5-4 Page 10 "Adjusting the Game"](#)) whenever the game PCB board, ROM, Steering Assy, AB Pedal Assy or Controls are replaced before the game is played.

8. PARTS

CABINET

Description	Part No.
Monitor 28" Hantarex Polo	84000012
Speaker 4 1/2" 20w (with shield can)	62000006
Speaker - Piezo Horn	62000046
Dual Pedal Assy (with pots)	88800029
Dual Pedal Assy Control Pot (5k)	76000652
Steering Assy (270 deg)	88800001
Steering Control Pot (5k)	76000652
Steering Wheel	88800008
Gear shift Assy	88800009
Credit Available Button Assy	60200215
Power Supply Assy - 5v/30amp	83000004
Schaffner Mains Filter Input Assy	66000016
Fuse 5a 20mm	63500601
Interlock Switch	60000006
Fan	67000015
Front Glass	31000019
100ohm 10w W/W Volume Control	76000164
Slide Switch	60000023
Push button Switch	60000059
4ft Fluorescent Tube	64000014
12v 2.2w Wedge Lamp	64000002
M16 Adjustable Foot	88300079
75mm Castor	59000005

SEAT ASSY

Description	Part No.
Seat - (black)	88300630
Seat Slider Mechanism	88300680
Speaker 4 1/2" 20w	62000006
Speaker Cover Plate (Left)	88300603
Speaker Cover Plate (Right)	88300604
M16 Adjustable Foot	88300079
75mm Castor	59000005

VAC-FORMS/ACRYLIC/DECALS

Description	Part No.
Steering Cover Vac-Form	39000047
Top Flash Vac-Form	45000170
Top Flash Acrylic	30000029
Cabinet Side Decal (Left)	40000037
Cabinet Side Decal (Right)	40000038
Play Panel Instruction Decal	40000043
Seat - Back Decal	40000035
Seat - Ridge Racer Decal	40000042
Seat - Namco Decal	40000036
Top Flash System 22 (Left) Decal	40000039
Top Flash System 22 (Right) Decal	40000040

9. SCHEMATIC

