

A large, black, hand-drawn style letter 'C' with a rough, ink-like texture. It is positioned to the left of the word 'CONTRA'.

CONTRA™

**CONTRA™ is a registered trademark of Konami Inc. © 1987 Konami Inc.
KONAMI® is a trademark of Konami Industry Co., Ltd.**

KONAMI'S CABINET AC FLOW CHART

1. Green/Yellow
2. Black
3. Red
4. Blue
5. Brown
6. Yellow/Red
7. Orange/White
8. Red/White
9. Black/White
10. None
11. None
12. White
13. Orange
14. Green
15. Violet

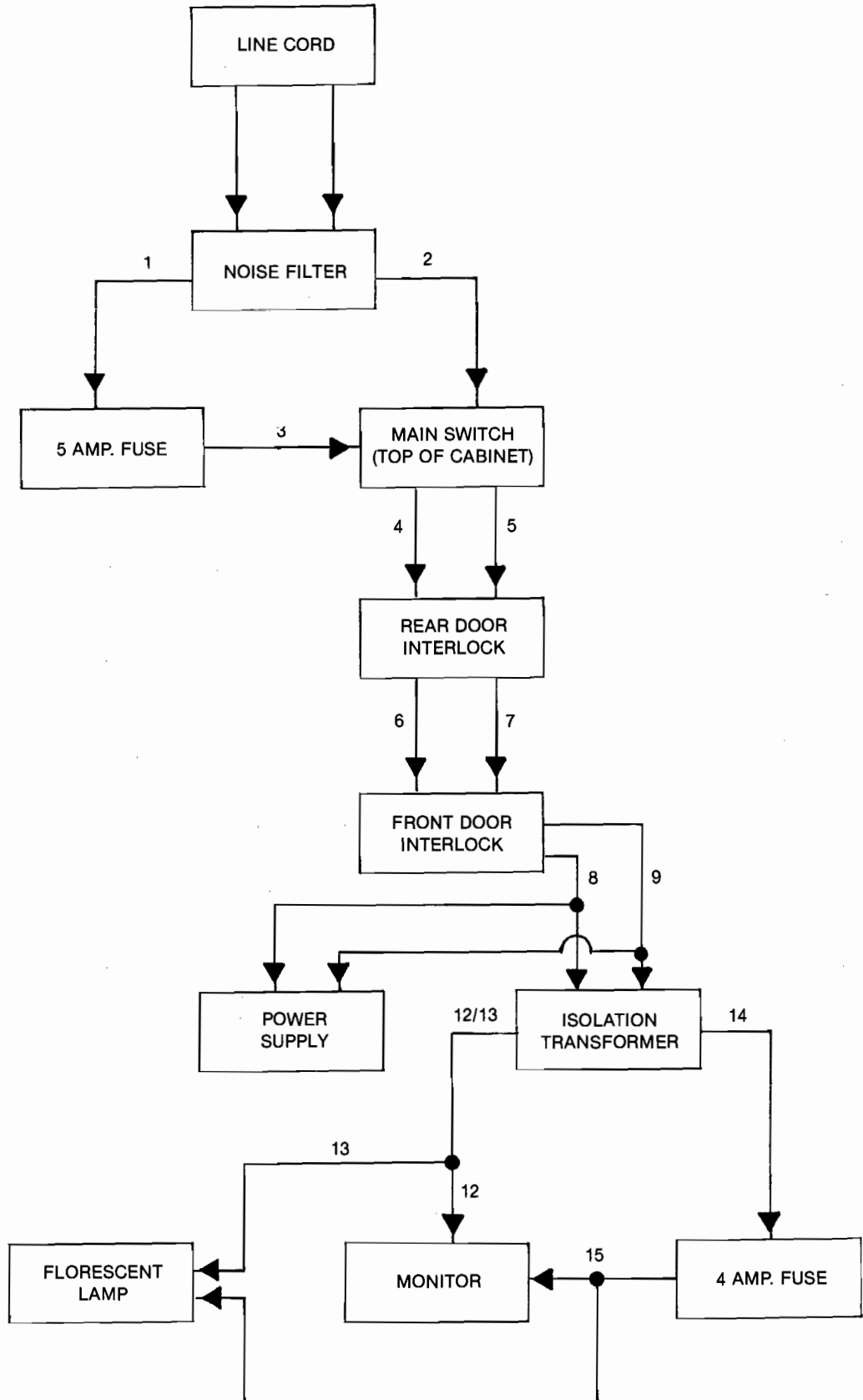

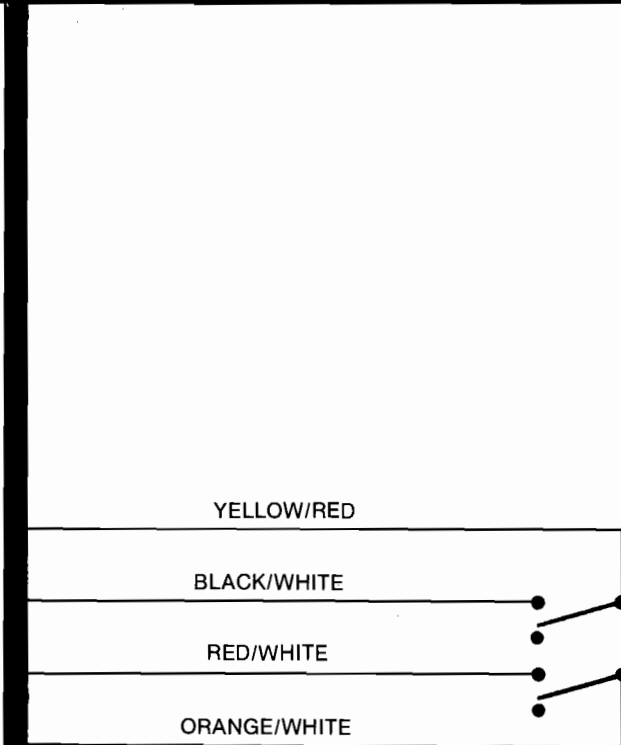
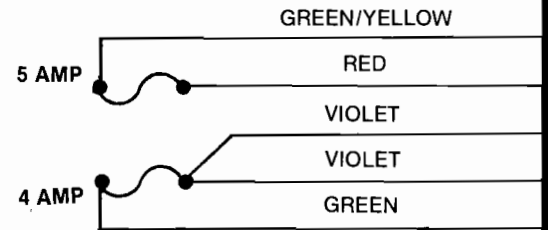
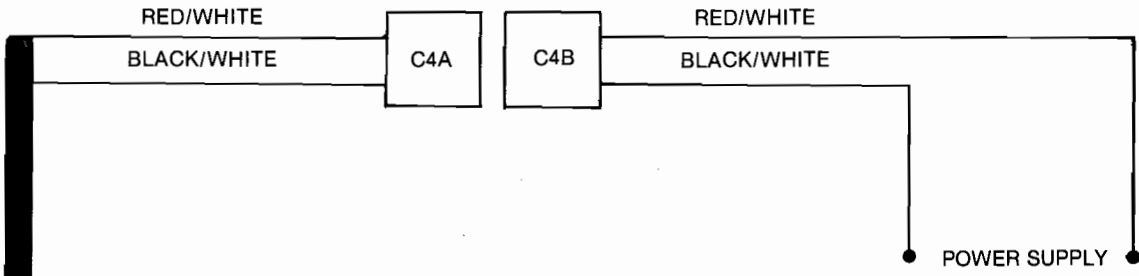

FRONT DOOR INTERLOCK

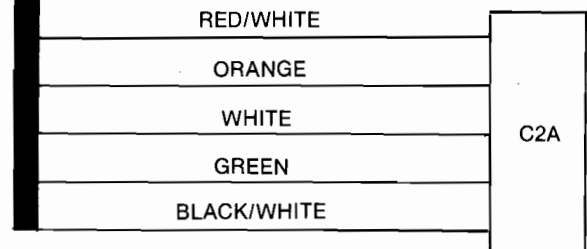

KONAMI'S CABINET AC CABLE

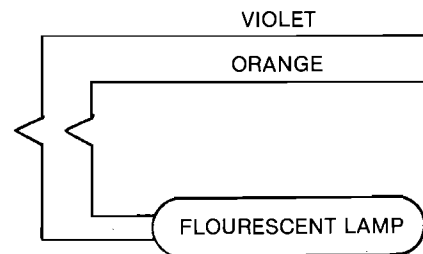
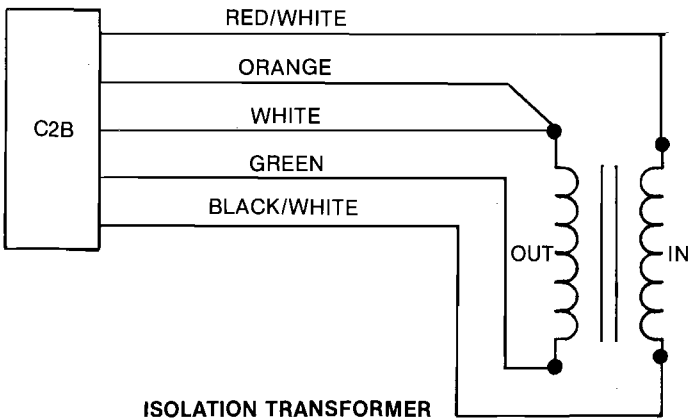
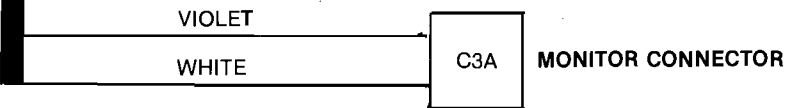
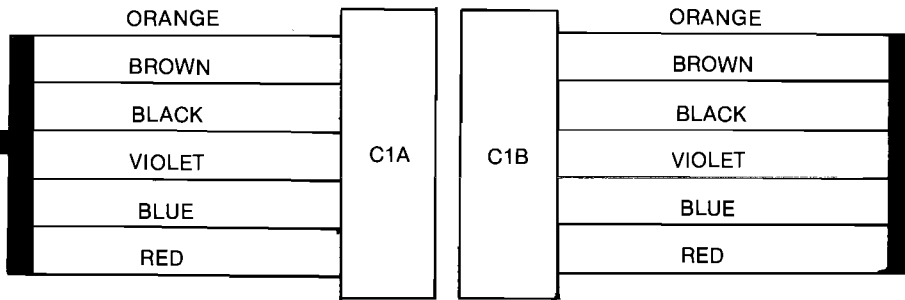
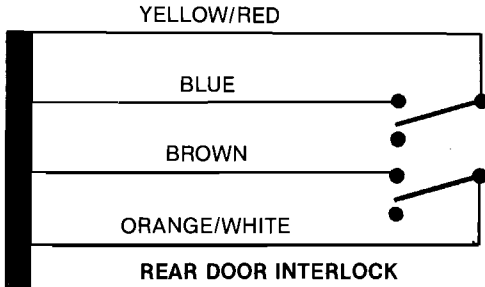
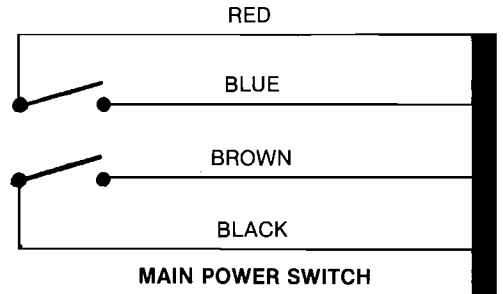
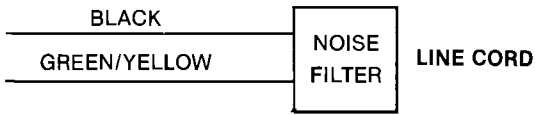

CONTRA

WIRING DIAGRAM

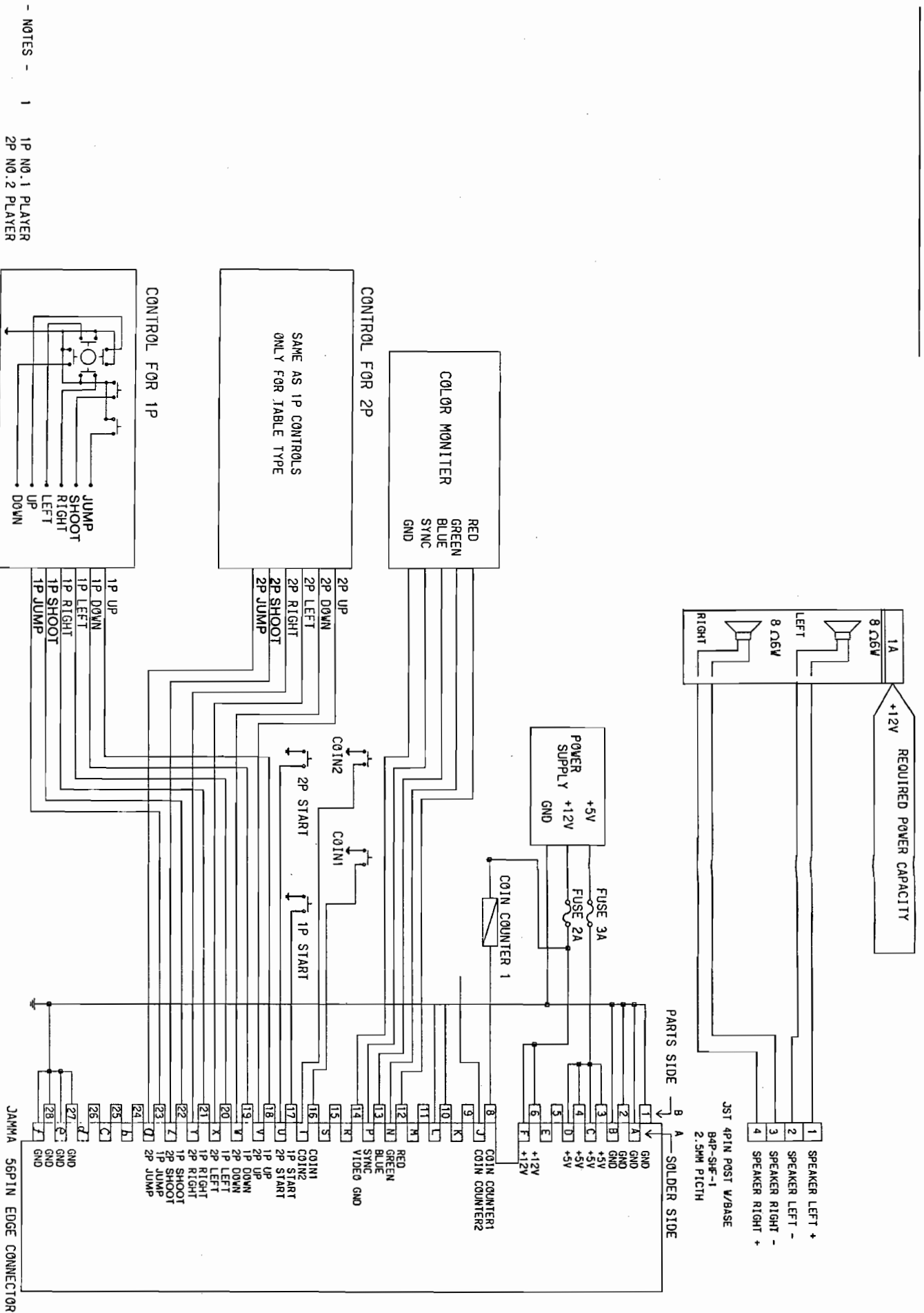

- NOTES -
- 1P NO. 1 PLAYER
 - 2P NO. 2 PLAYER
- SURGE KILLER DIODES FOR COIN COUNTER INSTALLED ON THE P.C.B

CONTRA: WIRING HARNESS

WIRE COLOR KEY:		← Solder Side		Parts Side →	
BLACK	GND	A	1	GND	BLACK
BLACK	GND	B	2	GND	BLACK
RED	+ 5V DC	C	3	+ 5V DC	RED
RED	+ 5V DC	D	4	+ 5V DC	RED
	NOT USED	E	5	NOT USED	
ORANGE	+ 12V DC	F	6	+ 12V DC	ORANGE
	*KEY	H	7	*KEY	
BROWN/YELLOW	COIN COUNTER 2	J	8	COIN COUNTER 1	GREEN/GRAY
	(EMPTY)	K	9	(EMPTY)	
	(EMPTY)	L	10	(EMPTY)	
	(EMPTY)	M	11	(EMPTY)	
WHITE/GREEN	VIDEO GREEN	N	12	VIDEO RED	RED/WHITE
WHITE	VIDEO SYNC	P	13	VIDEO BLUE	BLUE/WHITE
RED/YELLOW	SERVICE SW	R	14	VIDEO GROUND	BLACK
	(EMPTY)	S	15	(EMPTY)	
VIOLET/WHITE	COIN 2	T	16	COIN 1	BLUE/BROWN
RED/GREEN	2P START	U	17	1P START	PINK/YELLOW
BLUE/YELLOW	2P UP	V	18	1P UP	ORANGE/WHITE
VIOLET/YELLOW	2P DOWN	W	19	1P DOWN	BLACK/WHITE
ORANGE/GREEN	2P LEFT	X	20	1P LEFT	RED/GRAY
ORANGE/YELLOW	2P RIGHT	Y	21	1P RIGHT	GRAY/WHITE
BLACK/YELLOW	2P SHOOT	Z	22	1P SHOOT	PINK/WHITE
ORANGE/GRAY	2P JUMP	a	23	1P JUMP	GREEN/BROWN
	NOT USED	b	24	NOT USED	
	NOT USED	c	25	NOT USED	
	NOT USED	d	26	NOT USED	
BLACK	GND	e	27	GND	BLACK
BLACK	GND	f	28	GND	BLACK

(BASE COLOR/LINE COLOR)

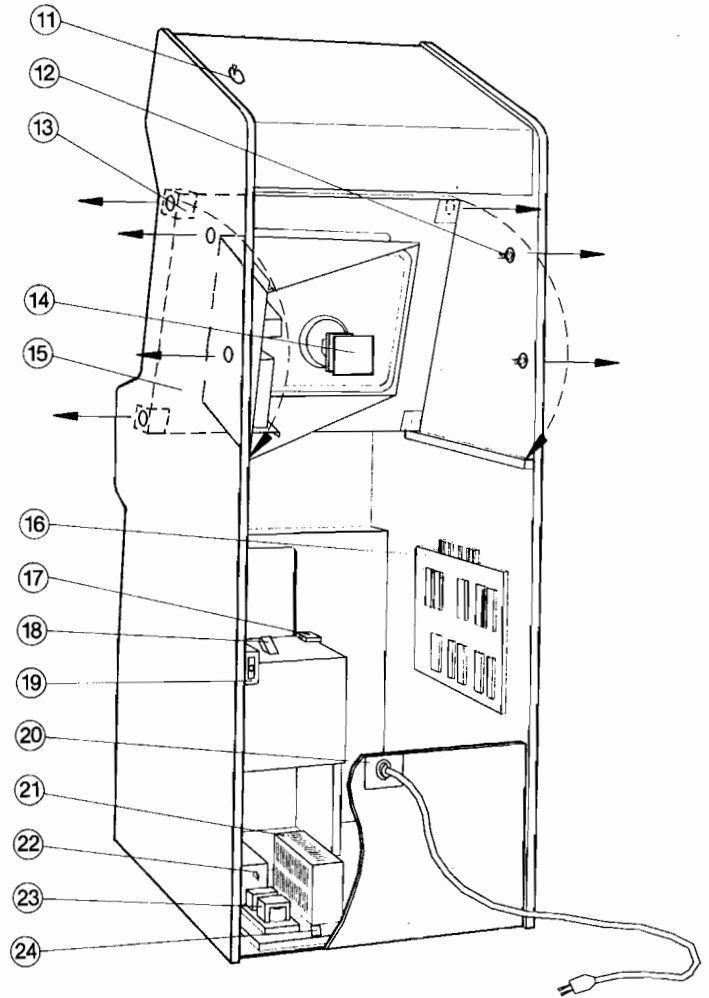
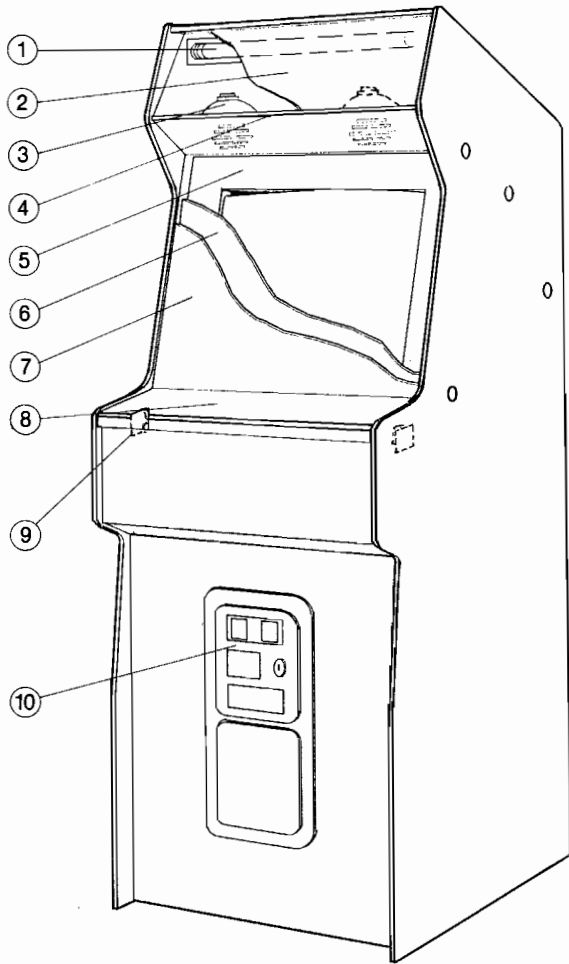

No.	Konami Part No.	Description
1	KEV-101	Marquee Florescent Light
2*	KEV-102	Marquee Plexi
3	KEV-103	8 ohm Speaker x 2
4	KEV-104	Marquee Bracket
5	KEV-105	Foam Monitor Bezal
6	KEV-106	Tinted Plexi
7	KEV-107	Tempered Glass
8*	KEV-108	Wood Control Panel
9	KEV-109	Control Panel Latch (2 piece)
10	KEV-110	Over & Under Coin Door
11	KEV-111	D.P.D.T. On-Off Switch
12	KEV-112	Monitor Bolts x 8

No.	Konami Part No.	Description
13	KEV-113	2-Position Monitor Bracket
14	KEV-114	R.G.B. Monitor
15	KEV-115	Wooden Monitor Housing
16*	KEV-116	Game P.C.B.
17	KEV-117	D.P.D.T. 2-way Interlock Switch
18	KEV-118	12 Volt Coin Meter
19	KEV-119	D.P.D.T. 2-way Interlock Switch
20	KEV-120	Line Cord w/Mounting Bracket
21	KEV-121	4 Output Voltage Power Supply
22	KEV-122	AC Voltage Fuse Holder x 2
23	KEV-123	Isolation Transformer x 2
24	KEV-124	In-Line Noise Filter

NOT SHOWN

- KEV-125 Marquee Light Shield (Cardboard)
- KEV-126 DC Wiring Harness
- KEV-127 AC Wiring Harness

*PLEASE INDICATE NAME OF GAME WHEN ORDERING

COMPLETE COIN DOOR ASSEMBLY EXPLODED VIEW

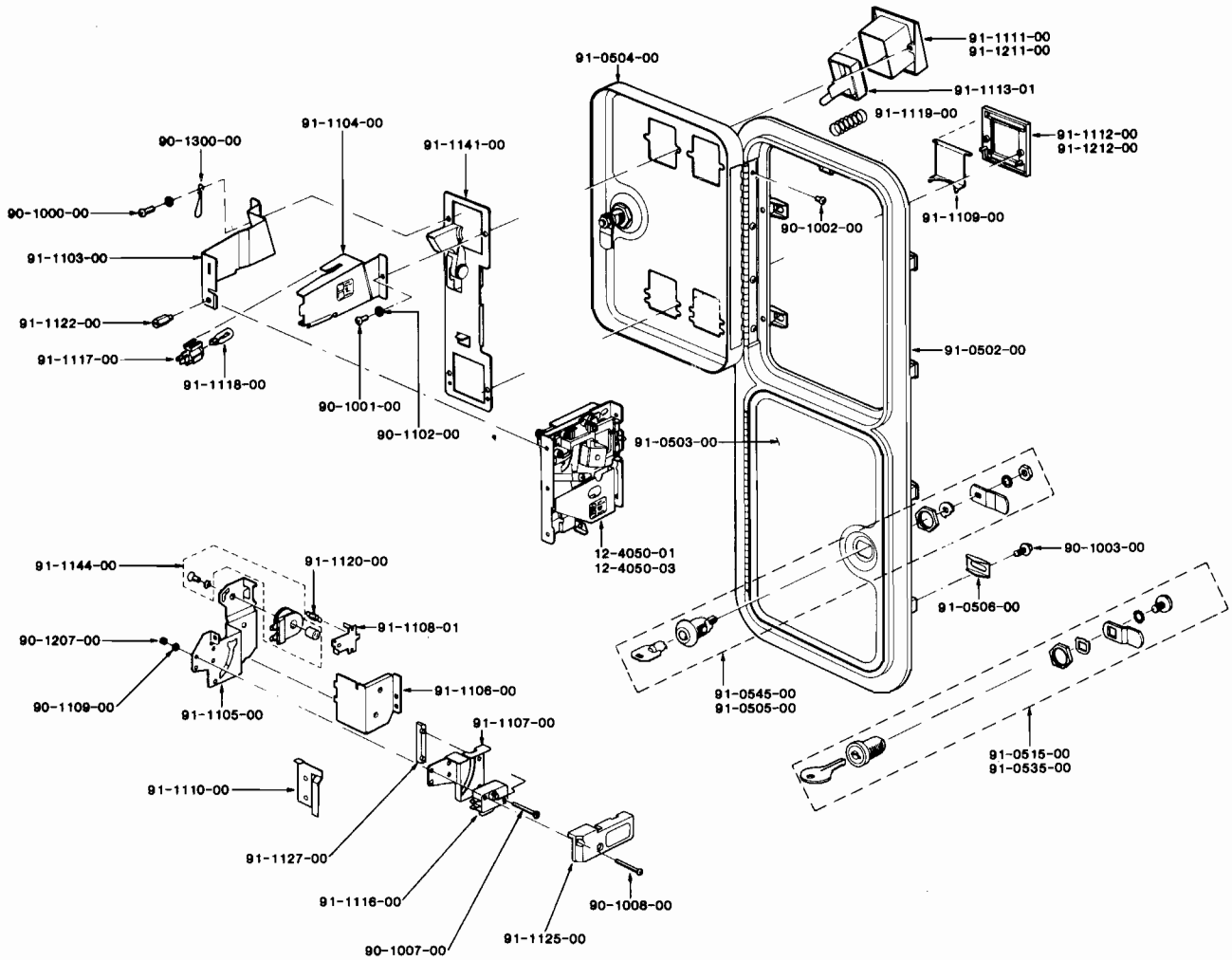

PARTS LIST

12-4050-01 S-10 Acceptor Body US 25°	90-1102-00 Washer for Bezel Screw	91-1103-00 Coin Inlet Lamp Side	91-1119-00 Button Spring
12-4050-03 S-10 Acceptor Body Canadian 25°	90-1207-00 Nut for Microswitch Mounting Screw	91-1104-00 Coin Inlet Cover Side	91-1120-00 Lockout Spring
20-4177-00 Plastic Cash Box	90-1300-00 Keyhook	91-1105-00 Reject Cup Side Plate	91-1122-00 Retaining Screw for Acceptor Body
20-4179-00 Steel Enclosure	91-0502-00 Zinc Die Cast Frame	91-1106-00 Reject Cup Base Plate	91-1125-00 Clear Plastic Cover for Microswitch
22-1400-00 Locking Bar	91-0503-00 Lower Door	91-1107-00 Microswitch Bracket	91-1127-00 Plastic Switch Adjuster
24-1150-00 Wire Harness	91-0504-00 Upper Door	91-1108-01 Lockout Flap US 25°	91-1141-00 Base Plate With Pivot and Stud
90-1000-00 Keyhook Bezel Screw	91-0505-00 Round Lock and Cam Assembly	91-1109-00 Reject Flap	91-1144-00 6 Volt DC Lockout Coil
90-1001-00 Bezel Screw	91-0506-00 Clamp	91-1110-00 Metal Switch Adjuster	91-1120-00 Lockout Spring
90-1002-00 Hinge Screw	91-0515-00 Flat Lock and Cam Assembly	91-1111-00 Black Button Bezel	91-1122-00 Retaining Screw for Acceptor Body
90-1003-00 Clamp Screw	91-0535-00 Flat Lock and Cam Assembly	91-1112-00 Black Reject Bezel	91-1125-00 Clear Plastic Cover for Microswitch
90-1007-00 Flat Head Microswitch Mounting Screw	91-0545-00 Round Lock and Cam Assembly	91-1113-01 Entry/Reject Button US 25°	91-1127-00 Plastic Switch Adjuster
90-1008-00 Panhead Microswitch Mounting Screw		91-1116-00 Microswitch (Black End Arm)	91-1141-00 Base Plate With Pivot and Stud
		91-1117-00 Lampholder	91-1144-00 6 Volt DC Lockout Coil
		91-1118-00 6 Volt Wedge Base Lamp	91-1120-00 Lockout Spring

QUICK CHANGE MONITOR

AS ALWAYS, WHEN INVOLVED IN SERVICING OF A VIDEO MONITOR BE EXTREMELY CAREFUL OF THE HIGH VOLTAGE.

The Konami Cabinet has been uniquely designed to be utilized for a horizontal or vertical monitor game. The Konami Cabinet is built with a vertical style monitor which is mounted on a 22½" by 22½" square mounting board. The monitor mounting board has a 13 gauge steel two-way bracket in each corner. Since the monitor board is square and the brackets are mirror-imaged, the monitor can be quickly and easily converted from vertical to horizontal or vice-versa.

1. Make sure the power line cord is unplugged.
2. Remove back door and control panel.
3. Remove tempered glass, tinted plexi, and foam bezel.
4. Disconnect all wires leading to the monitor.
5. Disconnect all wires leading to the top of the cabinet.
6. Remove bolts 'B', 'C', and 'D' from each side of the cabinet.
7. Lower the top part of the monitor down, leaving the pivoting bolt 'A' in place, until the monitor rests on the shelf (as shown in figure to the right).
8. Remove bolts 'A' and the monitor is free to slide out of the cabinet.
9. Turn monitor to desired position.

NOTE: When mounting the monitor vertically; monitor chassis should be toward the bottom of the cabinet.
When mounting the monitor horizontally; monitor chassis should be to your left when looking in the back of the cabinet.

10. Slide monitor back into the cabinet.
11. Secure bottom of monitor with bolts 'A'.
12. Depending on desired angle secure top of monitor bolts $B \approx 70^\circ$
 $C \approx 40^\circ$
 $D \approx 15^\circ$
13. Reconnect all wires.

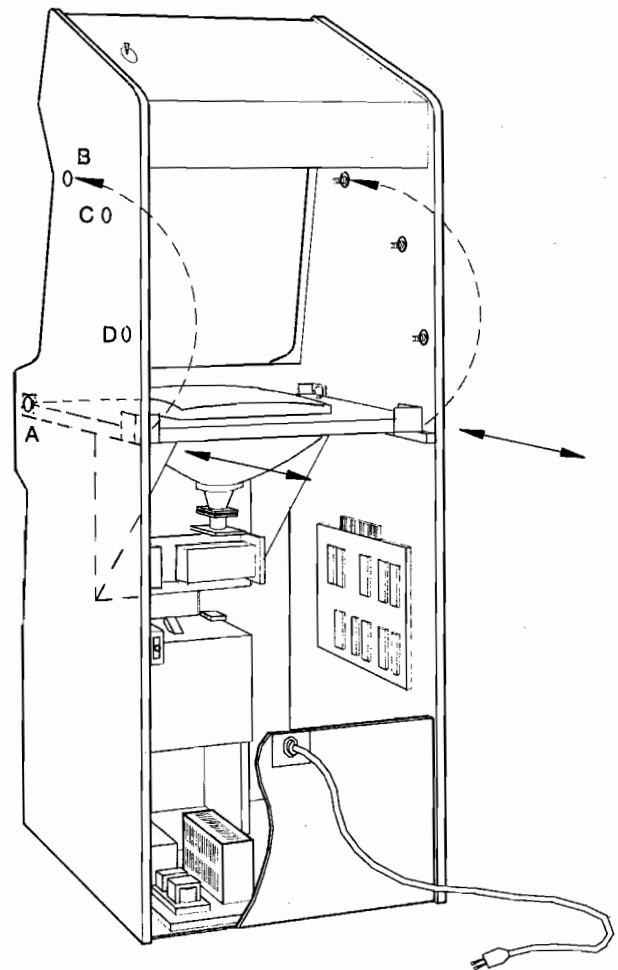

CONTRA

DIP SWITCH SETTINGS

DIP SWITCH NO. 1 SETTINGS

1. COIN.1

SW	1	2	3	4	COIN	PLAY
●	OFF	OFF	OFF	OFF	1	1
	ON	OFF			1	2
	OFF	ON			1	3
	ON	ON			1	4
	OFF	OFF	ON	OFF	1	5
	ON	OFF			1	6
	OFF	ON			1	7
	ON	ON			2	1
	OFF	OFF	OFF	ON	2	3
	ON	OFF			2	5
	OFF	ON			3	1
	ON	ON			3	2
	OFF	OFF	ON	ON	3	4
	ON	OFF			4	1
	OFF	ON			4	3
	ON	ON			FREEPLAY	

2. COIN.2

SW	5	6	7	8	COIN	PLAY
●	OFF	OFF	OFF	OFF	1	1
	ON	OFF			1	2
	OFF	ON			1	3
	ON	ON			1	4
	OFF	OFF	ON	OFF	1	5
	ON	OFF			1	6
	OFF	ON			1	7
	ON	ON			2	1
	OFF	OFF	OFF	ON	2	3
	ON	OFF			2	5
	OFF	ON			3	1
	ON	ON			3	2
	OFF	OFF	ON	ON	3	4
	ON	OFF			4	1
	OFF	ON			4	3
	ON	ON			VOID	

DIP SWITCH NO. 2 SETTINGS

SW3: NOT USED

1. THE NUMBER OF THE PLAYER'S LIFE

SW	1	2	NUMBER
●	OFF	OFF	2
	ON	OFF	3
	OFF	ON	5
	ON	ON	7

3. BONUS LIFE

SW	4	5	BONUS LIFE
●	OFF	OFF	at 30,000 pts, then every 70,000 pts
	ON	OFF	at 40,000 pts, then every 80,000 pts
	OFF	ON	at 40,000 pts only
	ON	ON	at 50,000 pts only

4. DIFFICULTY OF THE GAME

SW	6	7	DIFFICULTY
●	OFF	OFF	EASY
	ON	OFF	NORMAL
	OFF	ON	DIFFICULT
	ON	ON	VERY DIFFICULT

5. SOUND IN ATTRACTIVE MODE

SW	8	SOUND
●	OFF	OFF
	ON	ON

DIP SWITCH NO. 3 SETTINGS

SW2: NOT USED

1. VIDEO SCREEN FLIP

SW	1	
●	OFF	NORMAL
	ON	UPSIDE DOWN

3. CHANGE OF MODE

SW	3	MODE
●	OFF	GAME MODE
	ON	TEST MODE

4. SOUND MODE

SW	4	SOUND MODE
●	OFF	STEREO
	ON	MONAURAL

● SHOWS NORMAL SETTING