

# BOB & CHARLES

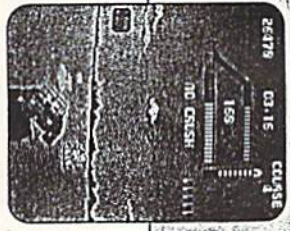

LICENSED BY

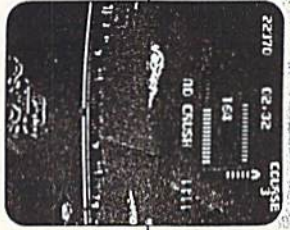
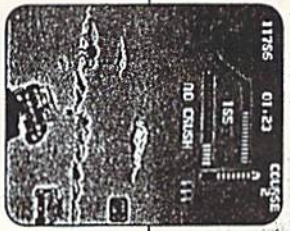
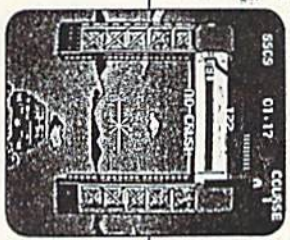

# COMPANIES

Telex: 441879  
FAX [305] 594-0617

4380 N.W. 72nd Avenue • Miami, Florida 33166 • [305] 593-5111



\*\*\*\*\* WARNING \*\*\*\*\*

THIS EQUIPMENT CAN GENERATE AND RADIATE RADIO FREQUENCY ENERGY, WHICH MAY CAUSE INTERFERENCE TO RADIO COMMUNICATIONS IF NOT INSTALLED AND USED IN ACCORDANCE WITH THE INSTRUCTIONS. IT HAS BEEN TESTED AND FOUND TO COMPLY WITH THE LIMITS FOR CLASS "A" COMPUTING DEVICE, PURSUANT TO SUBPART "J" OF PART 15 OF FCC RULES. THESE REGULATIONS ARE DESIGNED TO PROVIDE REASONABLE PROTECTION AGAINST SUCH INTERFERENCE WHEN OPERATED IN A COMMERCIAL ENVIRONMENT. OPERATION OF THIS EQUIPMENT IN A RESIDENTIAL AREA IS LIKELY TO CAUSE INTERFERENCE, IN WHICH CASE THE USER AT HIS OWN EXPENSE, WILL BE REQUIRED TO TAKE WHATEVER MEASURES MAY BE REQUIRED TO CORRECT THE INTERFERENCE.

\*\*\*\*\*



PACKING LIST

"BUGGY CHALLENGE" CONVERSION KIT

- 1 - Main PCB Assembly
- 1 - Relay Board
- 1 - Front Glass
- 2 - Side Decals
- 1 - Photo Sensor Board
- 1 - 'K' Harness
- 1 - F.C.C. Cage
- 1 - Relay Harness
- 1 - Bag of hardware, includes:
  - 1 - Photo Sensor Bracket
  - 1 - Photo Sensor Base Bracket
  - 2 - Pan Head m3 x 6 screws
  - 6 - Pan Head m3 x 10 screws
  - 4 - m3 Lock Washers
  - 2 - m3 Flat Washers
  - 4 - m3 x 50 Pan Head Screws
  - 8 - Res Lock (OL-E3)
  - 8 - 3/4" Spacers
  - 8 - 5/8 x #6 Wood Screws

TURBO (UPRIGHT) TO BUGGY CHALLENGE

MAKE SURE TURBO IS IN OPERATING CONDITION. IT IS NOT NECESSARY FOR THE LOGIC BOARD TO BE OPERATIVE, BUT THE ACCELERATOR, STEERING, AMPLIFIER, MONITOR, SHIFTER AND HARNESS MUST BE OPERATIVE.

DISCONNECTION

DISCONNECT POWER AND REMOVE CONTROL PANEL, BY FIRST REMOVING TWO HEX SOCKET BOLTS FROM THE FRONT OF THE PANEL AND THEN RELEASING THE SUPER CLAMPS THROUGH THE REAR DOOR.

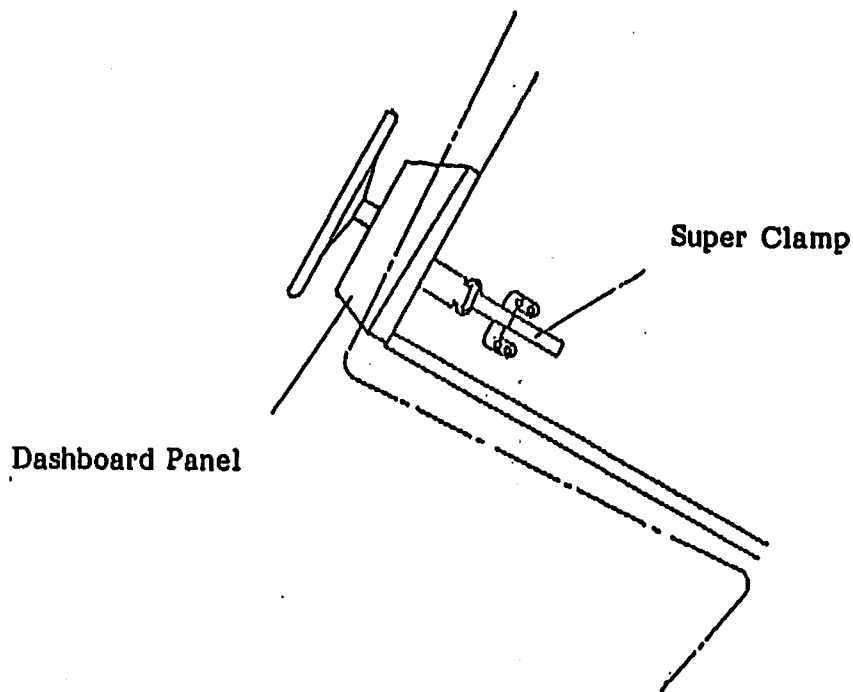

MODIFICATION OF STEERING ASSEMBLY

REMOVE THE TWO SCREWS AND COVER FROM THE BOTTOM OF THE STEERING ASSEMBLY. REFERING TO THE PICTURE, ASSEMBLE PHOTO SENSOR BASE TO BRACKET USING 3M x 10 PAN HEAD SCREWS. DO NOT TIGHTEN THESE BOLTS AT THIS TIME.

MOUNT NEW PHOTO SENSOR BOARD TO BRACKET USING TWO 3M x 6 PAN HEAD SCREWS.

LOOSEN THE TWO FLANGE NUTS ON THE STEERING ASSEMBLY AND SLIDE THE NEW PHOTO SENSOR ASSEMBLY INTO PLACE. TIGHTEN THE FLANGE NUTS.

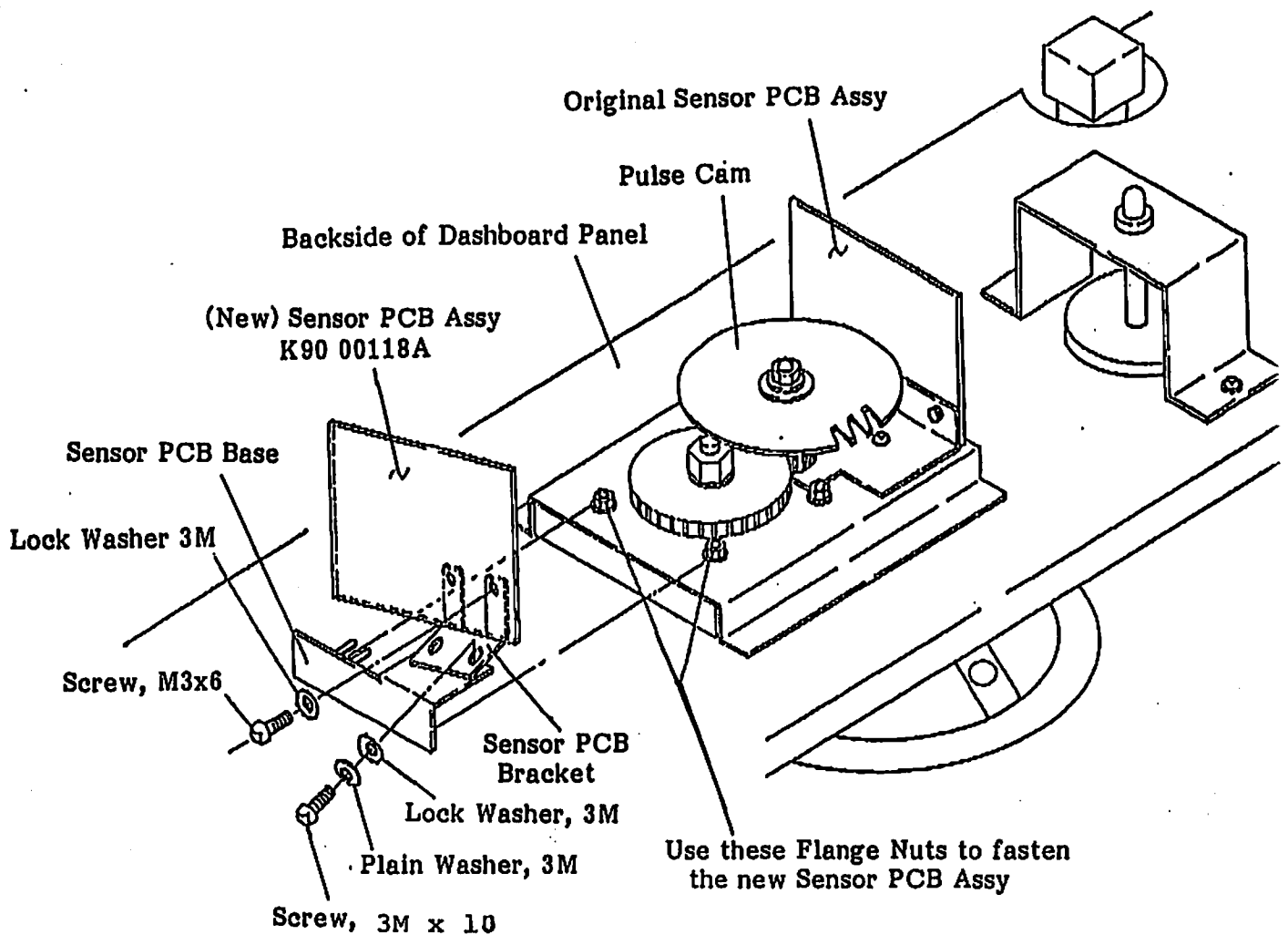
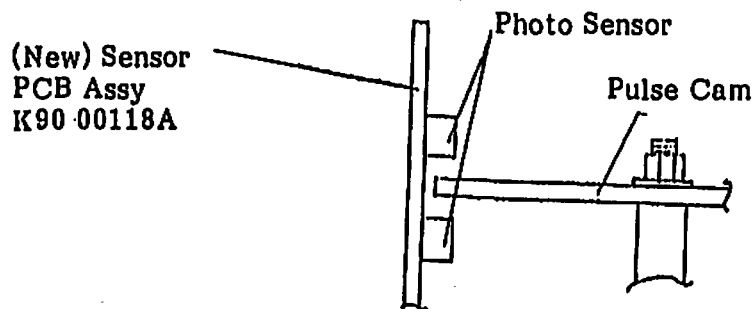

PHOTO SENSOR BOARD ADJUSTMENT

POSITION THE PHOTOSENSOR BOARD SO THAT THE PULSE CAM IS CENTERED BETWEEN THE SENSORS AND TIGHTEN THE SCREWS.

Note: IF THE PULSE CAM IS POSITIONED TOO DEEP IN THE PHOTO DETECTORS THE PULSES FROM THE BOARD WILL BE VERY SHORT, AND THE GAME WILL NOT STEER PROPERLY.



THE ORIGINAL PHOTE SENSOR BOARD IS NO LONGER NEEDED AND MAY BE REMOVED. DO NOT REMOVE THE BRACKET.

- \* Connect the Z-Connector of the K-Harness Assy to the new Sensor PCB Assy.
- \* Disconnect the B-Connector from the original Sensor PCB Assy and connect this B-Connector with the corresponding B-Connector of the above-mentioned K-Harness Assy.

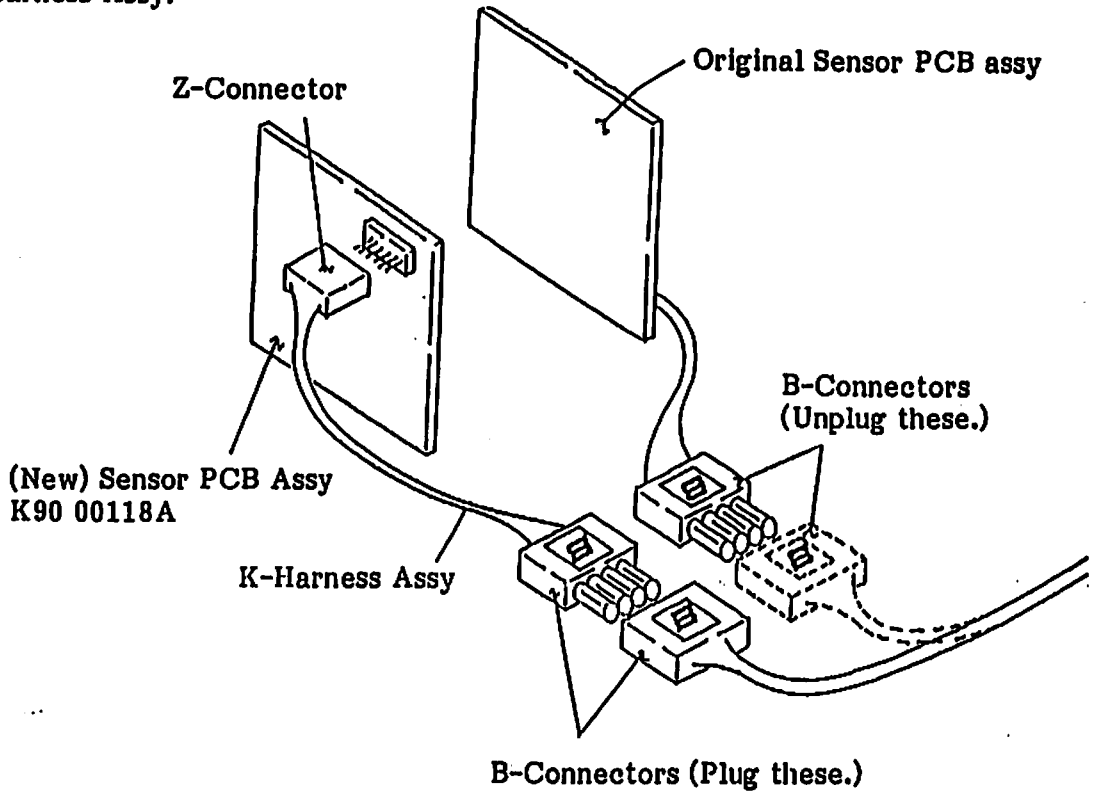

- \* If the B-Connectors are not used in the original game,
  - (1) cut the 4 wires (of the original Main Harness Assy) from the original Photo Sensor PCB,
  - (2) cut off the (male) B-Connector of the K-Harness Assy,
  - (3) connect the above-mentioned 4 wires (of the original Main Harness Assy) to the K-Harness Assy, as shown below.

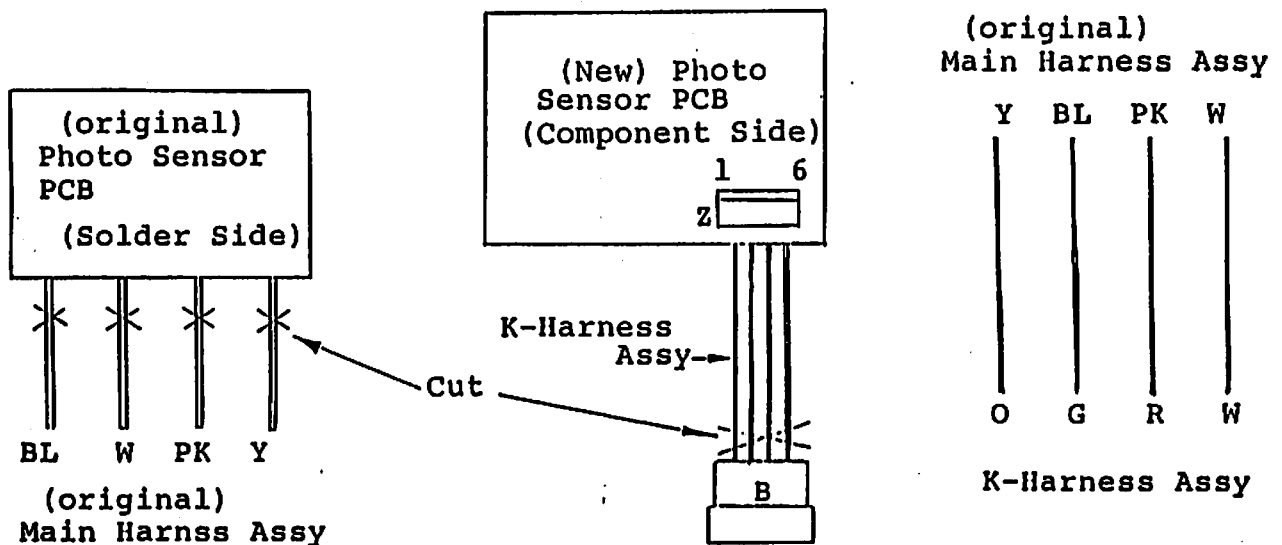



FRONT GLASS INSTALLATION

THROUGH THE REAR DOOR, REMOVE THE BULBS THAT ILLUMINATE "YOUR SCORE" AND "BEST 5" ON TURBO FRONT GLASS.

REMOVE THE ORIGINAL FRONT GLASS. (THIS WOULD BE A GOOD TIME TO CLEAN THE MONITOR.)

REMOVE PROTECTIVE PAPER FROM NEW FRONT GLASS AND INSTALL IN GAME. AS A SUGGESTION, IT MAY BE A GOOD IDEA TO INSTALL 3/8" WIDE WEATHER STRIPPING AT THE BOTTOM EDGE OF THE GLASS TO PREVENT COINS FROM FALLING DOWN INSIDE THE MACHINE WHILE IT IS ON LOCATION.

CHECK WIRES ON THE CONTROL PANEL MAKING SURE THERE IS NO CHANCE THAT THEY WILL GET NEAR THE PULSE CAM.

INSTALL CONTROL PANEL CAREFULLY, AS THERE IS LITTLE CLEARANCE AND NO PROTECTION FOR THE NEW PHOTO SENSOR BOARD. USE TWO BOLTS AND TWO LATCHES. (REFER TO DISCONNECTION)

3. Attaching of Relay PCB Assy and Relay Harness Assy

\* Disconnect the Connectors from the original Main PCB Assy, and remove the Main PCB Assy together with the Guide Assy from the Back Door side.

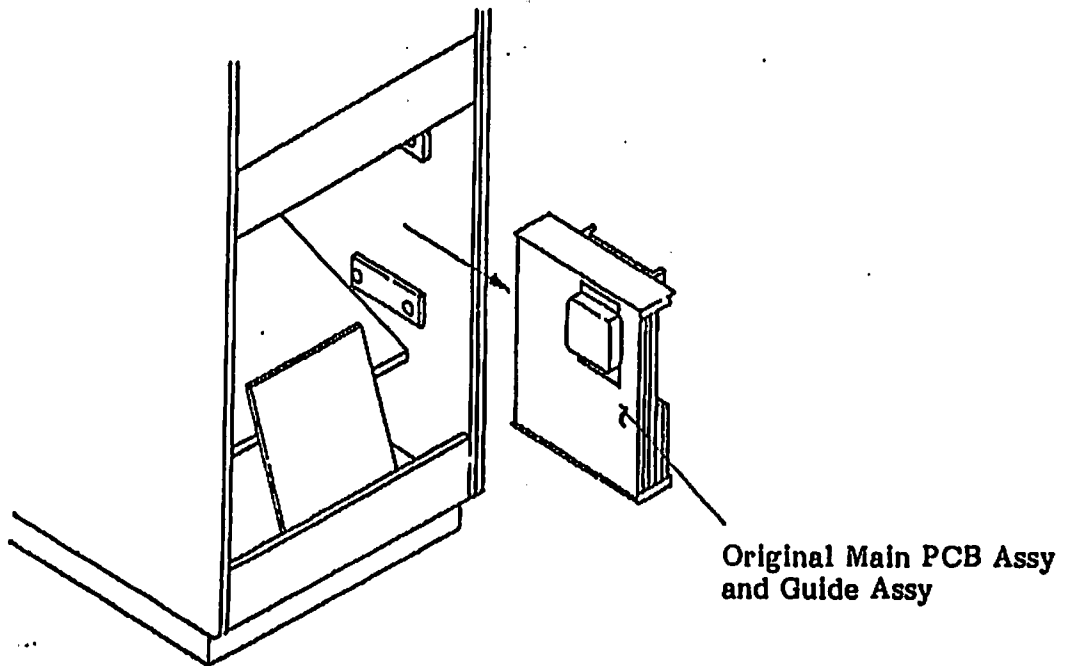

\* Attach the Res. Locks to the Relay PCB Assy by using Screws as shown below.

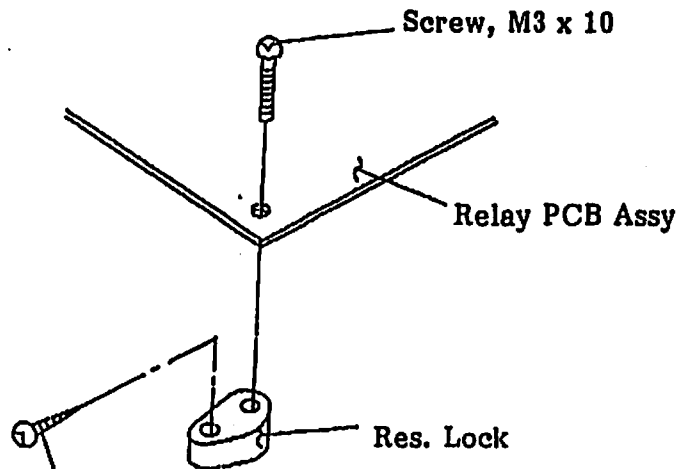

Wood Screw, 3.5 Dia. x 16  
(These Screws are to be used when attaching this part to the Cabinet.)

RELAY BOARD

BEFORE INSTALLATION AND CONNECTION INSURE THAT THERE IS A SHORT JUMPER BETWEEN PINS 1 AND 3 ON THE "F" CONNECTOR. SINCE "BUGGY CHALLENGE" HAS ONLY ONE AUDIO OUTPUT AND TURBO HAS TWO AMPLIFIERS. THIS JUMPER SUPPLIES AUDIO TO BOTH AMPLIFIERS AND ALL SPEAKERS SHOULD OPERATE WITH THE GAME IN PROGRESS.

THREE 470ohms RESISTORS HAVE BEEN ADDED AT CONNECTOR "E" PINS 3, 4 AND 5 TO GROUND TO IMPROVE THE VIDEO.

REMOVE SPACERS FROM CORNERS OF PCB ASSEMBLY AND INSTALL SPACERS AND RES LOCKS AS SHOWN BELOW.

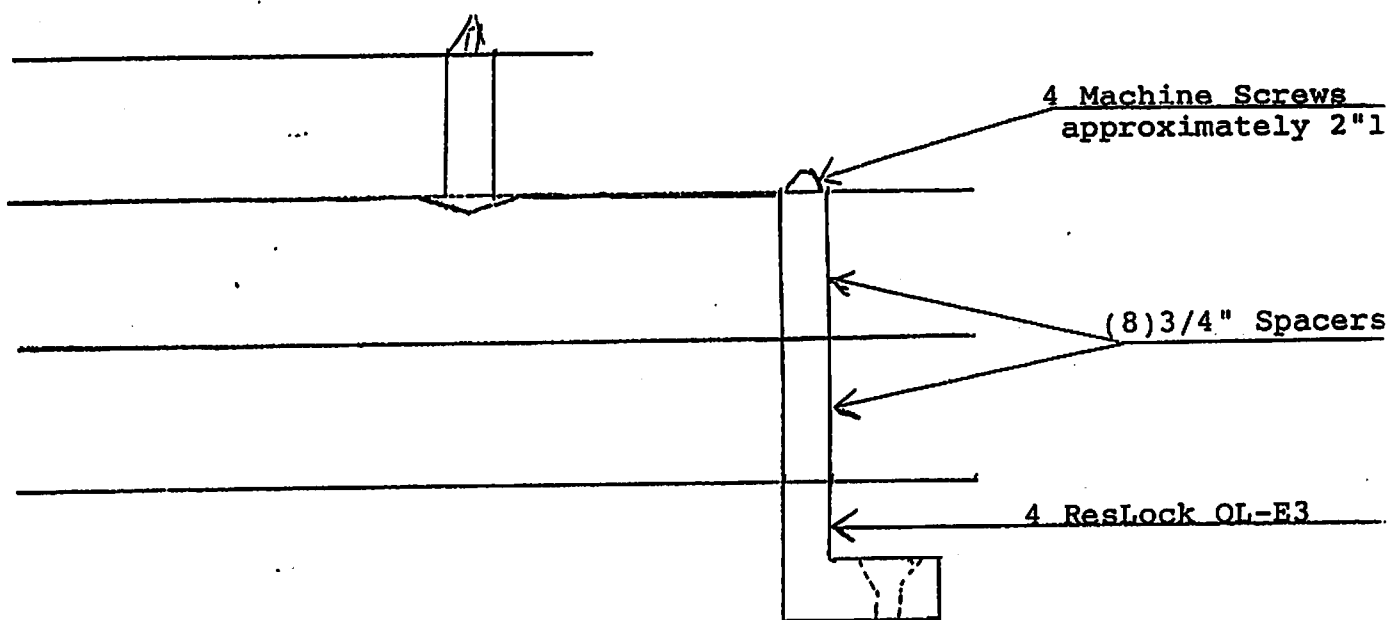

BOARD INSTALLATION

THE RELAY BOARD SHOULD BE MOUNTED JUST ABOVE THE LOWER MOUNTING BLOCK WHICH SUPPORTED THE TURBO BOARDS, AND 2½" FROM THE REAR OF THE CABINET WITH THE CONNECTORS FOR TURBO HARNESS UP. THE WIRE HARNESS WILL BE UNDER THE RELAY BOARD.

\*\*\*\*\*

\*\*\*\*\* CAUTION \*\*\*\*\*

ON CONNECTOR "C" OF TURBO, HARNESS PINS #5 AND #6 WERE BOTH +5VDC. FOR "BUGGY CHALLENGE," PIN #6 HAS BEEN CHANGED TO +12VDC. PIN #6 MUST GO TO THE COIN COUNTER. FAILURE TO INSURE THIS CONDITION WILL RESULT IN INSTANT DAMAGE TO THE PHOTOSENSOR BOARDS ON STEERING AND ACCELERATOR ASSEMBLIES.

\*\*\*\*\*

F.C.C. CAGE & BOARD INSTALLATION

OPEN FCC CAGE AND LAY FLAT WITH THE WHITE SIDE UP. CENTER PCB ASSEMBLY ON SECTION OF FCC CAGE THAT HAS NO HOLES PUNCHED IN IT. MARK POSITION OF MOUNTING HOLES AND PUNCH OUT WITH AWL. FOLD FCC CAGE ON DOTTED LINES TO FORM A BOX.

POSITION "BUGGY CHALLENGE" BOARD AND FCC CAGE IN CABINET, APPROXIMATELY 1" BELOW UPPER MOUNTING BLOCK USED FOR TURBO BOARDS, USING 4, 5/8 x #6 SHEET METAL SCREWS. REPOSITIONING OF HARNESS MAY BE NECESSARY.

CONNECT RELAY HARNESS BETWEEN PCB ASSEMBLY AND RELAY BOARD. (REFER TO PICTURE ON PAGE 9.)

CLOSE FCC CAGE TO ENCLOSE PCB ASSEMBLY.

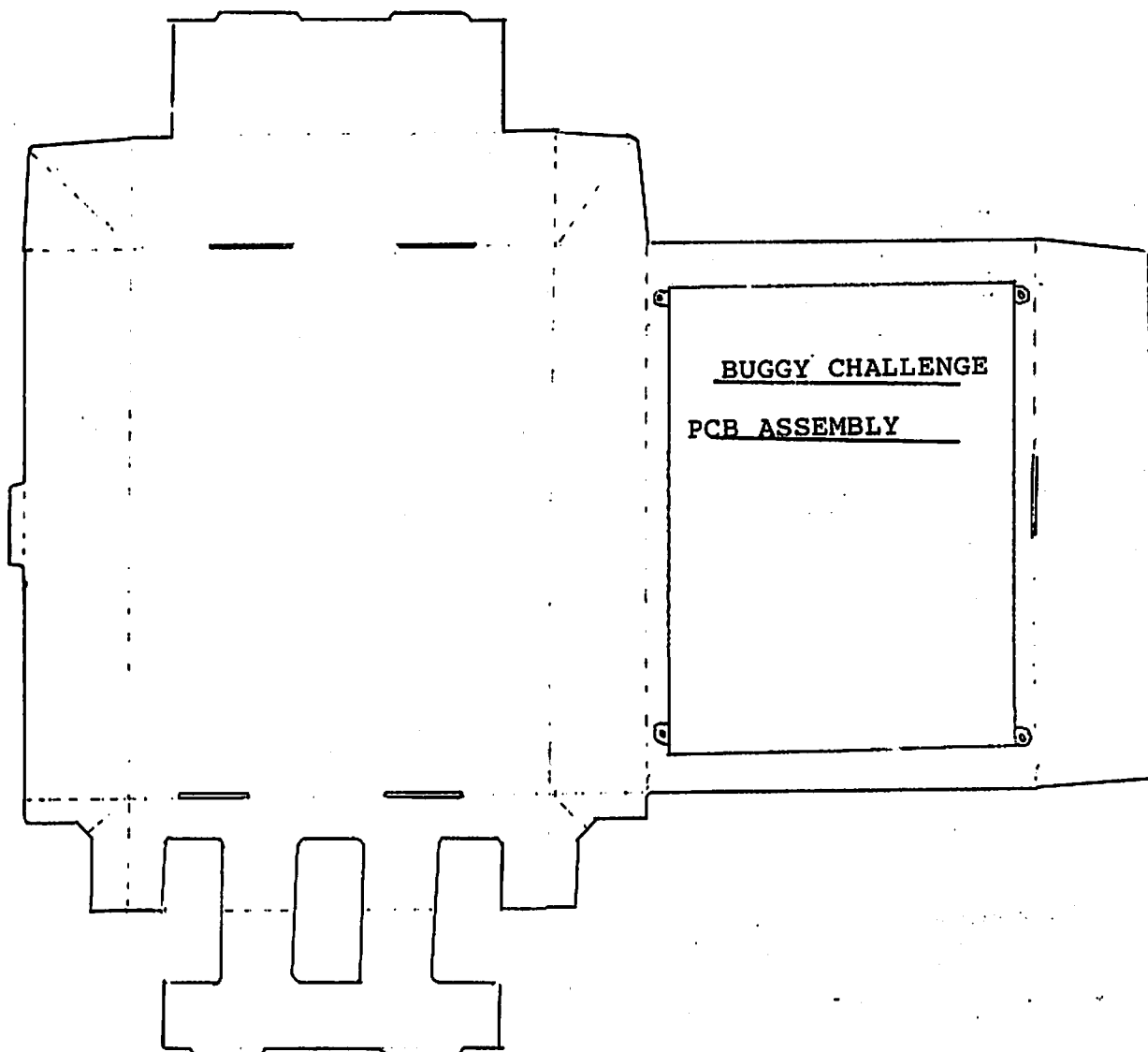

CONNECTING THE HARNESS

IT MAY BE NECESSARY TO LOOSEN THE HARNESS TIES TO ALLOW THE CONNECTORS TO REACH THE PROPER CONNECTORS ON THE RELAY PCB.

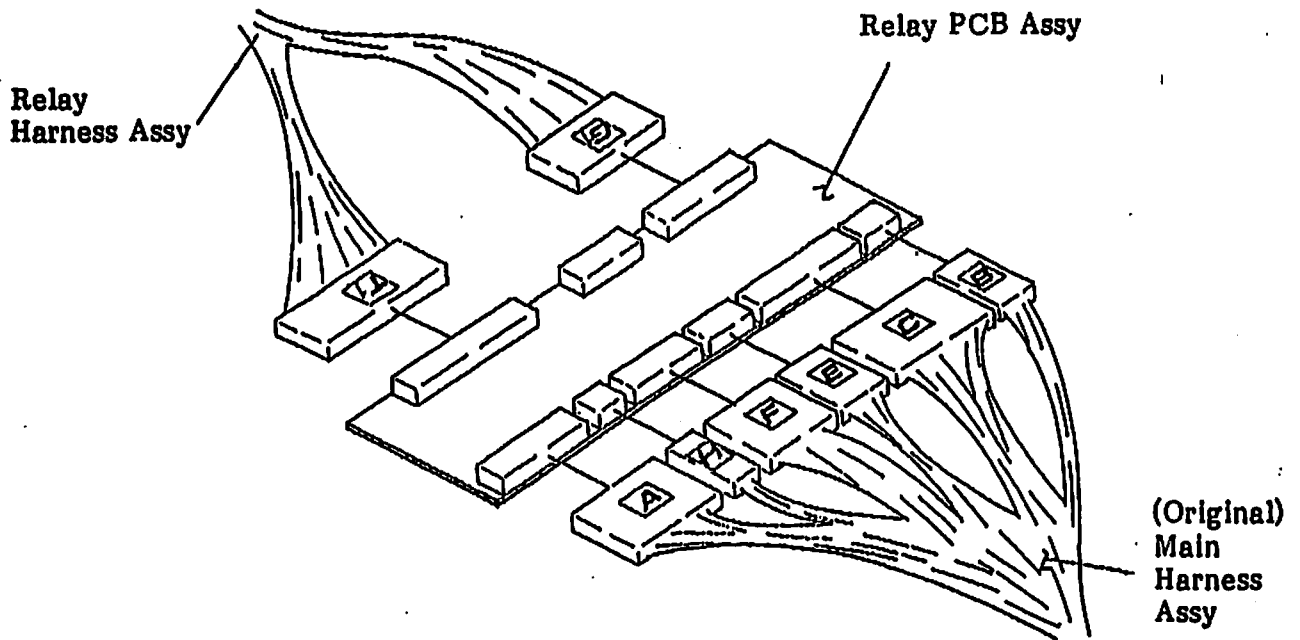

THE RIBBON CABLE TO THE L.E.D. DISPLAY IS NOT USED ON "BUGGY CHALLENGE" AND MAY BE REMOVED OR TIED OUT OF THE WAY.

CONNECT THE RELAY HARNESS BETWEEN THE RELAY BOARD AND THE CONNECTORS ON "BUGGY CHALLENGE" PCB'S AS MARKED.

DRESS THE HARNESS SO THAT NONE OF THE CONNECTORS ON THE RELAY BOARD ARE STRAINED AND TIGHTEN THE WIRE TIES.



THE GAME SHOULD NOW BE READY TO POWER UP AND CHECK OUT.

WITH THE GAME IN PLAY, THE VOLUME CONTROL LOCATED ON THE SOUND BOARD (THE SMALL BOARD ON TOP OF PCB ASSEMBLY) NEXT TO THE AMPLIFIER SHOULD BE ADJUSTED. VERY LITTLE OUTPUT FROM THE BOARD IS NEEDED, AS THE TWO AMPLIFIERS IN TURBO WILL BE QUITE SUFFICIENT.

THE VOLUME CONTROL IS LOCATED ON THE SOUND BOARD (TOP BOARD IN ASSEMBLY) NEXT TO THE RIBBON CABLE CONNECTOR. TURN CONTROL FULLY COUNTER CLOCKWISE, AND THEN CLOCKWISE APPROXIMATELY 1/8th TURN.

If the Coin Meter does not function properly (after the conversion having been made), it is due to the difference of the internal resistance of the Coin Meter. To eliminate this problem, add a couple of resistors (13-20 Ohm 1/2W  $\pm$ 5%) on the CPU Board, as shown below.

CPU PCB Assy (Component Side) of the Main PCB Assy  
for BUGGY CHALLENGE

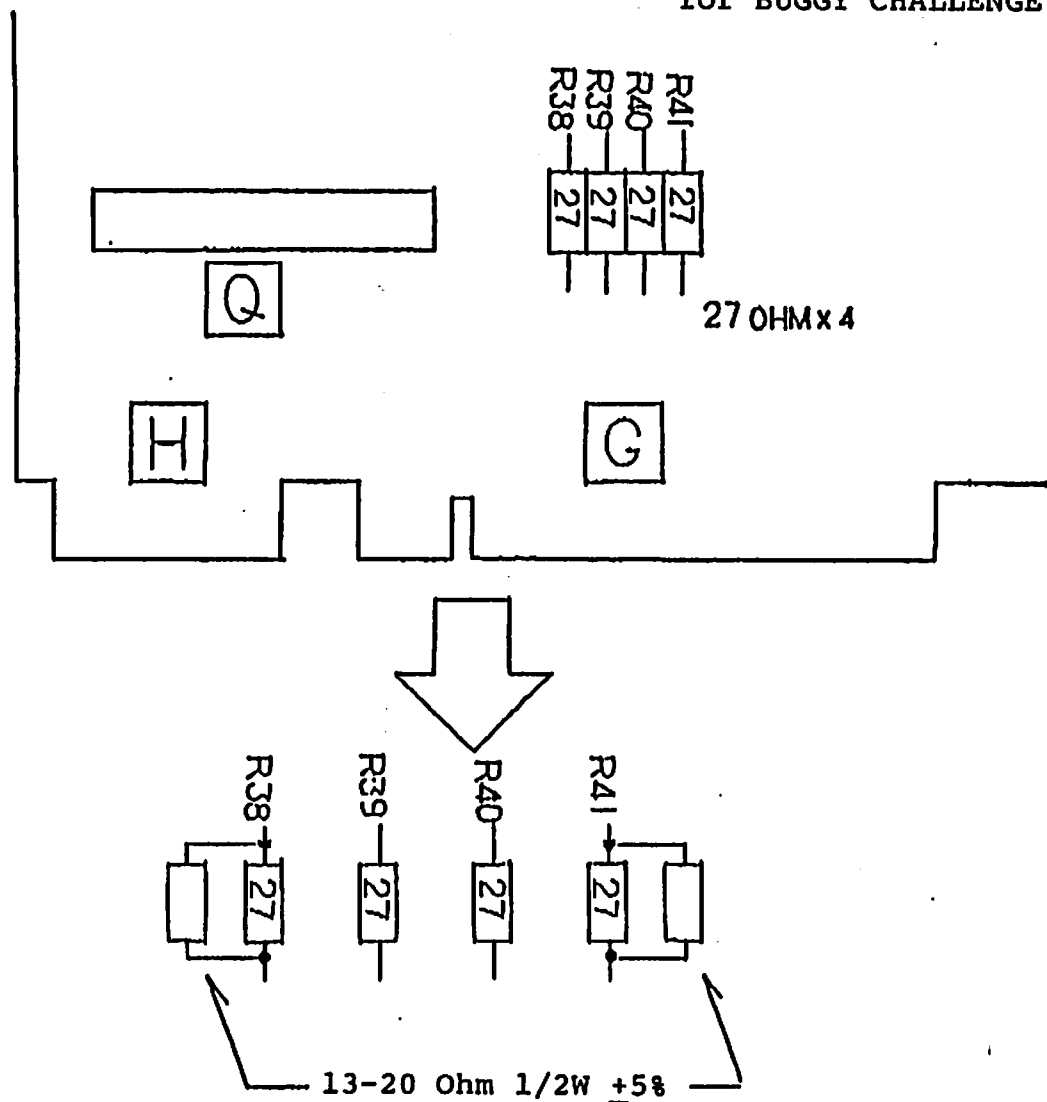

After making the conversion, be sure to do the color adjustment of the TV Monitor.

INSTALL SIDE GRAPHICS

ON THE SIDE OF THE CABINET MEASURE 20" FROM BLACK BORDER AT THE BOTTOM EDGE OF CABINET. MARK AT THE FRONT AND REAR EDGE. PEEL PAPER FROM BACK OF STICKER. ALIGN TOP WITH MARKS AND EDGE WITH BLACK BORDER AT FRONT EDGE OF CABINET. REPEAT FOR THE OPPOSITE SIDE.

